



Hitachi Storage Navigator Modular 2 Advanced Settings User's Guide

FASTFIND LINKS

[Document Organization](#)

[Product Version](#)

[Getting Help](#)

[Contents](#)

Copyright © 2010 Hitachi Ltd., Hitachi Data Systems Corporation, ALL RIGHTS RESERVED

Notice: No part of this publication may be reproduced or transmitted in any form or by any means, electronic or mechanical, including photocopying and recording, or stored in a database or retrieval system for any purpose without the express written permission of Hitachi Ltd., and Hitachi Data Systems Corporation (hereinafter referred to as "Hitachi Data Systems").

Hitachi Ltd. and Hitachi Data Systems reserve the right to make changes to this document at any time without notice and assume no responsibility for its use. Hitachi Ltd. and Hitachi Data Systems products and services can only be ordered under the terms and conditions of Hitachi Data Systems' applicable agreements.

All of the features described in this document may not be currently available. Refer to the most recent product announcement or contact your local Hitachi Data Systems sales office for information on feature and product availability.

This document contains the most current information available at the time of publication. When new and/or revised information becomes available, this entire document will be updated and distributed to all registered users.

Hitachi is a registered trademark of Hitachi, Ltd. in the United States and other countries. Hitachi Data Systems is a registered trademark and service mark of Hitachi, Ltd. in the United States and other countries.

IBM is a registered trademark of International Business Machines.

All other brand or product names are or may be trademarks or service marks of and are used to identify products or services of their respective owners.



Contents

Preface	ix
Intended audience	X
Product version	X
Release notes and readme	X
Document revision level	X
Changes in this revision	X
Document organization	xi
Convention in syntax explanations	xii
Accessing product documentation	xiv
Getting Help	xx
Comments	xxi
Overview	1-1
Notes on Using Hitachi Storage Navigator Modular 2	1-2
Environment	1-8
Windows	1-8
Red Hat Linux	1-10
Solaris	1-10
Common Environment	1-12
IPv6 Supported Platforms	1-13
Connecting Hitachi Storage Navigator Modular 2 to the Host	1-14
Installing Hitachi Storage Navigator Modular 2	1-15
Preparation	1-15
Setting of Linux Kernel Parameters	1-18
Setting of Solaris 8 or Solaris 9 Kernel Parameters	1-20
Setting of Solaris 10 Kernel Parameters	1-20
Installing	1-22
Updating	1-29
Uninstalling	1-33

Getting Started	2-1
Functional Overview	2-2
Launching the Application	3-1
Starting	3-2
Host side.....	3-2
Client side	3-2
Operations	3-5
Help3-10	
Changing the Port Number and Connection Address	3-12
Changing the Port Number for Starting Navigator 2	3-12
Changing the Port Number for Applet Screen of Navigator 2.....	3-13
Changing the Connection Address for Applet Screen of Navigator 2.....	3-14
Stopping and Starting the Services (Daemon Process)	3-15
Stopping the Services (Daemon Process)	3-16
Stopping the SNM2 Server Service (Daemon Process)	3-16
Stopping the Hitachi Storage Command Suite Common Components.....	3-17
Starting the Services (Daemon Process).....	3-18
Starting the Command Suite Common Components	3-19
Starting the SNM2 Server Service (Daemon Process)	3-20
Automatic Log-off.....	3-21
Setting the Server Certificate and Private Key	3-22
Setting the Server Certificate and Private Key for Applet Screen of Navigator 2....	3-25
Advanced Settings.....	4-1
Starting the Advanced Settings.....	4-2
Configuration Settings.....	4-4
Boot Options	4-4
System Parameter.....	4-7
Port Options	4-10
Restore Options.....	4-12
Online Verify	4-15
Constitute	4-16
File Output for System Parameters.....	4-17
Setting System Parameters with a File.....	4-19
RAID Groups/Logical Units and Configuration File Output Status	4-20
Setting RAID Group/Logical Unit Definition with a File	4-22
Port Information File Output.....	4-26
Setting Port Information with a File.....	4-30
File Output of Boot Option Information	4-32
Setting Boot Option Information with a File	4-34
File Output of Parts Information	4-37

Setting CHAP User Information with a File.....	4-39
File Output of LAN Information.....	4-41
Setting LAN Information with a File	4-44
Ping.....	4-47
Format Mode.....	4-49
Access Mode.....	4-51
Mapping Guard	4-53
Parity Correction	4-55

Hitachi Storage Navigator Modular 2 on 9500VIAMS/WMS Arrays 5-1

Definition of RAID Group/Logical Unit	5-13
Displaying RAID Group/Logical Unit Definition.....	5-13
Creating a RAID Group Automatically	5-14
Creating a RAID Group Manually	5-16
Deleting a Specified RAID Group.....	5-18
Constituting a Logical Unit Automatically	5-19
Constituting a Logical Unit Manually	5-23
Formatting a Logical Unit	5-25
Deleting a Specified Logical Unit	5-27
Changing Default Controller in Charge of a Logical Unit	5-28
Parity Correction.....	5-29
Configuring Array Unit.....	5-32
Creating Logical Units by Wizard	5-32
Designating Spare Drives	5-34
Designating Spare Drives.....	5-34
Releasing Spare Drive.....	5-37
Setting Differential Management LU	5-37
Setting Differential Management LU.....	5-38
Releasing Differential Management LU.....	5-39
Setting Command Devices.....	5-40
Setting Command Devices	5-40
Changing Command Devices.....	5-43
Releasing Command Devices.....	5-44
Setting Optional Features	5-44
Installing Optional Features	5-45
De-installing Optional Features.....	5-47
Setting Optional Features	5-47
Setting Host Group Information.....	5-49
Setting Host Group Options	5-49
Setting Mapping Guard.....	5-52
Specifying Mapping Mode.....	5-53
Setting Mapping Information.....	5-54
Setting Target Information.....	5-57

Setting Target Options	5-57
Setting Mapping Guard.....	5-60
Specifying Mapping Mode	5-61
Setting Mapping Information	5-62
CHAP User	5-65
Adding a CHAP User	5-65
Changing the CHAP User.....	5-66
Deleting the CHAP User	5-68
Setting a Target Information.....	5-68
Changing Target Information	5-68
Initializing the Target 000	5-70
Setting System Parameters	5-71
Setting Boot Options	5-71
Setting Fibre Channel Information	5-73
Displaying Fibre Channel Information.....	5-73
Setting Fibre Channel Settings.....	5-74
Setting iSCSI Port Information	5-75
Setting iSNS Server Information	5-75
Sending Ping	5-76
Setting System Parameters.....	5-77
Setting Port Options.....	5-80
Setting Drive Restoration Options.....	5-81
Online Verify Mode.....	5-82
Setting Format Priority Mode.....	5-83
Setting LAN Configuration.....	5-84
Setting LAN Configuration without Rebooting.....	5-84
Setting LAN Configuration with Rebooting	5-86
Setting the LAN Port Number	5-88
Setting the IP Address of the Maintenance Port	5-90
Setting RTC.....	5-91
Setting Time Zone and NTP Server	5-92
Outputting Configuration Information to a File.....	5-93
File Output for System Parameters.....	5-94
Setting System Parameters with a File.....	5-95
RAID/Logical Units and Configuration File Output Status.....	5-96
Setting RAID Group/Logical Unit Definition with a File	5-98
Port/Host Group Information File Output	5-100
Setting Port/Host Group Information with a File	5-101
File Output of Boot Option Information	5-102
Setting Boot Option Information with a File	5-104
File Output of Parts Information	5-105
Outputting NAS System LU/User LU to a File	5-106
Setting NAS System LU/User LU Information with a File.....	5-107
File Output of iSCSI Port Information	5-107

Setting iSCSI Port Information with a File.....	5-110
Setting CHAP User Information with a File.....	5-111
File Output of LAN Information.....	5-112
Setting LAN Information with a File	5-114
Replacing a Firmware.....	5-115
Firmware Download	5-116
Replacing a Firmware	5-119
Setting the Backend Diagnosis Information	5-121
Configuring NNC	5-123
Setting NNC LAN Information	5-123
Setting NAS System Logical Units.....	5-124
For NNC Type2	5-125
For NNC Type1	5-127
Setting NAS User Logical Units.....	5-128
Shutting Down/Booting/Rebooting NNC.....	5-130
Shutting Down the NNC.....	5-130
Booting the NNC	5-132
Rebooting the NNC.....	5-132
Displaying Statistical Information.....	5-134
Displaying Controller Activity	5-134
Displaying Host Commands Received (Read/Writes per LU).....	5-135
Displaying Command Execution Activity	5-135
Displaying Cache Load Condition.....	5-136
Acquiring Performance Information.....	5-138
Collecting Performance Statistics.....	5-138
Manually Outputting Performance Statistics to a Text File	5-138
Automatically Outputting Performance Statistics to a Text File.....	5-146
Tuning Parameters	5-149
Multi Stream Tuning Parameters	5-149
Prefetch Parameters	5-151
Setting System Tuning Parameters.....	5-153
ACE Tool	5-155
Automatic Setting	5-155
Cable Figure Detail	5-158

Collecting Navigator 2 Diagnostic Information.....	A-1
Performance Output Text File Information.....	B-1
Acronyms and Abbreviations	
Glossary	
Index	



Preface

This document describes and provides instructions for using the Hitachi Navigator 2 Advanced Settings.

Please read this document carefully to understand how to use this product, and maintain a copy for reference purposes.

This preface includes the following information:

- [Document revision level](#)
- [Changes in this revision](#)
- [Intended audience](#)
- [Document organization](#)
- [Product version](#)
- [Release notes](#)
- [Conventions in syntax explanations](#)
- [Related documents](#)
- [Regulatory information](#)
- [Getting help](#)
- [Support contact information](#)
- [HDS support website](#)
- [Interoperability information](#)
- [Comments](#)

Intended audience

This document is intended for personnel who will schedule, manage, and perform the tasks required to prepare your site for installing a Hitachi AMS 2000 Family storage system.

Product version

This document applies to Hitachi AMS 2000 Family firmware version 0890/A or later.

Release notes and readme

Read the release notes and readme file before installing and using this product. They may contain requirements or restrictions that are not fully described in this document and/or updates or corrections to this document.

Document revision level

Revision	Date	Description
MK-97DF8039-00	May 2009	Initial Release
MK-97DF8039-01	June 2009	Revision 1, supersedes and replaces MK97DF8039-00
MK-97DF8039-02	August 2009	Revision 2, supersedes and replaces MK97DF8039-01
MK-97DF8039-03	November 2009	Revision 3, supersedes and replaces MK97DF8039-02
MK-97DF8039-04	December 2009	Revision 4, supersedes and replaces MK97DF8039-03
MK-97DF8039-05	January 2010	Revision 5, supersedes and replaces MK97DF8039-04
MK-97DF8039-06	April 2010	Revision 6, supersedes and replaces MK97DF8039-05

Changes in this revision

- New firmware information for environments on page 1-8.
- Supported virtual operating systems provided in Virtual OS table on page 1-8
- Operating environments of guest OS provided on page 1-8.
- Specifications for the operating environments of Hitachi Storage Navigator Modular 2 on page 1-9.

- New Red Hat Enterprise Linux 5.3 version specified for the host on page 1-10.
- New Red Hat Enterprise Linux 5.3 version specified for the client on page 1-10.
- New Red Hat Enterprise Linux 5.3 version specified for IPv6 supported platforms on page 1-13.
- Provide new Arrays and SMS100 Arrays screens figure on page 3-5.
- Provide new output for Format Outline of Port Information on page 4-28.

Document organization

Thumbnail descriptions of the chapters are provided in the following table. Click the chapter title in the first column to go to that chapter. The first page of every chapter or appendix contains links to the contents.

Chapter		Description
1	Overview	This chapter provides information on installing Navigator 2 under different platforms, including installing, updating, and removing.
2	Getting Started	This chapter provides a functional overview of Navigator 2.
3	Launching the Application	This chapter details the launch process on the Host and Client side, port number information, and SSL information.
4	Advanced Settings	This chapter provides details on how to start advanced settings java applet and access the available functions.
5	Hitachi SNM2 9500 VIAMS WMS Arrays	This chapter provides information on how to use Navigator 2 to view and manage legacy Hitachi storage systems.
A	Collecting Navigator2 Diagnostic Information	This appendix provides details on how to obtain Navigator 2 diagnostic information.
B	Performance Output Text File Info	This appendix provides details of the performance output text file.



Convention in syntax explanations

The following table lists the conventions used in syntax explanations.

Example symbol	Convention
	Only one of the options separated by a vertical bar can be used at one time. Example: A B C This indicates A, or B, or C.
[]	The item or items enclosed in brackets are optional. Example 1: [A] This indicates the specification of A or nothing. When multiple items are delimited by the vertical bar and enclosed in the brackets, it indicates that all are omitted or any one is selected. Example 2: [B C] This indicates the specification of B or C, or nothing. However, when all the items are enclosed in the brackets, it may be necessary to specify one or more items. Example 3: [A] [B] This indicates the specification of A, B, or both A and B, or nothing.
...	The item or items preceding the ellipsis (...) can be repeated. To specify multiple items, use a space to delimit them. Example: A, B ... This indicates that B can be specified as many times as necessary after A.



Safety and warnings

This document uses the following symbols to draw attention to information:

Icon	Label	Description
	Note	Calls attention to important and/or additional information.
	Caution	Warns the user of adverse conditions and/or consequences (e.g., disruptive operations).

Document conventions

This document uses the following symbols to draw attention to important safety and operational information.

Symbol	Meaning	Description
	Tip	Tips provide helpful information, guidelines, or suggestions for performing tasks more effectively
	Note	Notes emphasize or supplement important points of the main text.
	Caution	Cautions indicate that failure to take a specified action could result in damage to the software or hardware.

This document uses the following typographic conventions:

Typographic Convention	Description
Bold	Indicates text on a window, other than the window title, including menus, menu options, buttons, fields, and labels. Example: Click OK .
<i>Italic</i>	Indicates a variable, which is a placeholder for actual text provided by the user or system. Example: <i>copy source-file target-file</i> Note: Angled brackets (< >) are also used to indicate variables.
screen/code	Indicates text that is displayed on screen or entered by the user. Example: # pairdisplay -g oradb
< > angled brackets	Indicates a variable, which is a placeholder for actual text provided by the user or system. Example: # pairdisplay -g <group> Note: Italic font is also used to indicate variables.
[] square brackets	Indicates optional values. Example: [a b] indicates that you can choose a, b, or nothing.
{ } braces	Indicates required or expected values. Example: { a b } indicates that you must choose either a or b.
vertical bar	Indicates that you have a choice between two or more options or arguments. Examples: [a b] indicates that you can choose a, b, or nothing. { a b } indicates that you must choose either a or b.
<u>underline</u>	Indicates the default value. Example: [<u>a</u> b]

Convention for storage capacity values

Storage capacity values (e.g., disk drive capacity) are calculated based on the following values:

Physical capacity unit	Value
1 KB	1,000 bytes
1 MB	1,000 KB or 1,000 ² bytes
1 GB	1,000 MB or 1,000 ³ bytes
1 TB	1,000 MB or 1,000 ⁴ bytes
1 PB	1,000 TB or 1,000 ⁵ bytes
1 EB	1,000 PB or 1,000 ⁶ bytes

Logical storage capacity values (for example, logical device capacity) are calculated based on the following values:

Physical capacity unit	Value
1 KB	1,000 bytes
1 MB	1,024 KB or 1,024 ² bytes
1 GB	1,024 MB or 1,024 ³ bytes
1 TB	1,024 MB or 1,024 ⁴ bytes
1 PB	1,024 TB or 1,024 ⁵ bytes
1 EB	1,024 PB or 1,024 ⁶ bytes

Accessing product documentation

The AMS 2000 Family user documentation is available on the Hitachi Data Systems Portal: <https://portal.hds.com>. Please check this site for the most current documentation, including important updates that may have been made after the release of the product.

This documentation set consists of the following documents.

Release notes

- Hitachi Adaptable Modular Storage System Release Notes (RN-AMS100)
- Hitachi Storage Navigator Modular 2 Release Notes (RN-SNM2)



Note: Please read the Release Notes before installing and/or using this product. They may contain requirements and/or restrictions not fully described in this document, along with updates and/or corrections to this document.

Installation and getting started

The following documents provide instructions for installing an AMS 2100, AMS 2000 Family storage system. They include rack information, safety information, site-preparation instructions, getting-started guides for experienced users, and host connectivity information.

- **Hitachi AMS 2000 Family Site Preparation Guide**, MK-98DF8149
Contains site planning and pre-installation information for AMS 2000 Family storage systems, expansion units, and high-density expansion units. This document also covers safety precautions, rack information, and product specifications.
- **Hitachi AMS2100/2300 Getting Started Guide**, MK-98DF8152
Provides quick-start instructions for getting an AMS 2100/2300 storage system up and running as quickly as possible.
- **Hitachi AMS2500 Getting Started Guide**, MK-97DF8032
Provides quick-start instructions for getting an AMS 2500 storage system up and running as quickly as possible.
- **Hitachi AMS 2000 Family Fibre Channel Host Installation Guide**, MK-08DF8189
Describes how to configure host operating systems for use with an AMS 2000 Family fibre channel storage system.
- **Hitachi AMS 2000 Family iSCSI Host Installation Guide**, MK-08DF8188
Describes how to configure host operating systems for use with an AMS 2000 Family iSCSI storage system.

Configuration and storage features

The following documents describe how to configure AMS 2000 Family storage systems, and use Storage Navigator Modular 2 (Navigator 2) to perform storage and replication activities.

- **Hitachi Storage Navigator 2 Advanced Settings User's Guide**, MK-97DF8039 – this manual
Contains advanced information about launching and using Navigator 2 in various operating systems, IP addresses and port numbers, server certificates and private keys, boot and restore options, outputting configuration information to a file, and collecting diagnostic information.
- **Hitachi Storage Navigator Modular 2 User's Guide**, MK-99DF8208
Describes how to use Navigator 2 to configure and manage storage on an AMS 2000 Family storage system.
- **Hitachi AMS 2000 Family Dynamic Provisioning Configuration Guide**, MK-09DF8201
Describes how to use virtual storage capabilities to simplify storage additions and administration.
- **Hitachi Storage Navigator 2 Storage Features Reference Guide for AMS**, MK-97DF8148
Contains concepts, preparation, and specifications for Account Authentication, Audit Logging, Cache Partition Manager, Cache Residency Manager, Data Retention Utility, LUN Manager, Performance Monitor, SNMP Agent, and Modular Volume Migration.
- **Hitachi AMS 2000 Family Copy-on-write SnapShot User's Guide**, MK-97DF8124
Describes how to create point-in-time copies of data volumes in AMS 2100/2300/2500 storage systems, without impacting host service and performance levels. Snapshot copies are fully read/write compatible with other hosts and can be used for rapid data restores, application testing and development, data mining and warehousing, and nondisruptive backup and maintenance procedures.

- **Hitachi AMS 2000 Family ShadowImage In-system Replication User's Guide**, MK-97DF8129

Describes how to perform high-speed nondisruptive local mirroring to create a copy of mission-critical data in AMS 2100/2300/2500i storage systems. ShadowImage keeps data RAID-protected and fully recoverable, without affecting service or performance levels. Replicated data volumes can be split from host applications and used for system backups, application testing, and data mining applications while business continues to operate at full capacity.

- **Hitachi AMS 2000 Family TrueCopy Remote Replication User's Guide**, MK-97DF8052

Describes how to create and maintain multiple duplicate copies of user data across multiple AMS 2000 Family storage systems to enhance your disaster recovery strategy.

- **Hitachi AMS 2000 Family TrueCopy Extended Distance User's Guide**, MK-97DF8054

Describes how to perform bi-directional remote data protection that copies data over any distance without interrupting applications, and provides failover and recovery capabilities.

- **Hitachi AMS 2000 Data Retention Utility User's Guide**, MK-97DF8019

Describes how to lock disk volumes as read-only for a certain period of time to ensure authorized-only access and facilitate immutable, tamper-proof record retention for storage-compliant environments. After data is written, it can be retrieved and read only by authorized applications or users, and cannot be changed or deleted during the specified retention period.

- **Hitachi Storage Navigator Modular 2 online help**

Provides topic and context-sensitive help information accessed through the Navigator 2 software.

Hardware maintenance and operation

The following documents describe how to operate, maintain, and administer an AMS 2000 Family storage system. They also provide a wide range of technical information and specifications for the AMS 2000 Family storage systems.

- **Hitachi AMS 2100/2300 Storage System Hardware Guide**, MK-97DF8010
Provides detailed information about installing, configuring, and maintaining an AMS 2100/2300 storage system.
- **Hitachi AMS 2500 Storage System Hardware Guide**, MK-97DF8007
Provides detailed information about installing, configuring, and maintaining an AMS 2500 storage system.
- **Hitachi AMS 2000 Family Storage System Service and Upgrade Guide**, MK-97DF8009
Provides information about servicing and upgrading AMS 2100/2300/2500 storage systems.
- **Hitachi AMS 2000 Family Power Savings Guide**, MK-97DF8045
Describes how to spin down volumes in selected RAID groups when they are not being accessed by business applications to decrease energy consumption and significantly reduce the cost of storing and delivering information.
- **Hitachi AMS 2000 Family Technical Reference Specifications**, MK-97DF8008
Contains specifications and technical information about power cables, system parameters, interfaces, logical blocks, RAID levels and configurations, and regulatory information about AMS 2100/2300/2500 storage systems. This document also contains remote adapter specifications and regulatory information.

Command and Control (CCI)

The following documents describe how to install the Hitachi AMS 2000 Family Command Control Interface (CCI) and use it to perform TrueCopy and ShadowImage operations.

- **Hitachi AMS 2000 Family Command Control Interface (CCI) Installation Guide**, MK-97DF8122

Describes how to install CCI software on open-system hosts.

- **Hitachi AMS 2000 Family Command Control Interface (CCI) Reference Guide**, MK-97DF8121

Contains reference, troubleshooting, and maintenance information related to CCI operations on AMS 2100/2300/2500 storage systems.

- **Hitachi AMS 2000 Family Command Control Interface (CCI) User's Guide**, MK-97DF8123

Describes how to use CCI to perform TrueCopy and ShadowImage operations on AMS 2100/2300/2500 storage systems.

Command Line Interface (CLI)

The following documents describe how to use Hitachi Storage Navigator Modular 2 to perform management and replication activities from a command line.

- **Hitachi Storage Navigator Modular 2 Command Line Interface (CLI) Unified Reference Guide**, MK-97DF8089

Describes how to interact with all Navigator 2 bundled and optional software modules by typing commands at a command line.

- **Hitachi Storage Navigator 2 Command Line Interface Replication Reference Guide for AMS**, MK-97DF8153

Describes how to interact with Navigator 2 to perform replication activities by typing commands at a command line.

Hitachi Dynamic Replicator Documentation

The following documents describe how to install, configure, and use Hitachi Dynamic Replicator to provide AMS Family storage systems with continuous data protection, remote replication, and application failover in a single, easy-to-deploy and manage platform.

- **Hitachi Dynamic Replicator Release Notes – Scout Release Notes**, RN-99DF8211

- **Hitachi Dynamic Replicator Administration Guide**, MK-97DF8212
- **Hitachi Dynamic Replicator Installation and Configuration Guide**, MK-97DF8213
- **Hitachi Dynamic Replicator Quick Start Guide**, MK-97DF8214
- **Hitachi Dynamic Replicator Troubleshooting Guide**, MK-97DF8215
- **Hitachi Dynamic Replicator Utility Guide**, MK-97DF8216
- **Hitachi Dynamic Replicator RX Server Deployment Guide**, MK-97DF8217
- **Hitachi Dynamic Replicator VX Solution for Oracle (Solaris)**, MK-97DF8218
- **Hitachi Dynamic Replicator Solution for SharePoint 2007**, MK-97DF8219
- **Hitachi Dynamic Replicator Solution for My SQL (Windows)**, MK-97DF8220
- **Protecting Citrix XenServer Using Hitachi Dynamic Replicator**, MK-97DF8221
- **Hitachi Dynamic Replicator Quick Install/Upgrade Guide**, MK-97DF8222
- **Hitachi Dynamic Replicator - Protecting MS SQL Server**, MK-97DF8223
- **Hitachi Dynamic Replicator - Protecting MS Exchange Server**, MK-97DF8224
- **Hitachi Dynamic Replicator File Server Solution**, MK-97DF8225

Getting Help

If you need to contact the Hitachi Data Systems support center, please provide as much information about the problem as possible, including:

- The circumstances surrounding the error or failure.
- The exact content of any messages displayed on the host system(s).
- The exact content of any messages displayed on Storage Navigator Modular 2.
- The Storage Navigator Modular 2 configuration information. This information is used by service personnel for troubleshooting purposes.

The Hitachi Data Systems customer support staff is available 24 hours a day, seven days a week. If you need technical support, please log on to the Hitachi Data Systems Portal for contact information:

<https://portal.hds.com>.

Comments

Please send us your comments on this document: doc.comments@hds.com. Include the document title, number, and revision, and refer to specific section(s) and paragraph(s) whenever possible.

Thank you! (All comments become the property of Hitachi Data Systems)

Overview

This chapter provides important notes regarding the installation environment and OS platform support.

This chapter includes the following:

- Notes on Using Hitachi Storage Navigator Modular 2
- Environment
- Connecting Hitachi Storage Navigator Modular 2 to the Host
- Installing Hitachi Storage Navigator Modular 2

Notes on Using Hitachi Storage Navigator Modular 2

When using Hitachi Storage Navigator Modular 2, consider the following:

- All of the output files from Applet screens of Hitachi Storage Navigator Modular 2 are sent to the host side. Specify all of the files that Applet screens of Hitachi Storage Navigator Modular 2 inputs Hitachi Storage Navigator Modular 2 activates as files on the host side.
- Hitachi Storage Navigator Modular 2 functions of cannot be used unless a TCP/IP communication is made between the array unit and the host. Verify that the TCP/IP is set correctly.
- Some Hitachi Storage Navigator Modular 2 functions are not available while the array unit is online with a host.
- When a high I/O load exists, the functions that are available while online might cause a command time-out in the host or a recovering fault in Hitachi Storage Navigator Modular 2. It is recommends that these functions be executed while offline.
- When Hitachi Storage Navigator Modular 2 is installed in the host connected to an array unit, I/O loading from a host might cause a command time-out on the host side or an abnormal termination on Hitachi Storage Navigator Modular 2 side.
- Installing Hitachi Storage Navigator Modular 2 in a host that does not connect an array unit is recommended.
- When the host enters the suspension status (low power mode) while Hitachi Storage Navigator Modular 2 is running, Hitachi Storage Navigator Modular 2 might not operate correctly after the host is released from the suspension status.
- When you operate Hitachi Storage Navigator Modular 2, disable power management through Windows® so that the host will not enter the suspension status.
- Hitachi Storage Navigator Modular 2 allows Array unit screens to open for one array unit. When performing operations by opening Array unit screens for one array unit, operations may terminate abnormally. Open only one Array unit screen for one array unit to operate an array unit.
- If Hitachi Storage Navigator Modular 2 does not succeed in connecting to the array unit, the following message may display:

```
An invalid response was received from the subsystem
```

This message indicates that Hitachi Storage Navigator Modular 2 may have been connected to the array unit while the array unit automatically rebooted. Reconnect to the array unit after 3 minutes.
- Hitachi Storage Navigator Modular 2 may hang up in the following cases:

- The communication with the connected array unit fails due to controller blockage, array unit failure, disconnected LAN connection, or the array unit receives a Reset/LIP from the host.
- Other applications are working concurrently and memory utilization or a CPU use rate is high.
- Disconnecting LAN connection of the host and client sides.

If Hitachi Storage Navigator Modular 2 hangs up, check the array unit status and the connection status of the LAN, terminate Hitachi Storage Navigator Modular 2, and restart Hitachi Storage Navigator Modular 2. When not recovered, stop the **SNM2 Server** service (daemon process), check the array unit status and the connection status of the LAN, restart the **SNM2 Server** service (daemon process).

- In the following case, display time of Hitachi Storage Navigator Modular 2 may be longer while operating Hitachi Storage Navigator Modular 2.
 - The communication with the connected array unit fails
 - Failures of the array unit (controller blockade, etc.)

If display time gets longer in Hitachi Storage Navigator Modular 2, check the status of the array unit and the connection status of the LAN, terminate Hitachi Storage Navigator Modular 2, and restart Hitachi Storage Navigator Modular 2. If the array unit has a failure, operate by registering the array unit as the controller of one side. If the controller is blocked, you cannot connect to Hitachi Storage Navigator Modular 2. Operate it by registering the normal controller side until the controller blockade is recovered.

- The Java™ Applet Window may be displayed at the bottom of a screen item (such as a dialog box, popup menu, combo box) on a Hitachi Storage Navigator Modular 2 panel on versions before 6.0. This is not an error.
- When Hitachi Storage Navigator Modular 2 connects the array unit over a LAN, it uses the TCP/IP port number of 2000. The TCP/IP port number of the array unit is set as 2000 by default.
- The restrictions listed in Table 1.1 exist if Hitachi Storage Navigator Modular 2 is used in combination with other programs, for one array unit:

Table 1.1 Restrictions for Multiple Programs used Concurrently for One Array Unit

Program Name	Concurrent Use Supported	Concurrent Use Not Supported
Hitachi Storage Navigator Modular 2	<ul style="list-style-type: none"> ▪ SNMP Function ▪ Disk Array -built-in Web Server Function 	<ul style="list-style-type: none"> ▪ Hitachi Storage Navigator Modular 2 ▪ Storage Navigator Modular for Web
Storage Navigator Modular for Web	<ul style="list-style-type: none"> ▪ SNMP Function ▪ Disk Array -built-in Web Server Function 	<ul style="list-style-type: none"> ▪ Hitachi Storage Navigator Modular 2 ▪ Storage Navigator Modular for Web
SNMP Function	<ul style="list-style-type: none"> ▪ Hitachi Storage Navigator Modular 2 ▪ Storage Navigator Modular for Web ▪ SNMP Function ▪ Disk Array -built-in Web Server Function 	N/A
Disk Array -built-in Web Server Function	<ul style="list-style-type: none"> ▪ Hitachi Storage Navigator Modular 2 ▪ Storage Navigator Modular for Web ▪ SNMP Function ▪ Disk Array -built-in Web Server Function 	N/A



Note: You can have two concurrent instances of Hitachi Storage Navigator Modular 2, provided that they are not connected to the same array system. If one instance terminates forcibly, that may affect the other instance.

Additionally, if one Hitachi Storage Navigator Modular 2 terminates forcibly while using two Hitachi Storage Navigator Modular 2 products simultaneously, another Hitachi Storage Navigator Modular 2 may terminate abnormally. If this occurs, operate Hitachi Storage Navigator Modular 2 that has abnormally terminated again.

If you run a combination of programs in which concurrent use is not allowed, when a program with a usage restriction placed on it has been started, start another program with that combination after terminating the running program.

To operate other programs, refer to their respective user's guides, which are provided with the program products.

It is necessary to change a port number to specify in Hitachi Storage Navigator Modular 2 installation to install it in the host same as Storage Navigator Modular (for Web). Storage Navigator Modular (for Web) uses 1099 in default. Set a port number to specify from 1099 of the default to the recommended value 25000 or more in Hitachi Storage Navigator Modular 2 installation. If the same port number is set, Storage Navigator Modular (for Web) or Hitachi Storage Navigator Modular 2 does not run normally.

When connecting the array unit with Hitachi Storage Navigator Modular 2 over a LAN, the array unit may not be able to connect because a time-out of the data transfer occurs. This will depend on the LAN environment. When Hitachi Storage Navigator Modular 2 cannot be connected with the array unit, verify that the connection is correct using the **ping** command. If a response to the **ping** command is normal, the LAN environment may affect the data transfer. The length of data to be transferred can be changed with the "lanconf.inf" file in the directory in which Hitachi Storage Navigator Modular 2 is installed. The default setting is "32768". Change the setting to "16384" or "8192", in this order or to a multiple of 1024, and then retry. The new setting becomes effective from the next operation. A restart of Hitachi Storage Navigator Modular 2 is not required. Operation of Hitachi Storage Navigator Modular 2 may take some time, depending on the setting. If the connection cannot be made regardless of the setting change, review the LAN environment.

If you execute the command during the firmware updating or controller recovery, the LAN becomes unusable and the operation may fail. In this case, execute it again after completing the firmware updating or controller maintenance.

If an array unit failure is detected, contact the Hitachi Customer Engineer.

Do not use the reserved words prescribed for each OS and device names that indicate the input/output destinations as a file name when a file is output. Windows includes "con", "pm", "aux", etc. For example, when con is specified as an output file name, an error message displays.



If Google Toolbar is installed in the browser, some functions may not run normally. Do not install Google Toolbar in the browser to display Hitachi Storage Navigator Modular 2.

Do not use the character size other than that of the display. The screen may not be displayed correctly by changing the browser setting. When you change the screen, operate Hitachi Storage Navigator Modular 2 screen. If you operate it with the **Back Space** key, the screen may not be displayed correctly.

Hitachi Storage Navigator Modular 2 does not support the screen transition function of the Web browser. For Internet Explorer, the following operation methods are available for returning to the Web screen displayed just before. However, if you execute those methods in Hitachi Storage Navigator Modular 2, the screen may not change.

- (1) Pressing the **Back Space** key

- (2) Pressing the ← key while holding down the **Alt** key
- (3) Operating the mouse wheel while holding down the **Shift** key
- (4) Selecting **Back** of the menu displayed by right-clicking, etc.

If you execute any of the above operations (1), (2), and (3) in the screen displayed by clicking the **Create** or **Edit** button, the screen **Now loading** is displayed and it may not change. In this case, close the screen by pressing the  button on the upper right of the screen and execute the operation again. If you have executed it in the other screen, display the screen by selecting the other tree or close the screen by pressing the  button on the upper right of the screen and execute the operation again.

- Do not delete it by selecting the installation directory of Hitachi Storage Navigator Modular 2. If you delete the installation directory, not only the operation of the operation becomes impossible but also installation and un-installation become impossible, and reinstallation of the OS may be required.
- If without installing JRE and operate it from the client of Hitachi Storage Navigator Modular 2, the Applet screen and ACE tool screen are displayed as shown in the figure below. Terminate Hitachi Storage Navigator Modular 2, install JRE correctly, and then execute Hitachi Storage Navigator Modular 2 again.

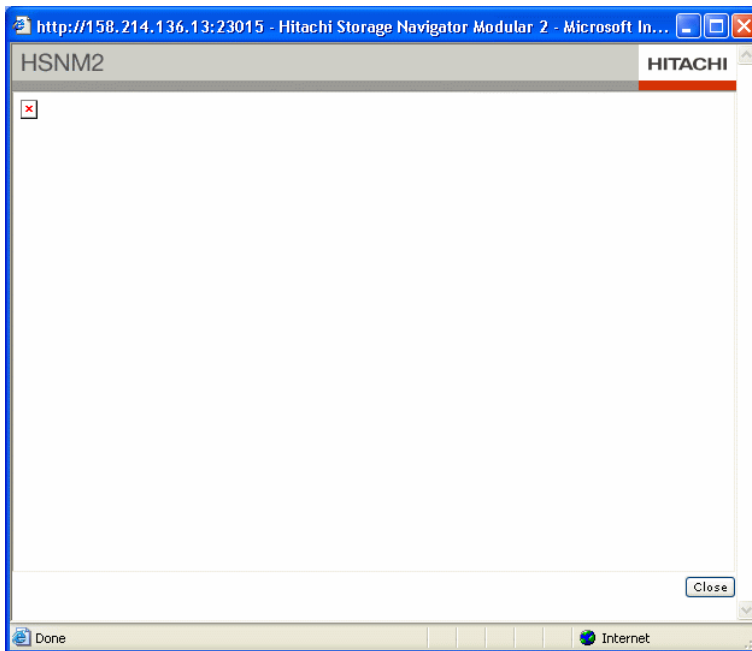

- A problem such that Hitachi Storage Navigator Modular 2 screen is not displayed correctly and pressing the button does not work depending on the setting of the browser security. When using Internet Explorer 6 as a client, register the IP address of the server of Hitachi Storage Navigator Modular 2 or a host name in the "Trusted sites". Besides, check that the following items are enabled in the setting of the "Trusted sites" security. (They are enabled in the default setting.)

- Run ActiveX controls and plug-ins
 - Script ActiveX controls marked safe for scripting
 - Active scripting
 - Submit nonencrypted form data
- When Japanese is registered as a language of the browser, the display is shown in Japanese regardless of an OS language and characters are not displayed correctly if using an OS language other than Japanese. When using an OS language other than Japanese, do not add Japanese to the browser language. When English is registered as a language of the browser being placed above Japanese, characters are displayed in English. The Applet screen is displayed in Japanese when using Japanese or in English when using an OS language other than Japanese regardless of the registration of languages.
 - When connecting Hitachi Storage Navigator Modular 2 by IPv6, if the temporary address of IPv6 is set to Enabled in the installed computer and many temporary addresses are registered, the processing time becomes long. Check the temporary addresses and if many are set, disable them.
 - The IPv6 multicast of the link local scope is used for the array search by the IPv6 address. When performing the array search, set up the array and the computer in which Hitachi Storage Navigator Modular 2 is installed in the same link.

Environment

Hitachi Storage Navigator Modular 2 is operated by connecting to the array unit over a LAN. When an array unit is connected to a LAN, the host, in which Hitachi Storage Navigator Modular 2 is installed, must be connected with the network and must operate normally.

Windows

- Host OS support:

Operating System		Remarks
Name	Service Pack	
Windows XP (x86)	SP2, SP3	
Windows Server 2003 (x86)	SP1, SP2	
Windows Server 2003 R2 (x86)	Non SP, SP2	
Windows Server 2003 R2 (x64)	Non SP, SP2	
Windows Vista (x86)	SP1	
Windows Server 2008 (x86)	Non SP, SP2	
Windows Server 2008 (x64)	Non SP, SP2	
Windows 7 (x86)	Non SP	
Windows 7 (x64)	Non SP	
Windows Server 2008 R2 (x64)	Non SP	



Note: The 64-bit Windows platform is not supported except Windows Server 2003 R2 (x64), Windows Server™ 2008 (x64), Windows 7 (x64) (AMS 2000 only), or Windows Server 2008 R2 (x64) (AMS 2000 only).

- Virtual OS: The following table shows the supported Windows platforms for virtual OS:

Host Operating System	Guest Operating System
VMWare ESX Server 3.x	Windows XP
	Windows Server 2003 R2
Windows Server 2008 R2 (x64) (Hyper-V2)	Windows Server 2008 R2 (x64)

- Operating environment of guest OS is same as normal operating environments.

The following specifications show the operating environments of Hitachi Storage Navigator Modular 2:

- CPU: Minimum 1 GHz (2 GHz or more is recommended)
- Memory: 1 GB or more (2 GB or more is recommended)

When using Hitachi Storage Navigator Modular 2 and other software products together, the memory capacity totaling the value of each software product is required.

- Available disk capacity: A free capacity of 1.5 GB or more is required.

- Client

- OS: Windows 2000 (SP3, SP4), Windows XP (SP2), Windows Server 2003 (SP1, SP2), Windows Server 2003 R2, Windows Server 2003 R2 (x64), Windows Vista, Windows Server™ 2008 (Non SP, SP2) for both x32 and x64, Windows 7 (x64) (AMS 2000 only). The 64-bit Windows is not supported except Windows Server 2003 R2 (x64), Windows 7 (x64) (AMS 2000 only), or Windows Server™ 2008 R2 (x64) (AMS 2000 only).

Windows XP and Windows Server 2003 R2 operate as a GUEST OS of the VMWare ESX Server 3.1.x.

You must apply the newest (KB922760 or newly) Windows Update.

- Browser: IE6.0 (SP1, SP2) or IE7.0. The 64-bit IE6 (SP1, SP2) on Windows Server 2003 R2 (x64) and the 64-bit-IE7.0 on windows Server 2008 (x64) is supported.
- Only IE8.0 (x86, x64) is supported on Windows 7 and Windows Server 2008 R2.
- JRE: JRE 1.6.0_15. The 64-bit JRE is not supported. For more installation about JRE, refer to java download page.

The JRE download from <http://java.com/en/download/>, and then install JRE.

- CPU: (1 GHz or more is recommended)
- Memory: 1 GB or more (2 GB or more is recommended)

When using Hitachi Storage Navigator Modular 2 and other software products together, the memory capacity totaling the value of each software product is required.

- Available disk capacity: A free capacity of 100 MB or more is required.
- Monitor: Resolution 800 × 600, 1,024 × 768 or more is recommended, 256 color or more.

Red Hat Linux

- Host
 - OS: Red Hat Enterprise Linux AS 4.0 update1, Red Hat Enterprise Linux AS 4.0 update5, Red Hat Enterprise Linux 5.3 (excluding SELinux)
Not supported update from Red Hat Enterprise Linux AS 4.0 to update. Supported only x86 environment.
 - CPU: Minimum 1 GHz (2 GHz or more is recommended)
 - Memory: 1 GB or more (2 GB or more is recommended)
When using Hitachi Storage Navigator Modular 2 and other software products together, the memory capacity totaling the value of each software product is required.
 - Available disk capacity: A free capacity of 1.5 GB or more is required.
- Client
 - OS: Red Hat Enterprise Linux AS 4.0 update1, Red Hat Enterprise Linux AS 4.0 update5, Red Hat enterprise Linux 5.3 (excluding SELinux)
Not supported update from Red Hat Enterprise Linux AS 4.0 to update. Supported only x86 environment.
 - Browser: Mozilla 1.7
 - JRE: JRE 1.6.0_15
The JRE download from <http://java.com/en/download/>, and then install JRE.
 - CPU: (1 GHz or more is recommended)
 - Memory: 1 GB or more (2 GB or more is recommended)
When using Hitachi Storage Navigator Modular 2 and other software products together, the memory capacity totaling the value of each software product is required.
 - Available disk capacity: A free capacity of 100 MB or more is required.
 - Monitor: Resolution 800 × 600, 1,024 × 768 or more is recommended, 256 color or more.

Solaris

- Host
 - OS: Solaris 8 (SPARC).
Solaris 9 (SPARC)
Solaris 10 (SPARC), or
Solaris 10 (x64)

- CPU: SPARC minimum 1 GHz (2 GHz or more is recommended)
Solaris 10 (x64): Minimum 1.8 GHz (2 GHz (2 GHz or more is recommended)

Not supported x86 processor as like Opteron.

Solaris 10 (x64) is supported 64 bits kernel mode on Sun Fire x64 server family only. Do not change the kernel mode to other than 64 bits after installing Hitachi Storage Navigator Modular 2.

- Memory: 1 GB or more (2 GB or more is recommended)
When using Hitachi Storage Navigator Modular 2 and other software products together, the memory capacity totaling the value of each software product is required.
- Available disk capacity: A free capacity of 1.5 GB or more is required.
- JDK: JDK1.5.0 is required.

- Client

- OS: Solaris 8
Solaris 9 (SPARC)
Solaris 10 (SPARC)
Solaris 10 (x86), or
Solaris 10 (x64)

- CPU: SPARC minimum 1 GHz (2 GHz or more is recommended)
Solaris 10 (x64): Minimum 1.8 GHz (GHz or more is recommended)
Not supported x86 processor as like Opteron.

Solaris 10 (x64) is supported 64-bit kernel mode on Sun Fire x64 server family only. Do not change the kernel mode to other than 64 bits after installing Hitachi Storage Navigator Modular 2.

- Browser: Mozilla 1.7, Firefox 2
- JRE: JRE 1.6.0_15

The JRE download from <http://java.com/en/download/>, and then install JRE.

- CPU: (1 GHz or more is recommended)
- Memory: 1 GB or more (2 GB or more is recommended)
When using Hitachi Storage Navigator Modular 2 and other software products together, the memory capacity totaling the value of each software product is required.
- Available disk capacity: A free capacity of 100 MB or more is required.
- Monitor: Resolution 800 × 600, 1,024 × 768 or more is recommended, 256 color or more.

Common Environment

- LAN connection
 - Connect one of the LAN cables to the LAN port of the controller #0 or controller #1 of the array unit.
 - Connect the other of the LAN cables to the LAN-HUB prepared by a customer or the LAN port of the host for controlling the array unit.
 - The LAN port supports the function (Auto MDI/MDX) to automatically distinguish the LAN cable type (straight or cross). Therefore, you can connect it with the straight cable when connecting to the LAN-HUB and directly connecting to the host for controlling the array unit.
- Port number of TCP/IP
 - When connecting the array unit and a LAN, Hitachi Storage Navigator Modular 2 uses the port number of 2000. When changing the port number, add "df-damp-snm port number/TCP" to the services file of the OS. In addition, when changing the port number, it is also required to change the port number of the array unit to be connected. When the port number of the array unit is set as 2000, the array unit can be connected to the LAN though it takes time for the connection even if another port number is registered in the services file.

IPv6 Supported Platforms

Table 1.2 shows the IPv6 supported platforms.

Table 1.2 IPv6 Supported Platforms

Vendor	Operating System		IPv6 Supported
	Name	Service Pack	
SUN	Solaris 8 (SPARC)	-	Supported
	Solaris 9 (SPARC)	-	Supported
	Solaris 10 (SPARC)	-	Supported
	Solaris 10 (x86)	-	Supported only client
	Solaris 10 (x64)	-	Supported
Microsoft	Windows Server 2003 (x86)	SP1	Supported
	Windows Server 2003 (x86)	SP2	Supported
	Windows Server 2003 R2 (x86)	SP1	Supported
	Windows Server 2003 R2 (x64)	SP1	Supported
	Windows Vista (x86)	SP1	Supported
	Windows Server 2008 (x86)	SP1, SP2	Supported
	Windows Server 2008 (x64)	SP1, SP2	Supported
Red Hat	Red Hat Enterprise Linux AS 4.0 update1	-	Address searching function is not supported on the server.
	Red Hat Enterprise Linux AS 4.0 update5	-	Address searching function is not supported on the server.
	Red Hat Enterprise Linux 5.3	--	Supported

Connecting Hitachi Storage Navigator Modular 2 to the Host

You can connect Hitachi Storage Navigator Modular 2 to a host through a LAN with or without a switch.

When two or more LAN cards are installed in a host and a segment set in each LAN card is different from the others, Hitachi Storage Navigator Modular 2 can only access from the LAN card side specified by the installer. When accessing the array unit from the other segment, make the configuration that a router is used. Install one LAN card in the host to be installed.



Note: If an array unit is already connected with a LAN, a host is connected to the same network as the array unit.

Installing Hitachi Storage Navigator Modular 2

When Storage Navigator Modular is installed, Hitachi Storage Navigator Modular 2 cannot perform updating installation from Storage Navigator Modular.

Preparation

Make sure of the following on the host in which Hitachi Storage Navigator Modular 2 is to be installed before starting installation:

When the preparation items are not done correctly, installation may not be completed. It is usually completed in about 30 minutes. If it is not completed even one hour or more passes, terminate the installer forcibly and check that the preparation items are correctly done.

- For Windows, you are logged on to Windows as an Administrator or a member of the Administrators group.
For Linux and Solaris, you are logged on to as a root user.
- To install Hitachi Storage Navigator Modular 2, it is required to the following free disk capacity.

OS	Directory	Free Disk Capacity
Windows	Installed directory	1.5 GB
Linux	/opt/HiCommand	1.5 GB
Solaris	/opt/HiCommand	1.5 GB
	/var/opt/HiCommand	1.0 GB
	/var/tmp	1.0 GB

When install Hitachi Storage Navigator Modular 2, it is not required exits the above directory. If directories don't exist, above directories are required to have enough free space.

- For Linux and Solaris, when the /opt exists, the normal directory is required (not the symbolic link). However, the file system may be mounted as a mount point.
- For Linux and Solaris, the kernel parameters must be set correctly. For more details, see section 0 or 0.
- The following patch must be applied to Solaris 10 (SPARC).
The patch 120664-xx (xx: 01 or later)
The patch 127127-xx (xx: 11 or later)
Do not apply the patch 127111-02 and 127111-03
- The following patch must be applied to Solaris 10 (x64).

The patch 120665-xx (xx: 01 or later)

Do not apply the patch 127112-02 and 127112-03

- Products other than Hitachi Storage Command Suite Common Component are not using port numbers 1099, 23015 to 23018, 23032, and 45001 to 49000.

If other products are using these ports, you cannot start Hitachi Storage Navigator Modular 2, even if the installation of Hitachi Storage Navigator Modular 2 has finished normally. Make sure that no other products are using these ports, and then begin the installation. You can change the port numbers 1099 and 23015 after the installation. Refer to section 0 more details. If these port numbers have already been changed and used in an environment where Hitachi Storage Command Suite Common Component is installed, you can use the changed port numbers to install Hitachi Storage Navigator Modular 2. You do not have to change the port numbers back to the default.

- No other Hitachi Storage Command product is running.

When applications are running, stop the services (daemon process) according to the operation manual of each application.

- The installed Hitachi Storage Command Suite Common Components must not be operated in a cluster configuration.

When the host is in the cluster configuration, you cannot install Hitachi Storage Navigator Modular 2. In case of a cluster configuration, change it to the stand-alone configuration according to the manual.

- Dialog boxes used for operating Windows services, such as Computer Management or Services, are not displayed.

When you display a window, you may not be able to install Hitachi Storage Navigator Modular 2. If the installation is not completed after one hour elapsed, terminate the installation forcibly and check if the window is displayed.

- Services (daemon process) such as process monitoring and virus monitoring must not be operating.

When the service (daemon process) is operating, you may not be able to install Hitachi Storage Navigator Modular 2. If the installation is not completed after one hour elapsed, terminate the installation forcibly and check what service (daemon process) is operating.

- When third-party-made firewall software other than Windows firewall is used, it must be invalidated during the installation or un-installation.

When you are using the third party- made firewall software, if the installation of Hitachi Storage Navigator Modular 2 is not completed after one hour elapsed, terminate the installation forcibly and check if the third party-made firewall software is invalidated.

- For Linux and Solaris environment, the firewall is must be invalidated.

To invalidate the firewall, see the each firewall manual.

- Some of the firewall functions provided by the OS might terminate socket connections in the local host. You cannot install and operate Hitachi Storage Navigator Modular 2 in an environment in which socket connections are terminated in the local host. When setting up the firewall provided by the OS, configure the settings so that socket connections cannot be terminated in the local host.
- Windows must be set to produce the 8+3 form file name that is compatible with MS-DOS.

There is no problem because Windows creates the 8+3 form file name in the standard setting. When the tuning tool of Windows is used, the standard setting may have been changed. In that case, return the setting to the standard one.

- Hitachi Storage Navigator Modular 2 for Windows supports the Windows Remote Desktop functionality. Note that the Microsoft terms used for this functionality differ depending on the Windows OS. The following terms can refer to the same functionality:
 - Terminal Services in the Remote Administration mode
 - Remote Desktop for Administration
 - Remote Desktop connection

When using the Remote Desktop functionality to perform Hitachi Storage Navigator Modular 2 operation (including installation or un-installation), you need to connect to the console session of the target server in advance. However, even if you have successfully connected to the console session, the product might not work properly if another user connects to the console session.

- Windows must be used in the application server mode of the terminal service and must not be installed in the execution mode.

When installing Hitachi Storage Navigator Modular 2, do not use the application server mode of the terminal service. If the installer is executed in such an environment, the installation may fail or the installer may become unable to respond.



Note: Before installing Hitachi Storage Navigator Modular 2 on a host in which another Hitachi Storage Command product has already been installed, back up the database. However, you install Hitachi Storage Navigator Modular 2 only, it is not necessary to back up.



Note: When installing Hitachi Storage Navigator Modular 2 in Windows Server 2003 SP1 or Windows XP SP2 or later, you need to specify the following settings if Data Execution Prevention is being used:

Settings When Data Execution Prevention Is Enabled

If Data Execution Prevention (DEP) is enabled in Windows, sometimes installation cannot start. In this case, use the following procedure to disable DEP and then re-execute the installation operation.

To disable DEP:

1. Choose **Start, Settings, Control Panel**, and then **System**.
The **System Properties** dialog box appears.
2. Select the **Advanced** tab, and under **Performance** click **Settings**.
The **Performance Options** dialog box appears.
3. Select the **Data Execution Prevention** tab, and select the **Turn on DEP for all programs and services except those I select** radio button.
4. Click **Add** and specify Hitachi Storage Navigator Modular 2 installer (HSNM2-xxxx-W-GUI.exe). (The portion "xxxx" of file names varies with the version of Hitachi Storage Navigator Modular 2, etc.)
Hitachi Storage Navigator Modular 2 installer (HSNM2-xxxx-W-GUI.exe) is added to the list.
5. Select the checkbox next to Hitachi Storage Navigator Modular 2 installer (HSNM2-xxxx-W-GUI.exe) and click **OK**.

Automatic exception registration of Windows firewall:

When Windows firewall is used, the installer for Hitachi Storage Navigator Modular 2 automatically registers the file of Hitachi Storage Navigator Modular 2 and that included in Hitachi Storage Command Suite Common Components as exceptions to the firewall. Check that no problems of security exist before executing the installer.

Setting of Linux Kernel Parameters

When install Hitachi Storage Navigator Modular 2 to Linux, you must be set the Linux kernel parameters. If you not set the Linux kernel parameters, Hitachi Storage Navigator Modular 2 installer terminates abnormally. Besides, when the application have already been installed and used in an environment where Hitachi Storage Command Suite Common Component, the Linux kernel parameters are not required to set.

To set the Linux kernel parameters:

1. Backup the kernel parameters setting file (/etc/sysctl.conf and /etc/security/limits.conf).
2. Open the kernel parameters setting file (/etc/sysctl.conf) with text editor and change referring to the following.

The parameters are specified using the form, which is "[name of parameter]=[value]". Four values separated by space are specified in kernel.sem.

Then, the parameter must not exceed the maximum value that OS specifies.

The value can be checked by the following command.

cat /proc/sys/kernel/shmmax (Case: Check value of "kernel.shmmax")

Parameter Name	Recommended Value		Calculation Method
	Navigator 2	Data Base	
kernel.shmmax	11542528	200000000	The maximum value in current and two recommended value.
kernel.shmall	22418432	22418432	The total value of current value and recommended value.
kernel.shmmni	0	2000	The larger value in following: <ul style="list-style-type: none"> ▪ The total value of current and Navigator 2 recommended value ▪ The data base recommended value
kernel.threads-max	184	574	
kernel.msgmni	32	32	
kernel.sem (Second parameters)	80	7200	
kernel.sem (Forth parameters)	9	1024	
fs.file-max	53898	53898	

3. Open the kernel parameters setting file (/etc/security/limits.conf) with text editor and change referring to the following.

The parameters are specified using the form, which is "[domain] [type] [name of parameter] [value]". The domains are specified for "*". The types are specified for both "soft" and "hard". Then the soft value must not exceed the hard value. Then, the parameter must not exceed the maximum value that OS specifies.

Parameter Name	Recommended Value		Calculation Method
	Navigator 2	Data Base	
nofile	572	1344	The larger value in following: <ul style="list-style-type: none"> ▪ The total value of current and Navigator 2 recommended value ▪ The data base recommended value
nproc	165	512	

4. Reboot host.

Setting of Solaris 8 or Solaris 9 Kernel Parameters

When install Hitachi Storage Navigator Modular 2 to Solaris 8 or Solaris 9, must be set the Solaris kernel parameters. If you not set the Solaris kernel parameters, Hitachi Storage Navigator Modular 2 installer terminates abnormally. Besides, when the application have already been installed and used in an environment where Hitachi Storage Command Suite Common Component, the Solaris kernel parameters are not required to set.

To set the Solaris kernel parameters:

1. Backup the kernel parameters setting file (/etc/system).
2. Open the kernel parameters setting file (/etc/system) with exit editor and add the following text line to bottom.

When a certain value has been set in the file, revise the existing value by adding the following value within the limit that the value does not exceed the maximum value which each OS specifies. For the maximum value, refer to the manual of each OS.

```
set msgsys:msginfo_msgmni=82
set msgsys:msginfo_msgtql=520
set semsys:seminfo_semmni=1024
set semsys:seminfo_semmns=7200
set semsys:seminfo_semmnu=1024
set semsys:seminfo_semume=512
set semsys:seminfo_semmsl=128
set semsys:seminfo_semopm=128
set shmsys:shminfo_shmmax=200000000
set shmsys:shminfo_shmmni=2000
set shmsys:shminfo_shmseg=240
```



Note: The shmsys:shminfo_shmseg is not used in Solaris 9. But there is no influence even if sets it.

3. Reboot the Solaris host and then install Hitachi Storage Navigator Modular 2.

Setting of Solaris 10 Kernel Parameters

When install Hitachi Storage Navigator Modular 2 to Solaris 10, must be set the Solaris kernel parameters. If you not set the Solaris kernel parameters, Hitachi Storage Navigator Modular 2 installer terminates abnormally. Besides, when the application have already been installed and used in an environment where Hitachi Storage Command Suite Common Component, the Solaris kernel parameters are not required to set.

To set the Solaris kernel parameters:

1. Backup the kernel parameters setting file (/etc/project).
2. From the consol, execute the following command and then check the current parameter value.

```
prctl -i project 'user.root'  
prctl -i project 'system'
```

3. From the consol, execute the following command and then set the parameters.

When a certain value has been set, revise the existing value by adding the following value within the limit that the value does not exceed the maximum value which each OS specifies. For the maximum value, refer to the manual of each OS.

The parameter must be set for the both projects, user.root and system.

```
projmod -a -K 'process.max-msg-messages=(priv,480,deny)' 'user.root'  
projmod -a -K 'process.max-sem-nsems=(priv,128,deny)' 'user.root'  
projmod -a -K 'process.max-sem-ops=(priv,128,deny)' 'user.root'  
projmod -a -K 'project.max-msg-ids=(priv,32,deny)' 'user.root'  
projmod -a -K 'project.max-sem-ids=(priv,1024,deny)' 'user.root'  
projmod -a -K 'project.max-shm-ids=(priv,2000,deny)' 'user.root'  
projmod -a -K 'project.max-shm-memory=(priv,26214400,deny)' 'user.root'  
projmod -a -K 'process.max-msg-messages=(priv,480,deny)' 'system'  
projmod -a -K 'process.max-sem-nsems=(priv,128,deny)' 'system'  
projmod -a -K 'process.max-sem-ops=(priv,128,deny)' 'system'  
projmod -a -K 'project.max-msg-ids=(priv,32,deny)' 'system'  
projmod -a -K 'project.max-sem-ids=(priv,1024,deny)' 'system'  
projmod -a -K 'project.max-shm-ids=(priv,2000,deny)' 'system'  
projmod -a -K 'project.max-shm-memory=(priv,26214400,deny)' 'system'
```

4. Reboot the Solaris host and then install Hitachi Storage Navigator Modular 2.



Note: In case of the setting of the kernel parameters is not enabled in Solaris 10, open the file (/etc/system) with text editor and change referring to the following before reboot host.

```
set msgsys:msginfo_msgmni=128  
set msgsys:msginfo_msgtql=8192  
set semsys:seminfo_semmni=1024  
set semsys:seminfo_semmsl=512  
set semsys:seminfo_semopm=512  
set shmsys:shminfo_shmmax=262144000  
set shmsys:shminfo_shmmni=2000
```

Installing

You need to specify the following items when installing Hitachi Storage Navigator Modular 2 for the first time. Check these items before the installation.

- Host name or IP address of the host that installing Hitachi Storage Navigator Modular 2 (If two or more IP addresses set on the host)
- Port number (1099 must not be used as a port number)

If 1099 is used as a port number, replace it to a port number currently not used. We recommend using a number 25000 or more for a port number.

To perform a new installation for Windows:



Note: In the case of Windows Vista, open the command prompt and then close it before starting the installation.

1. Insert Hitachi Storage Navigator Modular 2 installation CD-ROM.

The installation starts automatically. If you perform the installation later, terminate it. After that, display the contents of the CD-ROM with Explorer and execute HSNM2-xxxx-W-GUI.exe. (The portion "xxxx" of file names varies with the version of Hitachi Storage Navigator Modular 2, etc.)

The **Welcome to the InstallShield Wizard for Hitachi Storage Navigator Modular 2** dialog box appears.

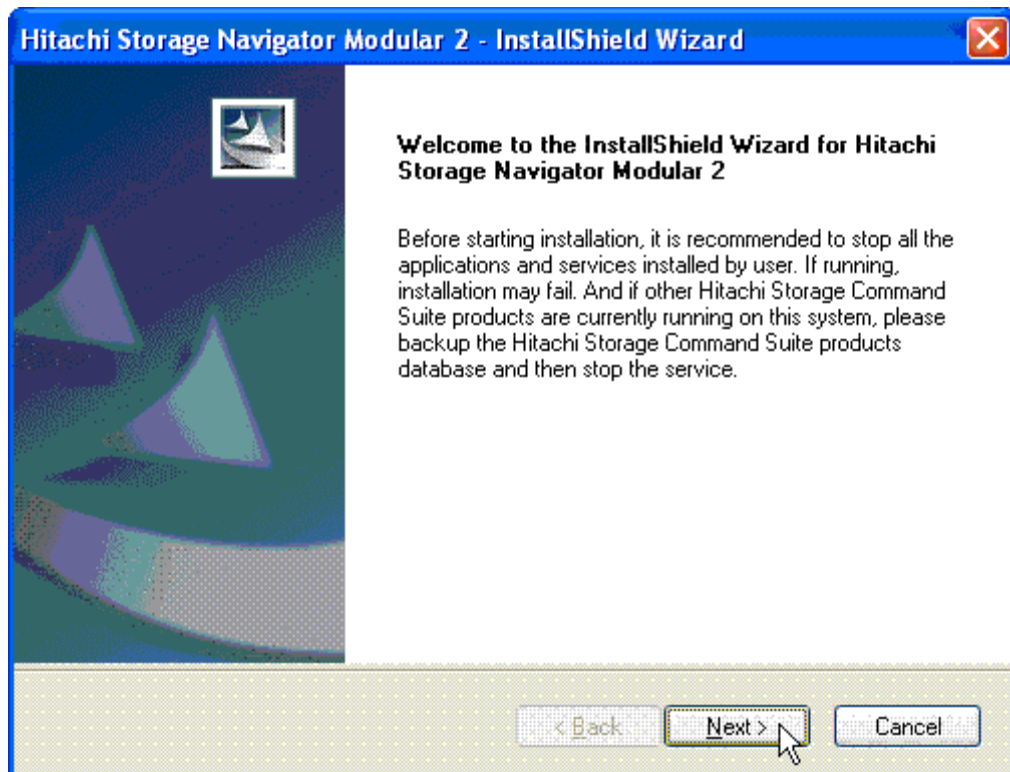

2. Click **Next**.

Click **Next** to display the **Choose Destination Location** dialog box.

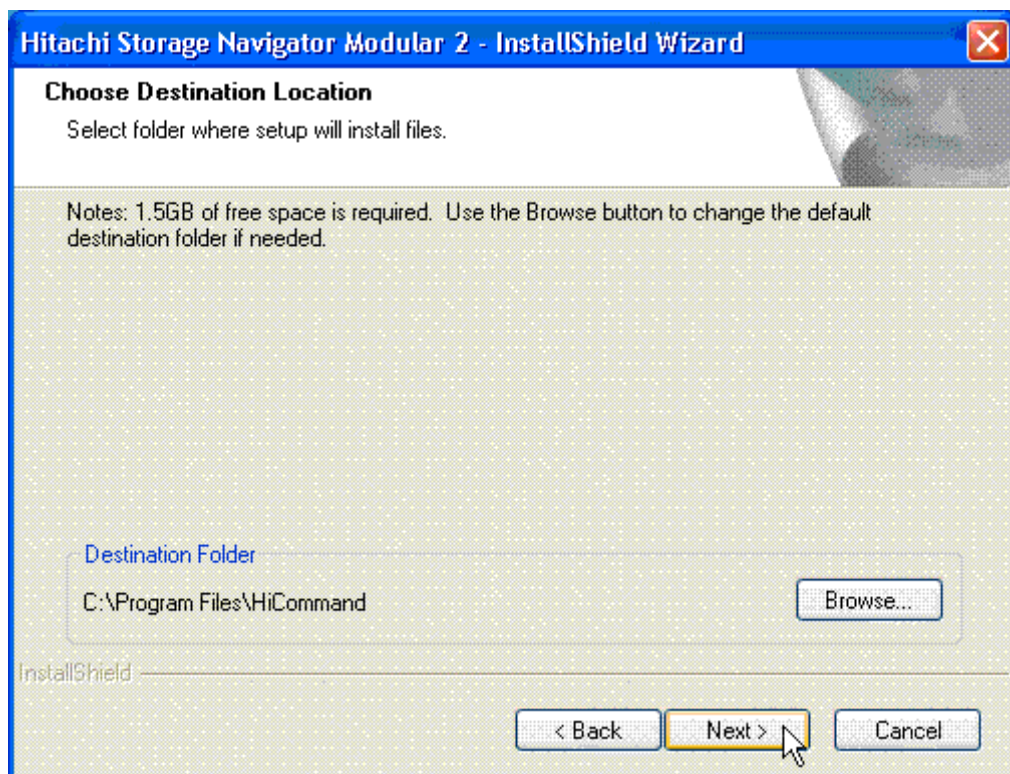

We recommend installing Hitachi Storage Navigator Modular 2 in the default folder. If you do not want to accept the default installation folder, specify another installation folder. The rules for specifying an installation folder are as follows:

- Only the following characters can be used:
A to Z, a to z, 0 to 9, hash mark (#), plus sign (+), hyphen (-), period (.), at mark (@), underscore (_), and the space character.
Note that a space character cannot be used at the beginning or end of a folder name.
- The path name must not contain any names reserved by the OS (CON, AUX, NUL, PRN, CLOCK\$, COM1 to COM9, and LPT1 to LPT9).
- Do not specify the UNC path.
- For the directory specification of the installation destination, the length of the character string is within 100 characters and do not specify a route of the drive. If you specify a route of the drive, the installer displayed a following error message in the middle of the installation.

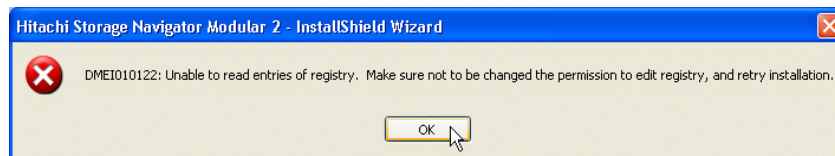

The installer creates the `_HDBInstallerTemp` and `StorageNavigatorModular` directories. Delete the `_HDBInstallerTemp` and `StorageNavigatorModular` directories if necessary.

If you install Hitachi Storage Navigator Modular 2 on a host in which other Hitachi Storage Command products are not installed, Hitachi Storage Navigator Modular 2 and Hitachi Storage Command Suite Common Component will be installed in the folder that is specified in the **Setup of the Installation Folder** dialog box.

If you install Hitachi Storage Navigator Modular 2 on a host in which other Hitachi Storage Command products are installed, Hitachi Storage Navigator Modular 2 will be installed in the folder that is specified in the **Setup of the Installation Folder** dialog box, but Hitachi Storage Command Suite Common Component will be installed in the folder that contains the existing Hitachi Storage Command Suite Common Component, and overwrites it.

A volume with a folder of Hitachi Storage Navigator Modular 2 installation destination must have a capacity of 1.5 GB or more.

3. Click **Next**.

The **Input the IP address and port number of the PC** dialog box appears.

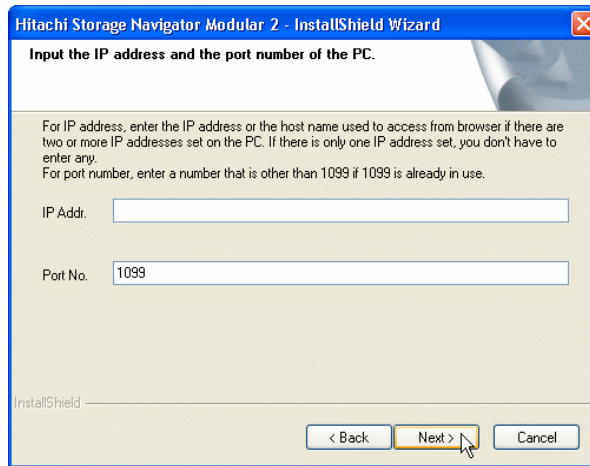

Specify the following information (confirm the information before you start installation):

- IP Addr.: Set an IP address or a host name to display the Applet screen. Specify an IP address or a host name to install Hitachi Storage Navigator Modular 2.

If only one IP address is set to the host to install Hitachi Storage Navigator Modular 2, it is not required to set the IP address. Set it when two or more IP addresses are set to the host to install Hitachi Storage Navigator Modular 2.



Note: Do not specify 127.0.0.1 and localhost. If you specify it, the Applet screen of Hitachi Storage Navigator Modular 2 is not displayed.



Note: Port No.: Port number for SNM2 Server. The default value is 1099.

When Storage Navigator Modular (for Web) is installed or run in the same host, specify a value other than 1099. When the port number is changed in Storage Navigator Modular (for Web) setting, specify a port number other than the changed value.



Note: When using DHCP environments, specify host name (computer name) to the **IP Addr.** field.

4. Click **Next**.

Clicking **Next** displays the **Start Copying Files** dialog box.

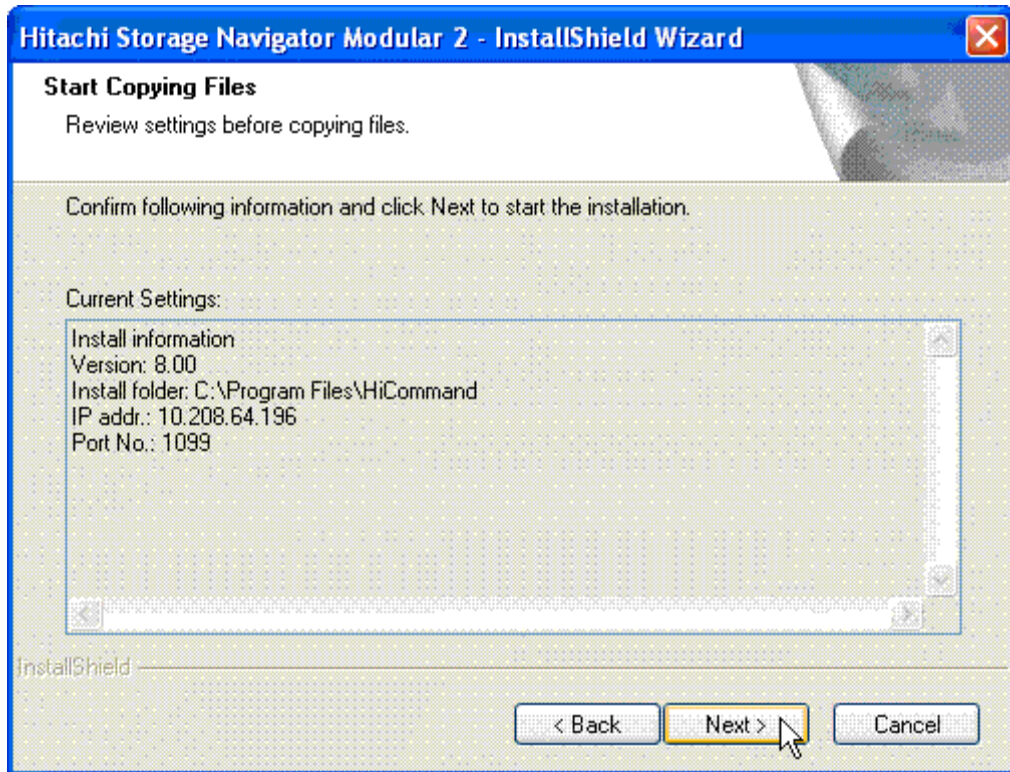

Parameters about the installation are displayed. Confirm that they are correct. If you find any mistake, return to the previous dialog box click **Back** and correct it.

5. Confirm that the displayed installation settings are correct, and then click **Next**.

Installation starts. During the installation, dialog boxes indicating the processing status appear. When installation is complete, the **InstallShield Wizard Complete** dialog box appears. The installation cannot be stopped after it is started.

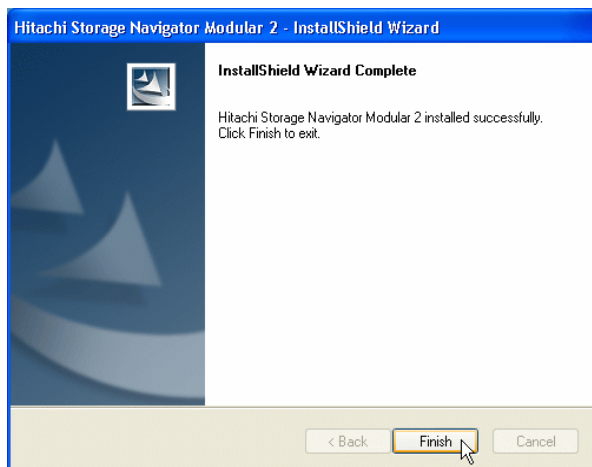

6. Click **Finish** to finish the installation.

When the installation completes normally, you can operate via a Web browser. Refer to section 0 for the procedures to set a client and to access Hitachi Storage Navigator Modular 2.

To perform a new installation for Linux:

1. Insert Hitachi Storage Navigator Modular 2 installation CD-ROM.
2. Mount the CD-ROM on the file system. The mount destination is `/cdrom` here.
3. From the console, execute the following command.

```
sh /cdrom/install-hsnm2.sh -a [ IP address ] -p [ port number ]
```

Specify the IP address or host name used to access Hitachi Storage Navigator Modular 2 and the port number for the IP address and port number. However, if you use 1099 for the port number, you can omit the `-p` option. You cannot omit the `-a` option.



Note: Do not specify 127.0.0.1 and localhost. If you specify it, the Applet screen of Hitachi Storage Navigator Modular 2 is not displayed.



Note: When using DHCP environments, specify host name (computer name) to the **IP Addr.** Field.

To perform a new installation for Solaris:

1. Insert Hitachi Storage Navigator Modular 2 installation CD-ROM.
2. Mount the CD-ROM on the file system. The mount destination is `/cdrom` here.
3. Create the temporary directory that to have enough free space (more than 600 MB) on the file system, and expand the compressed files. The temporary directory is `/temporary` here (XXXX is a version number).

```
mkdir /temporary  
cd /temporary  
gunzip < /cdrom/HSNM2-XXXX-S-GUI.tar.gz | tar xf -
```

4. From the console, execute the following command.

```
/temporary/install-hsnm2.sh -a [ IP address ] -p [ port number ]
```

Specify the IP address or host name used to access Hitachi Storage Navigator Modular 2 and the port number for the IP address and port number. However, if you use 1099 for the port number, you can omit the `-p` option. You cannot omit the `-a` option.

5. Delete the temporary directory.



Note: Do not specify 127.0.0.1 and localhost. If you specify it, the Applet screen of Hitachi Storage Navigator Modular 2 is not displayed.



Note: When using DHCP environments, specify host name (computer name) to the **IP Addr.** field.



Note: When installing Hitachi Storage Navigator Modular 2 in the host that cannot read the CD ROM, copy two files, install-hsnm2.sh and HSNM2-XXXX-L-GUI.rpm (Linux) or HSNM2-XXXX-S-GUI.tar.gz (Solaris) (XXXX is a version number), to the file system that can be recognized by the host and execute the command in the above procedure to install it.

Updating

When you update the installed Hitachi Storage Navigator Modular 2 to that of the newer version, you can perform the update installation using the installer.

When you install Hitachi Storage Navigator Modular 2 of the same version as that has been already installed, the uninstaller starts. Hitachi Storage Navigator Modular 2 is uninstalled and then newly installed.

If you are using it by connecting with the https, it is required to set the server certificate and private key again after completing the update. Refer to the section 0 for the setting.

Check if the preparation for the upgrade installation is completed referring to section 0.



Note: You cannot perform the update installation of Hitachi Storage Navigator Modular 2 of the former version than that of the installed Hitachi Storage Navigator Modular 2. When it is required to return to the former version, uninstall Hitachi Storage Navigator Modular 2 once. If you fail to reinstall it after uninstalling Hitachi Storage Navigator Modular 2, restart the host, check that the installation of Hitachi Storage Navigator Modular 2 is ready, and then install it again.



Note: If you perform the update installation of Hitachi Storage Navigator Modular 2 the version to 5.00 or more, the login screen showed in page 3-4 displays. If it is not displayed, operate the following contents.

- Delete the Temporary Internet files.
- Clear the History.
- Close all the screens of the open browser.

To perform an upgrade installation for Windows:

1. Insert Hitachi Storage Navigator Modular 2 installation CD-ROM.

The installation starts automatically. If you perform the installation later, terminate it. After that, display the contents of the CD-ROM with Explorer and execute HSNM2-xxxx-W-GUI.exe. (The portion "xxxx" of file names varies with the version of Hitachi Storage Navigator Modular 2, etc.)

The **Welcome to the InstallShield Wizard for Hitachi Storage Navigator Modular 2** dialog box appears.

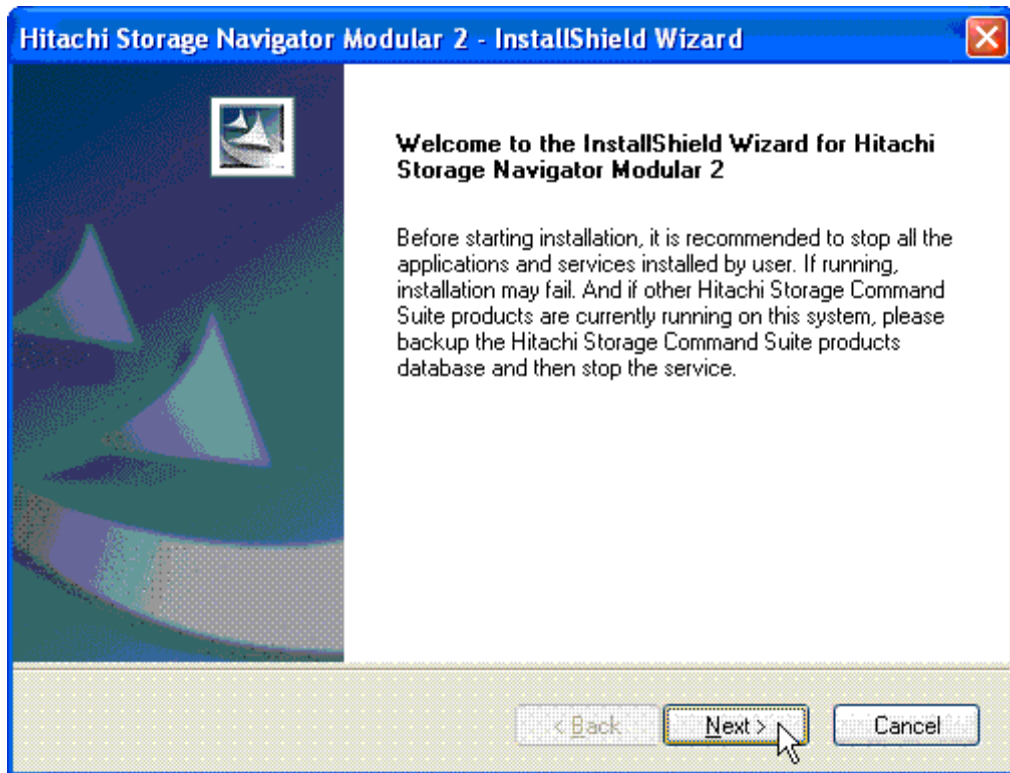

2. Click **Next**.

Clicking **Next** displays the **Confirm stopping the services** dialog box.

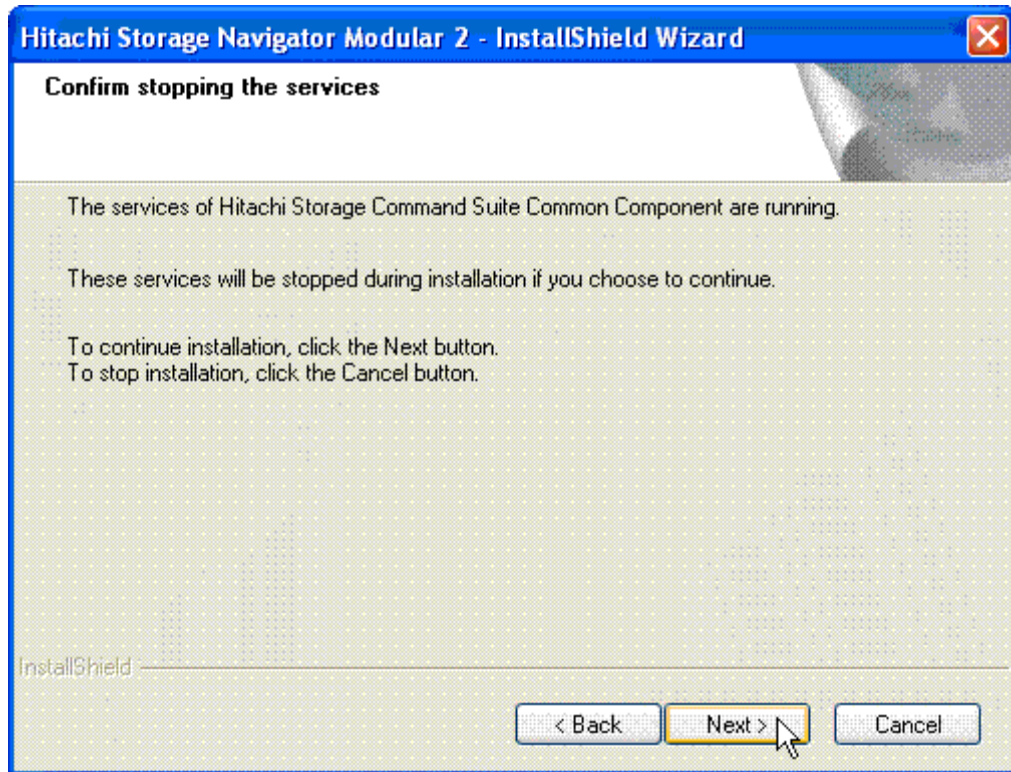

3. Click **Next**.

Clicking **Next** displays the **Confirm before updating** dialog box.

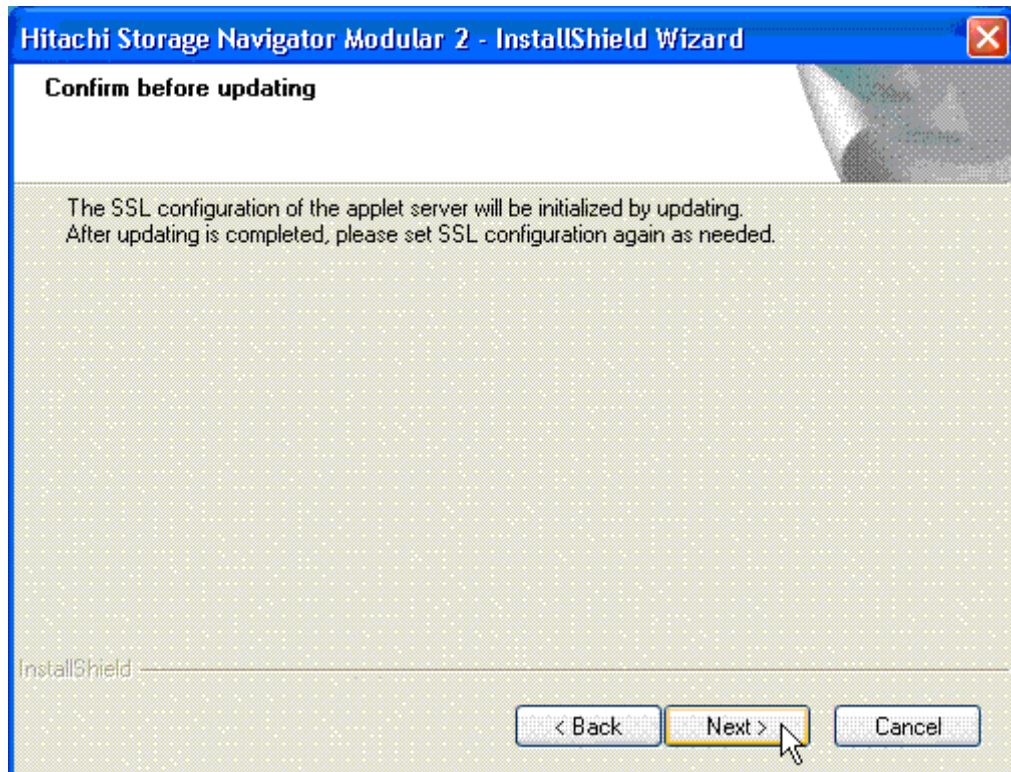

4. Confirm that the displayed information, and then click **Next**.

Installation starts. During the installation, dialog boxes indicating the processing status appear. When installation is complete, the **Update Complete** dialog box appears. The upgrade installation cannot be stopped after it is started.

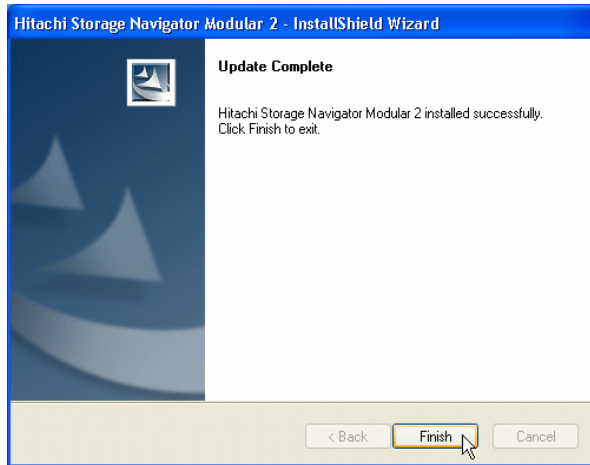

5. Click **Finish** to finish the installation.

When the installation completes normally, you can operate via a Web browser.

To perform an upgrade installation for Linux:

1. When the application that uses Hitachi Storage Command Suite Common Components other than Hitachi Storage Navigator Modular 2 is installed, stop the daemon process of the Hitachi Storage Command Suite Common Components.
2. Insert Hitachi Storage Navigator Modular 2 installation CD-ROM.
3. Mount the CD-ROM on the file system. The mount destination is `/cdrom` here.
4. From the `console`, execute the following command.

```
sh /cdrom/install-hsnm2.sh
```



Note: Do not specify `127.0.0.1` and `localhost`. If you specify it, the Applet screen of Hitachi Storage Navigator Modular 2 is not displayed.



Note: When using DHCP environments, specify host name (computer name) to the **IP Addr.** field.

To perform an upgrade installation for Solaris:

1. Insert Hitachi Storage Navigator Modular 2 installation CD-ROM.
2. Mount the CD-ROM on the file system. The mount destination is `/cdrom` here.
3. Create the temporary directory that to have enough free space (more than 600 MB) on the file system, and expand the compressed files. The temporary directory is `/temporary` here (XXXX is a version number).

```
mkdir /temporary
cd /temporary
gunzip < /cdrom/HSNM2-XXXX-S-GUI.tar.gz | tar xf -
```

4. From the console, execute the following command.

```
/temporary/install-hsnm2.sh -a [ IP address] -p [ port number ]
```

Specify the IP address or host name used to access Hitachi Storage Navigator Modular 2 and the port number for the IP address and port number. However, if you use 1099 for the port number, you can omit the `-p` option. You cannot omit the `-a` option.

5. Delete the temporary directory. Refer to the notes for best practices.



Note: Do not specify 127.0.0.1 and localhost. If you specify it, the Applet screen of Hitachi Storage Navigator Modular 2 is not displayed. When using DHCP environments, specify host name (computer name) to the **IP Addr.** field.



Note: When installing Hitachi Storage Navigator Modular 2 in the host that cannot read the CD ROM, copy two files, `install-hsnm2.sh` and `HSNM2-XXXX-L-GUI.rpm` (Linux) or `HSNM2-XXXX-S-GUI.tar.gz` (Solaris) (XXXX is a version number), to the file system that can be recognized by the host and execute the command in the above procedure to install it.

Uninstalling

Check if the preparation for the un-installation is completed referring to section 0.



Note: When other applications using Hitachi Storage Command Suite Common Components have been installed in the host to uninstall Hitachi Storage Navigator Modular 2, back up the data base of the applications before uninstalling Hitachi Storage Navigator Modular 2.



Note: When you uninstall Hitachi Storage Navigator Modular 2 and the message “forcible uninstallation is necessary” is displayed, restart the PC, check if the preparation for the un-installation is completed, and uninstall Hitachi Storage Navigator Modular 2 again. If you cannot uninstall Hitachi Storage Navigator Modular 2 even restarting the PC, you need to reinstall the OS.

To uninstall Hitachi Storage Navigator Modular 2 for Windows:

1. In the Windows **Start** menu, choose **Settings, Control Panel, Add or Remove Programs**.

The **Add or Remove Programs** panel appears.

2. From the Currently installed programs list, select **Hitachi Storage Navigator Modular 2**.
3. Click **Remove**.

The **Uninstall Hitachi Storage Navigator Modular 2** dialog box appears.

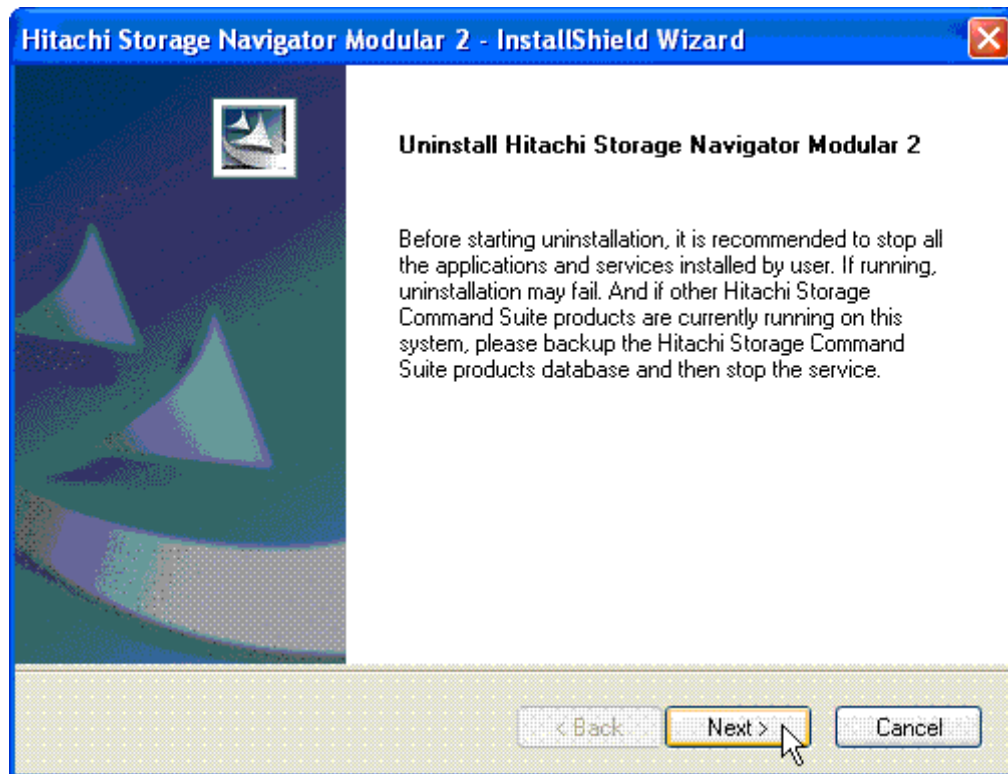

4. Click **Next**.

Clicking **Next** displays the **Confirm stopping the services** dialog box.

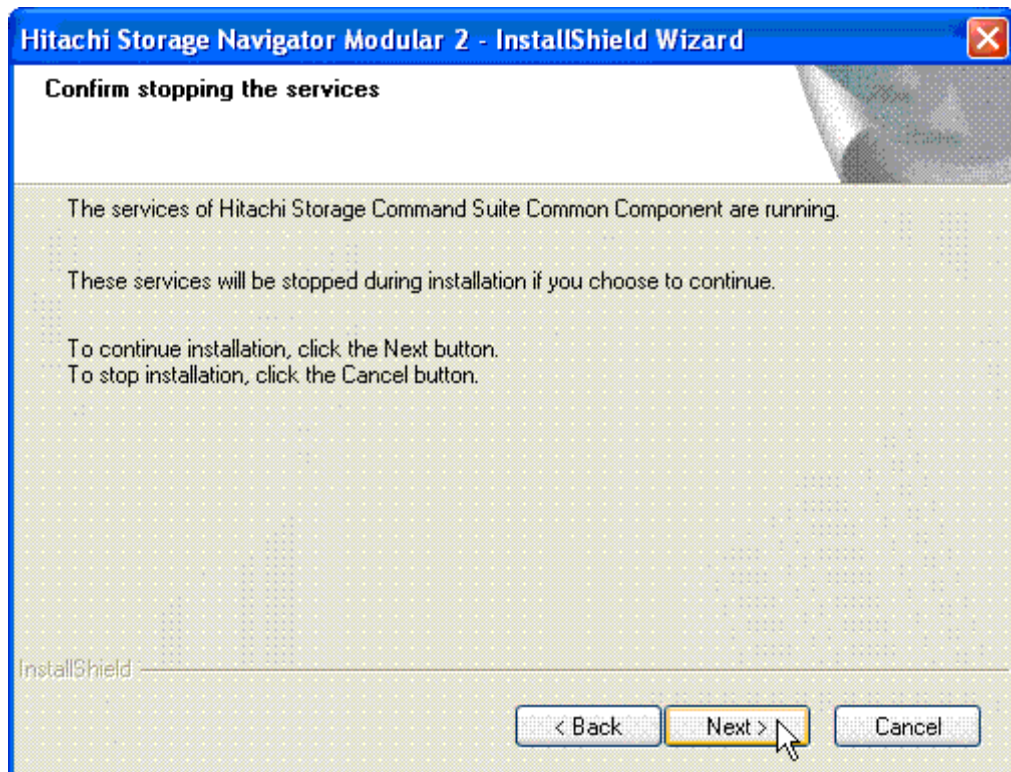

5. Click **Next**.

Clicking **Next** displays the **Confirm before uninstallation** dialog box appears.

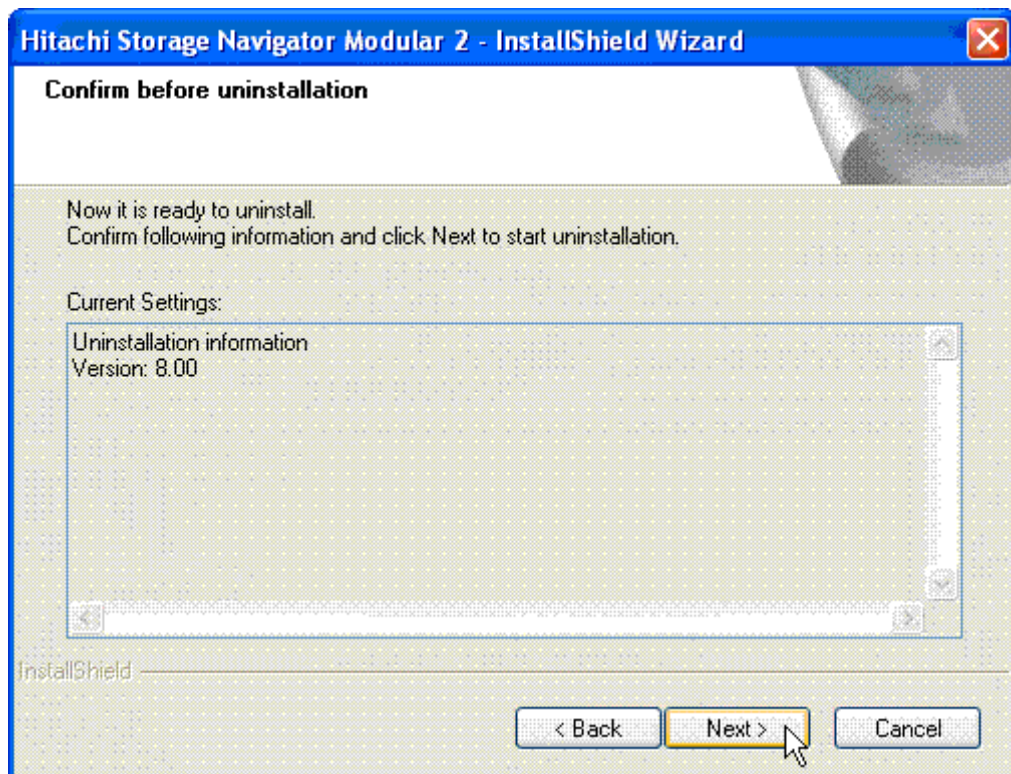

6. Click **Next**.

When un-installation is complete, the **Uninstall Complete** dialog box appears.

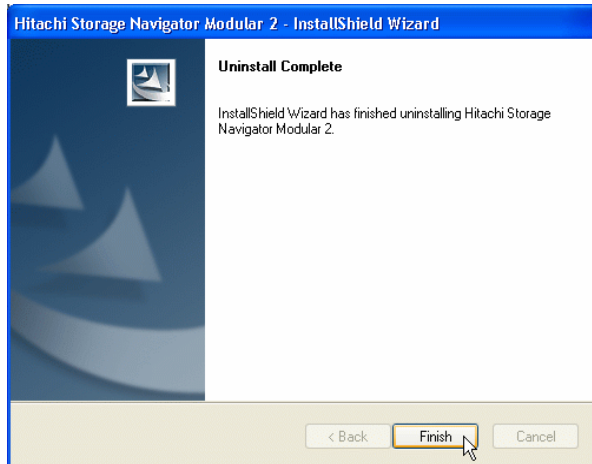

7. Click **Finish**.

When other applications using Hitachi Storage Command Suite Common Components have been installed, restart the services referring to the manual of each application.

To uninstall Hitachi Storage Navigator Modular 2 for Linux and Solaris:

1. When the application that uses Hitachi Storage Command Suite Common Components other than Hitachi Storage Navigator Modular 2 is installed, stop the daemon process of the Hitachi Storage Command Suite Common Components.
2. From the console, execute the following command.

```
/opt/HiCommand/StorageNavigatorModular/uninstall-hsnm2.sh
```



2

Getting Started

This chapter provides a function overview of Storage Navigator 2.

Functional Overview

Table 2.1 lists the available functions for Hitachi Storage Navigator Modular 2.

Refer to Help of Hitachi Storage Navigator Modular 2 for the description of the Web screen functions. This guide describes the functions of the Applet screen.

Refer to the manual of each priced option for the description of the priced option.

Table 2.1 Hitachi Storage Navigator Modular 2 Functions

Category	Function Name	Description	Notes	Online Usage
Components	Component status display	Displays the status of a component such as tray.		Yes
Groups	RAID Groups	RAID group: Creates, deletes, or displays a RAID group.	Only for AMS2000	Yes
		LU creation: Used to add a logical unit (LU). A new logical unit is added by specifying its capacity.		Yes
		LU deletion: Deletes the defined logical unit (LU). User data is deleted.		Yes
		LU formatting: Required to make a defined logical unit (LU) accessible by the host. Writes null data to the specified logical unit, and deletes user data.		Yes
	Host Groups	Review, operate, and set host groups.		Yes
	iSCSI Targets	Review, operate, and set iSCSI targets.		Yes
Settings	iSCSI Settings	View and configure iSCSI ports.		Yes
	FC Settings	View and configure FC ports.		Yes
	Replacement of Array	View and configure the array replacement.	Only for SMS	Yes
	Spare Drives	View, add, or remove spare drives.	Only for AMS2000	Yes
	Licenses	View, install, or de-install licensed storage features.		Yes
	Command Devices	View and configure command devices.		Yes
	DMLU	View and configure the Differential management Logical Units for replication/migration.	Only for AMS2000	Yes
	LAN	View and configure LAN.		Yes
	SATA Write & Compare	View and configure SATA Write & Compare.		Yes

Category	Function Name	Description	Notes	Online Usage
	Firmware	Refer/update firmware.	Array must be restarted to implement the settings.	Yes
	E-mail Alert	View and configure E-mail Alert function in the array.		Yes
	Date & Time	View and configure the Date & Time in the array.		Yes
	Advanced Settings	View and configure advanced settings.		Yes
Security	Secure LAN	Set the SSL certificate and validity/invalidity of the normal port.		Yes
Performance	Monitoring	View and output the monitored performance in the array.		Yes
	Tuning Parameter	Configure the parameter to performance in the array.		Yes
Alerts & Events	-	Displays the alerts and events.		Yes
Error Monitoring	Report when a failure occurs and controller status display	Polls the array and displays the status. If an error is detected, it is output into a log.	Contact your maintenance personal.	Yes

You can use the functions such as boot parameters and port options in the Applet screen. Refer to this manual for the contents of the functions.

Launching the Application

This chapter includes the following:

- Starting
- Operations
- Help
- Changing the Port Number and Connection Address
- Stopping and Starting the Services (Daemon Process)
- Automatic Log-off
- Setting the Server Certificate and Private Key
- Setting the Server Certificate and Private Key for Applet Screen of Navigator 2

Starting

Host side

1. Verify through **Control Panel** → **Administrative Tools** → **Services** whether **HBase Storage Mgmt Common Service**, **HBase Storage Mgmt Web Service**, and **SNM2 Server** have started.

Start the **HBase Storage Mgmt Common Service**, **HBase Storage Mgmt Web Service**, and **SNM2 Server** if they have not started.

Client side

For Windows:

When you use the JRE 1.6.0_10 or newer, setting the **Java Runtime Parameters** are not necessary in a client to start Navigator 2. When you use the JRE less than 1.6.0_10, setting the **Java Runtime Parameters** are necessary in a client to start Navigator 2.

1. In the Windows **Start** menu, choose **Settings, Control Panel**.
2. From the **Control Panel**, select the **Java**.
3. Click **View** of the upper position in the **Java** tab.
4. Enter "-Xmx192m" to the Java Runtime Parameters field.

It is necessary to set the Java Runtime Parameters to display the Applet screen.

5. Click **OK**.
6. Click **OK** in the **Java** tab.
7. Close the **Control Panel**.

For Linux and Solaris:

1. Run the Java Control Panel from XWindow terminal executing the <JRE installed directory>/bin/jcontrol.
2. Click **View** of the upper position in the **Java** tab.
3. Enter "-Xmx192m" to the Java Runtime Parameters field.

It is necessary to set the Java Runtime Parameters to display the Applet screen.

4. Click **OK**.
5. Click **OK** in the **Java** tab.

To start Navigator 2:

1. Activate the browser and specify the URL as follows.

Example: `http://#####:23015/StorageNavigatorModular/`

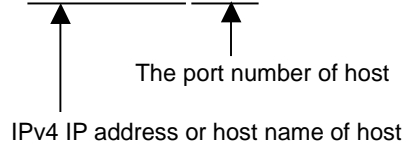

Example: `http://[#####]:23015/StorageNavigatorModular/`

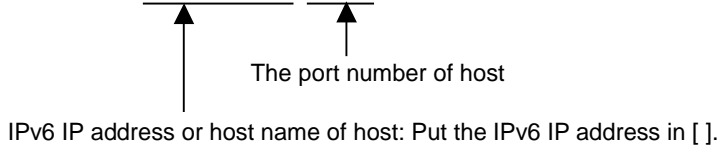

Example: `https://#####:23016/StorageNavigatorModular/`

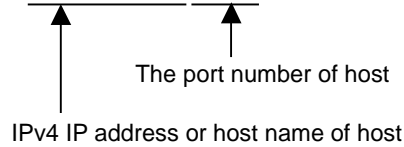

Example: `https://[#####]:23016/StorageNavigatorModular/`

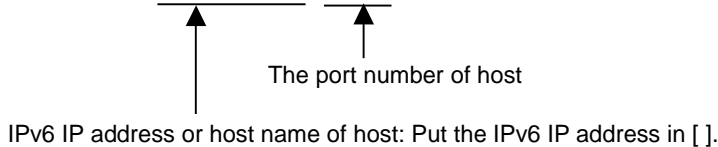

Note: The https is invalid in the status immediately after the installation. When connecting it with the https, it is required to set the server certificate and private key in advance referring to the section 0.

For the URL, specify a host name or IP address of Navigator 2. Do not specify a loop back address such as localhost and 127.0.0.1. When you specify a loop back address such as localhost or 127.0.0.1, the Web screen is displays, but the Applet screen is not displays.

The user login screen displays.



2. Enter your login information and click **Login**.

When logging in Navigator 2 for the first time after installing it newly, login with the built-in user's system account. The default password of the system account is **manager**. If another user is registered, login with the registered user. Enter the user ID and password, and click **Login**.

To prevent unauthorized access, we recommend changing the default password of the system account. You cannot delete the system account or change the authority of the system account. The system account is the built-in account common to the Hitachi Storage Command Suite products. The system account can use all the functions of Hitachi Storage Command Suite Common Component including Navigator 2 and access all the resources that each application manages. When Hitachi Storage Command Suite Common Component are already installed in the PC, etc. in which Navigator 2 is installed and the password of the system account is changed, login with the changed password.

Although you can login with the user ID registered in Hitachi Storage Command Suite Common Component, you cannot operate Navigator 2. Add the operation authority of Navigator 2 after logging in Navigator 2, and login again.

Navigator 2 starts and the Arrays screen displays.

3. Since the Arrays screen is displays, use Navigator 2 after registering the array unit in it.

Operations

Navigator 2 screens consist of the Web and Applet screens.

When you start Navigator 2, the login screen is displayed. When you login, the Web screen that shows the Arrays list is displayed. On the Web screen, operations provided by the screen and the dialog box is displayed. When you execute Advanced Settings on the Arrays screen and when you select the 9500V and AMS/WMS on the Web screen of the Arrays list, the Applet screen is displayed.

One user operates the Applet screen to run the 9500V and AMS/WMS, and two or more users cannot access it at the same time.

Figure 3.1 Arrays Screen and SMS100 Array Screens

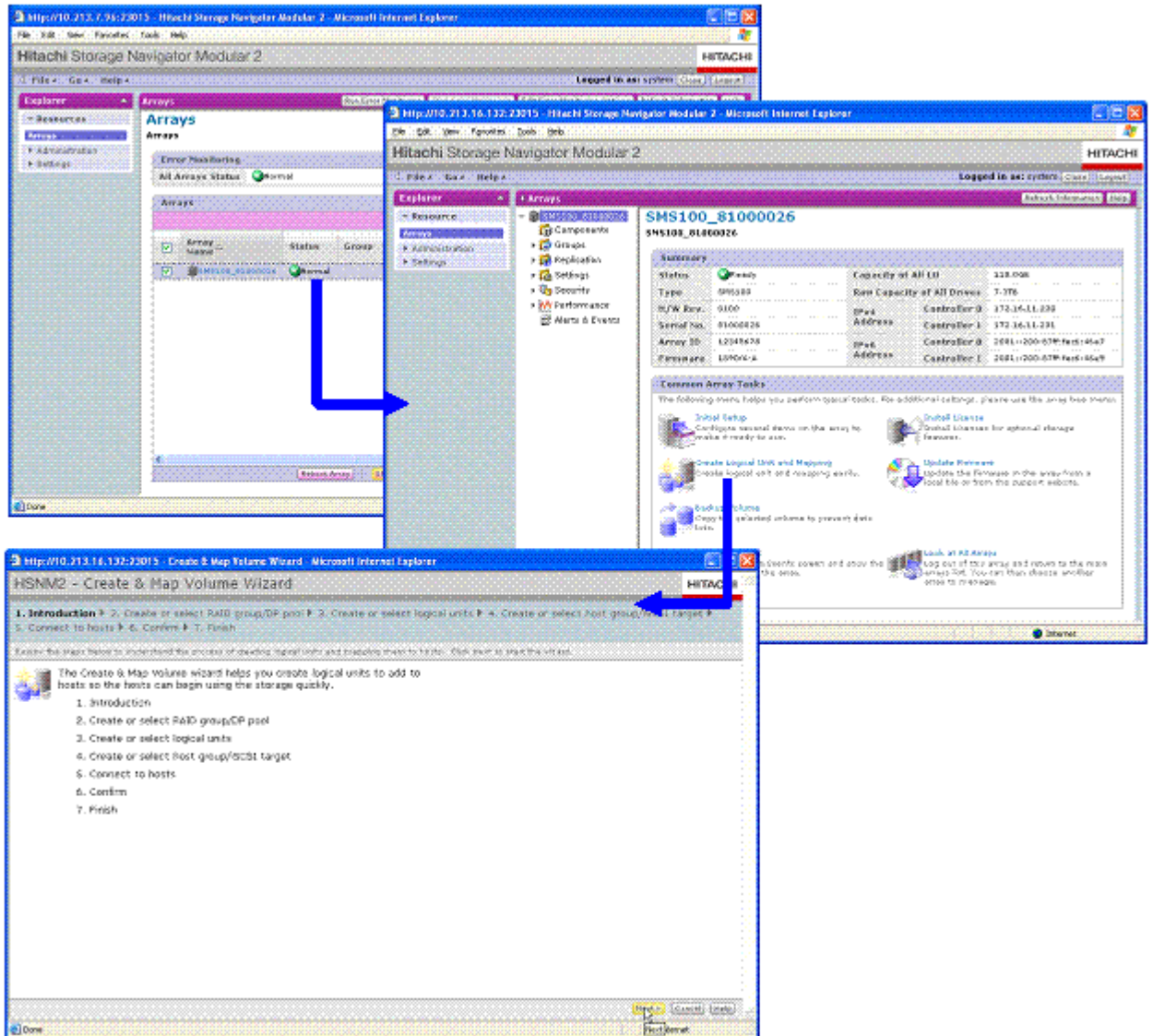
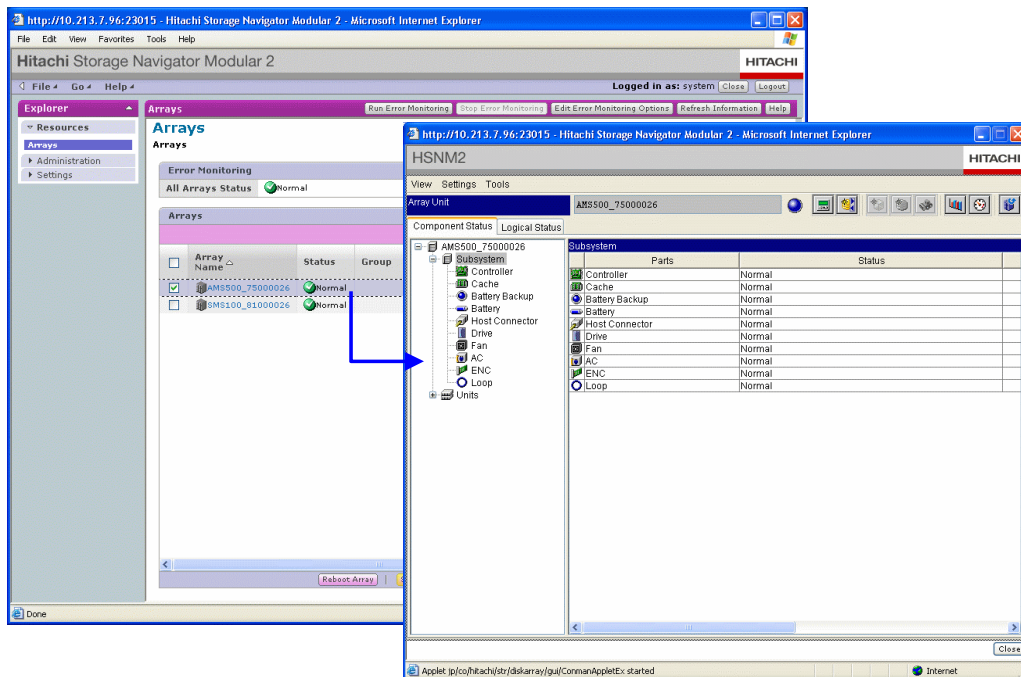

Figure 3.2 Applet Screen



Screens such as the Array screens displays when you login are Web screens. When you click the tree, details of the screen are updated on the same screen. When you click a button on the screen, a dialog box displays. Two types of dialog boxes exist; one is displayed on the Web screen and the other is displayed on the Applet screen.

A dialog box on the Web screen is displayed on the same screen by clicking any buttons. This is the same with the Applet screen. Use each function of the Web or Applet screen after completing the dialog function and closing the dialog box.

You can operate another button while the dialogue box is open. In that case, the display in the dialog box currently open is changed. However, the function of the dialog box that was open has worked.

Refer to Help for the procedure for operating the Web screen. The Help is not described in this manual. Since the Help for the procedure for operating the Applet screen is not provided, refer to this manual when you need help.



Note: The Applet screen is displayed connected to the **SNM2 Server**. If 20 minutes elapse while displaying the Applet screen, you will not be able to operate it due to the automatic logoff function. If the operation is completed, close the screen.

The following table shows the troubleshooting steps to take when the Applet screen does not display.

Problems	Case	Solution
The following message appears. DMEG800003: The error occurred in connecting RMI server. Please reboot the server.	The IP address of the server that installed Navigator 2 was changed.	Log out of Navigator 2, and change the IP address of "jp.co.hitachi.str.diskarray.rmi.hostname" of the "snmserver.properties" file in "StorageNavigatorModular\server" in the installation folder of Navigator 2. After that, restart the service. Then, log in Navigator 2. (See the section 0)
	The SNM2 server stopped.	Log out of Navigator 2, and then restart the service. Then, log in Navigator 2. (See the section 0)
	Other services using the port number 1099 exist.	Log out of Navigator 2, and change the port number of "jp.co.hitachi.str.diskarray.rmi.port" of the "snmserver.properties" file in "StorageNavigatorModular\server" in the installation folder of Navigator 2. After that, restart the service. Then, log in Navigator 2. (See the section 0) Or, change the port number of the service that is using the same port number.
	An IP address is not assigned to the server that installed Navigator 2.	Assign an IP address to the server. After that, restart the service. (See the section 0)
	It was not connectable although starting of Navigator 2 was specified by the host name.	Check if the host name is correct by the ping command. Or, start Navigator 2 by specifying an IP address instead of the host name.
	Two or more IP addresses are specified for the server that installed Navigator 2.	Log out of Navigator 2, and change the IP address to the other IP address of "jp.co.hitachi.str.diskarray.rmi.hostname" of the "snmserver.properties" file in "StorageNavigatorModular\server" in the installation folder of Navigator 2. After that, restart the service. Then, log in Navigator 2. (See the section 0) When Navigator 2 fails to start even if the IP address is changed, try other IP addresses.
The  appears in the Applet launch screen, and the following message appears. (Error) Click it and check the details.	127.0.0.1 or localhost is specified. The following exceptions are displayed in the Java console. java.security.AccessControlException	Log out of Navigator 2, and change "jp.co.hitachi.str.diskarray.rmi.hostname" of the "snmserver.properties" file in "StorageNavigatorModular\server" in the installation folder of Navigator 2 to an IP address of the actual server. After that, restart the service. Then, log in Navigator 2. (See the section 0)
	The Temporary Internet Files on the Java Control Panel is not deleted.	Open the Java Control Panel , and click Settings on of the General tab. Click Delete Files in the Temporary Files Settings dialog and delete the internet temporary files. Close all the opened browsers, and then start Navigator 2.

	The Temporary Internet Files on the Java Control Panel is set to Keep temporary files on my computer .	Open the Java Control Panel , and click Settings on of the General tab. Uncheck the checkbox of Keep temporary files on my computer in the Temporary Files Settings dialog. Close all the opened browsers, and then start Navigator 2.
The following message appears. Failed to connect with the web server. The setting of the certificate of the client is not correct, the server may be down, or an automatic logoff was executed. Confirm the execution environment, and then login again. (code: 0x000000000000b001)	Windows Firewall is not set correctly.	Off the Windows Firewall by the Window Firewall on the Control Panel . Or, add program "snm2srv.exe" of "StorageNavigatorModular\server\jre1.6.0\bin" in the installation folder of Navigator 2 as the Exceptions of the Windows Firewall .
The following message appears. DMEG800004: The error occurred in registering temporary user of RMI launch. Please reboot the server.	The server that installed Navigator 2 is standby or stopped.	Open the Power Options on the Control Panel , specify System standby of the Power Schemes tab to Never , and uncheck the checkbox of the Enable hibernation of the Hibernate tab.
The following message appears. DMEG000220: Cannot display because JRE is not installed or it is disabled. Please install the JRE or enable it and try again.	The Java Applet Runtime Settings is not Enabled .	Open the Java Control Panel , and click View of the Java Applet Runtime Settings of the Java tab. Check Enabled in the Java Runtime Settings screen.
	The Java Console is not Enabled .	Select the Tools from the browser menu, and click the Enable or Disable Add-ons from the Manage Add-ons . Select the Java(TM) Platform SE binary , and check Enabled if Disabled is checked.
The following message appears. DMEG0002F0: Since memories required for the Advanced Settings are insufficient, a screen cannot be displayed. Change a setup of Java Plug-in installed in the client and increase the usable memories.	Usable memory setting of Java does not specify -Xmx192m.	Open the Java Control Panel , and click View of the Java Applet Runtime Settings of the Java tab. Enter -Xmx192m in the Java Runtime parameter in the Java Runtime Settings screen. When installing the JRE Version 6 Update 10, the above-mentioned specification is not required. Therefore, we recommend you to update it.

Help

Navigator 2 describes the function of the Web screen with Help. Display Help by the following operation.

The following two ways exist for starting Help:

- Starting it from the **Help** menu in the Arrays screen
- Starting it with the **Help** button in the individual screen.

When starting the **Help** menu in the Arrays screen, the beginning of Help is displayed.

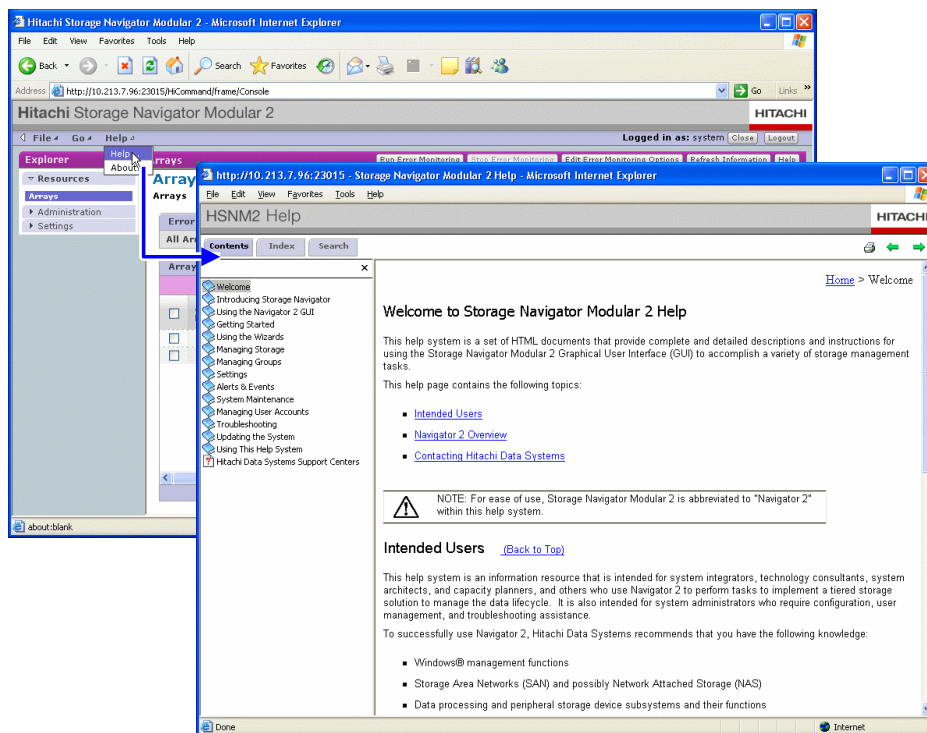

When starting it with the **Help** button in the individual screen, the description according to the function is displayed.

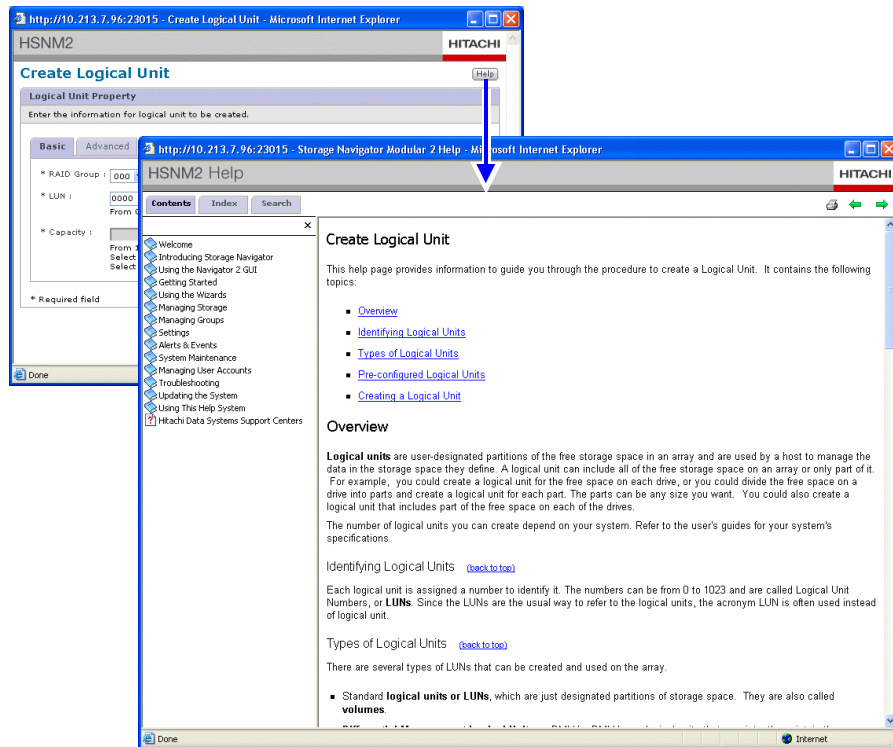

Changing the Port Number and Connection Address

Changing the Port Number for Starting Navigator 2

To change the port number you use for starting Navigator 2, operate it in the following procedure. For the default port number, 23015 is set.

1. Stop the **SNM2 Server** service (daemon process).
2. If there are other products to use Hitachi Storage Command Suite Common Components, stop the service (daemon process).
3. Stop the service (daemon process) for the Hitachi Storage Command Suite Common Components.
4. Edit setting file (httpsd.conf) and change the port number.

For Windows:

The listen in the C:\Program Files\HiCommand\Base\httpsd\conf\httpsd.conf file specifies the port number. Rewrite to a port number you want to change.

For Linux and Solaris:

The listen in the /opt/HiCommand/Base/httpsd/conf/httpsd.conf file specifies the port number. Rewrite to a port number you want to change.

Listen 23015

5. Start the service (daemon process) for the Hitachi Storage Command Suite Common Components.
6. Start the **SNM2 Server** service (daemon process).
7. If there are other products to use Hitachi Storage Command Suite Common Components, start the service (daemon process).



Note: If you change the port number used by Hitachi Storage Command Suite Common Components, all the installed products to use Hitachi Storage Command Suite Common Components are affected. When other products to use Hitachi Storage Command Suite Common Components are installed, check that the port number change does not cause problems for operating other products.

Changing the Port Number for Applet Screen of Navigator 2

When changing the port number used to display the Applet screen of Navigator 2, operate it in the following procedure. The number specified at the time of the installation is set for the default port number. The port number installed in default is 1099.

1. Stop the **SNM2 Server** service.
2. If there are other products to use Hitachi Storage Command Suite Common Components, stop the service (daemon process).
3. Stop the service (daemon process) for the Hitachi Storage Command Suite Common Components.
4. Edit two setting files (snm.conf and snmserver.properties) and change the port number. Set the same number for the two files. If the set number differs, the Applet screen will not be displayed.

For Windows:

The launch.port in the C:\Program Files\HiCommand\StorageNavigatorModular\conf\snm.conf file specifies the port number. Rewrite to a port number you want to change.

```
Launch.port=1099
```

The jp.co.Hitachi.strdiskarray.rmi.port in the C:\Program Files\HiCommand\StorageNavigatorModular\server\snmserver.properties file specifies the port number. Rewrite to a port number you want to change.

```
jp.co.Hitachi.strdiskarray.rmi.port=1099
```

For Linux and Solaris:

The launch.port in the /opt/HiCommand/StorageNavigatorModular/conf/snm.conf file specifies the port number. Rewrite to a port number you want to change.

```
Launch.port=1099
```

The jp.co.Hitachi.strdiskarray.rmi.port in the /opt/HiCommand\StorageNavigatorModular\server\snmserver.properties file specifies the port number. Rewrite to a port number you want to change.

```
jp.co.Hitachi.strdiskarray.rmi.port=1099
```

5. Start the service (daemon process) for the Hitachi Storage Command Suite Common Components.
6. Start the **SNM2 Server** service (daemon process).
7. If there are other products to use Hitachi Storage Command Suite Common Components, start the service (daemon process).

Changing the Connection Address for Applet Screen of Navigator 2

Make the change only when you want to change the IP address of the host in which Navigator 2 has been already installed. If you only change the connection address, the Applet screen will not be displayed.

To change the connection address used to display the Applet screen of Navigator 2, operate it in the following procedure. The address specified at the time of the installation is set for the default address. Specify the IP address or the host name of the installed host.

1. Stop the **SNM2 Server** service (daemon process).
2. If there are other products to use Hitachi Storage Command Suite Common Components, stop the service (daemon process).
3. Stop the service (daemon process) for the Hitachi Storage Command Suite Common Components.
4. Edit setting file (snmserver.properties) and change the connection address.

For Windows:

The `jp.co.Hitachi.strdiskarray.rmi.hostname` in the `C:\Program Files\HiCommand\StorageNavigatorModular\server\snmserver.properties` file specifies the connection address. Rewrite to a connection address you want to change.

For Linux and Solaris:

The `jp.co.Hitachi.strdiskarray.rmi.hostname` in the `/opt/HiCommand/StorageNavigatorModular/server/snmserver.properties` file specifies the connection address. Rewrite to a connection address you want to change.

```
jp.co.Hitachi.strdiskarray.rmi.hostname=192.168.0.1
```

5. Start the service (daemon process) for the Hitachi Storage Command Suite Common Components.
6. Start the **SNM2 Server** service (daemon process).
7. If there are other products to use Hitachi Storage Command Suite Common Components, start the service (daemon process).

Stopping and Starting the Services (Daemon Process)

If you install Navigator 2 in Windows, Hitachi Storage Command Suite Common Components and the **SNM2 Server** are registered in the OS as services. If you install Navigator 2 in Linux and Solaris, start and stop scripts of the process are created below /etc/init.d and the Hitachi Storage Command Suite Common Components and **SNM2 Server** are executed automatically as the daemon process when it starts.

Because the services (daemon process) are registered in the start status, if you start the OS, the services (daemon process) are automatically started. When a user performs the following operations, however, the user must stop, start, or restart the services (daemon process) of Hitachi Storage Command Suite Common Components and the **SNM2 Server**.

- Updating installation of Navigator 2
- Uninstalling of Navigator 2
- Installing other products to use Hitachi Storage Command Suite Common Components
- Uninstalling other products to use Hitachi Storage Command Suite Common Components
- Changing the setting files of Navigator 2
- When it is required to stop or start the service (daemon process) to use Hitachi Storage Command Suite Common Components while another product is in use

When the service (daemon process) is stopped, the functions of Navigator 2 and other products to use Hitachi Storage Command Suite Common Components become unable to be used. Check the following items before stopping the service (daemon process).

- All users must not be using Navigator 2.
- No problem occurs even if the error monitoring is temporarily invalidated.
- Update of the firmware must not be operated.
- No problem occurs even if services (daemon process) of other products to use Hitachi Storage Command Suite Common Components are stopped. (Refer to the manual of each product for the cautionary notes on stopping the services (daemon process) of other products.)

You can restart the services (daemon process) by continuing each operation to stop or start the services (daemon process).

Stopping the Services (Daemon Process)

To stop the services (daemon process):

1. Stop the **SNM2 Server** service (daemon process).
2. Stop the service (daemon process) for the Hitachi Storage Command Suite Common Components.

Among the above procedures, if other products to use Hitachi Storage Command Suite Common Components are installed, step 2, is not required for each product but it is executed only once. Besides, the operations other than the above may be required for each product when the services (daemon process) are stopped. Refer to the manual of each product for the details.

Stopping the SNM2 Server Service (Daemon Process)

For Windows:

To stop the **SNM2 Server** service, used the **Control Panel** or **Command Prompt** of Windows.

- Control Panel:
 1. In the Windows **Start** menu, choose **Settings, Control Panel**.
 2. From the **Control Panel**, select the **Administrative Tools**.
 3. Select the **Services**.
 4. From the **Services (Local)** list, select the **SNM2 Server**.
 5. Select the **Stop the service**.
- Command Prompt
 1. In the Windows **Start** menu, choose **Programs, Accessories**, and then **Command Prompt**.
 2. In the **Command Prompt**, specify as following command and then press the **Enter**.

```
C:\> net stop snm2server
```

Any directory can be the current directory at the time of the command execution.

For Linux and Solaris:

To stop the **SNM2 Server** daemon process, execute the following command.

```
/etc/init.d/snm2srv stop
```

The root authority is required to execute the command.
Any directory can be the current directory at the time of the command execution.

Stopping the Hitachi Storage Command Suite Common Components

For Windows:

To stop the Hitachi Storage Command Suite Common Components service, used the **Command Prompt** of Windows.

1. In the Windows **Start** menu, choose **Programs, Accessories**, and then **Command Prompt**.
2. The command prompt moves the current directory to the directory in which the commands of Hitachi Storage Command Suite Common Components have been installed.

```
C:> cd /D C:\Program Files\HiCommand\Base\bin
```

3. The directory in which the commands of Hitachi Storage Command Suite Common Components have been installed, specify as following command and then press the **Enter**.

```
C:\Program Files\HiCommand\Base\bin>hcmdssrv /stop
```

4. It may take several seconds to several minutes to stop the service. Check that the service is stopped by executing the following command.

```
C:\Program Files\HiCommand\Base\bin>hcmdssrv /status
```

The underlined part of the command, C:\Program Files\HiCommand, is a path of the folder in which Hitachi Storage Command Base Common Components is installed. It is required to replace it according to the environment in which Hitachi Storage Command Base Common Components is installed. In the environment not using the products to use Hitachi Storage Command Suite Common Components other than Navigator 2, this folder is the same as that in which Navigator 2 has been installed. If other products are also installed, specify a folder that was specified when the first product was installed.



Note: Do not directly stop the service of Hitachi Storage Command Suite Common Components using the **Services** screen of the **Control Panel** or the `net stop` command. If you stop it directly, Hitachi Storage Command Suite Common Components may become unable to be used.

For Linux and Solaris:

To stop the Hitachi Storage Command Suite Common Components daemon process, execute the following command.

```
/opt/HiCommand/Base/bin/hcmdssrv -stop
```

The root authority is required to execute the command. Any directory can be the current directory at the time of the command execution.

It may take several seconds to several minutes to stop the daemon process. Check that the daemon process is stopped by executing the following command.

```
/opt/HiCommand/Base/bin/hcmdssrv -status
```

The underlined part of the command, /opt/HiCommand, is a path of the directory in which Hitachi Storage Command Base Common Components is installed. For Linux, it is required to replace it according to the environment in which Hitachi Storage Command Base Common Components is installed. In the environment not using the products to use Hitachi Storage Command Suite Common Components other than Navigator 2, this directory is /opt/HiCommand. If other products are also installed, specify a directory that was specified when the first product was installed. Refer to the manual of each product for the details.

For Solaris, it is not required to replace /opt/HiCommand.



Note: In the process of the Hitachi Storage Command Suite Common Components, do not stop it by using the script below /etc/init.d or by sending a signal with the kill command, etc. If you stop it in such method, you may not use the Hitachi Storage Command Suite Common Components.

Starting the Services (Daemon Process)

To start the services (daemon process):

1. Start the service (daemon process) for the Hitachi Storage Command Suite Common Components.
2. Start the **SNM2 Server** service (daemon process).

Among the above procedures, if other products to use Hitachi Storage Command Suite Common Components are installed, step 1, is not required for each product but it is executed only once. Besides, the operations other than the above may be required for each product when the services (daemon process) are stopped. Refer to the manual of each product for the details.

Starting the Command Suite Common Components

For Windows:

To start the Hitachi Storage Command Suite Common Components service, used the **Command Prompt** of Windows.

1. In the Windows **Start** menu, choose **Programs, Accessories**, and then **Command Prompt**.
2. The command prompt moves the current directory to the directory in which the commands of Hitachi Storage Command Suite Common Components have been installed.

```
C:\> cd /D C:\Program Files\HiCommand\Base\bin
```

3. The directory in which the commands of Hitachi Storage Command Suite Common Components have been installed, specify as following command and then press the **Enter**.

```
C:\Program Files\HiCommand\Base\bin>hcmdssrv /start
```

4. It may take several seconds to several minutes to start the service. Check that the service is started by executing the following command.

```
C:\Program Files\HiCommand\Base\bin>hcmdssrv /status
```

The underlined part of the command, C:\Program Files\HiCommand, is a path of the folder in which Hitachi Storage Command Base Common Components is installed. It is required to replace it according to the environment in which Hitachi Storage Command Base Common Components is installed.



Note: Do not directly start the service of Hitachi Storage Command Suite Common Components using the **Services** screen of the **Control Panel** or the `net start` command. If you start it directly, Hitachi Storage Command Suite Common Components may become unable to be used.

For Linux and Solaris:

To start the Hitachi Storage Command Suite Common Components daemon process, execute the following command.

```
/opt/HiCommand/Base/bin/hcmdssrv -start
```

The root authority is required to execute the command. Any directory can be the current directory at the time of the command execution.

It may take several seconds to several minutes to start the daemon process. Check that the daemon process is stopped by executing the following command.

```
/opt/HiCommand/Base/bin/hcmdssrv -status
```

The underlined part of the command, /opt/HiCommand, is a path of the directory in which Hitachi Storage Command Base Common Components is installed. For Linux, it is required to replace it according to the environment in which Hitachi Storage Command Base Common Components is installed. In the environment not using the products to use Hitachi Storage Command Suite Common Components other than Navigator 2, this directory is /opt/HiCommand. If other products are also installed, specify a directory that was specified when the first product was installed. Refer to the manual of each product for the details.

For Solaris, it is not required to replace /opt/HiCommand.



Note: In the process of the Hitachi Storage Command Suite Common Components, do not start it by using the script below /etc/init.d or by sending a signal with the `kill` command, etc. If you stop it in such method, you may not use the Hitachi Storage Command Suite Common Components.

Starting the SNM2 Server Service (Daemon Process)

For Windows:

To start the **SNM2 Server** service, used the **Control Panel** or **Command Prompt** of Windows.

- Control Panel:
 1. In the Windows **Start** menu, choose **Settings, Control Panel**.
 2. From the **Control Panel**, select the **Administrative Tools**.
 3. Select the **Services**.
 4. From the **Services (Local)** list, select the **SNM2 Server**.
 5. Select the **Restart the service**.
- Command Prompt

1. In the Windows **Start** menu, choose **Programs, Accessories**, and then **Command Prompt**.
2. In the **Command Prompt**, specify as following command and then press the **Enter**.

```
C:\> net start snm2server
```

Any directory can be the current directory at the time of the command execution.

For Linux and Solaris:

To start the **SNM2 Server** daemon process, execute the following command.

```
/etc/init.d/snm2srv start
```

The root authority is required to execute the command.
Any directory can be the current directory at the time of the command execution.

Automatic Log-off

When you do not operate anything for 20 minutes or longer while displaying the Applet screen of Navigator 2, a logoff is done automatically by the **SNM2 Server** and you will not be able to operate it on the Applet screen. However, you may continue to operate it on the Web screen.

Access to a host by Navigator 2 occurs when the configuration information is set. It does not occur in a change of the displayed information such as a tab switching on the Applet screen.

When the automatic logoff runs, a message is displayed in response to the operation informing that the connection to the host is impossible. When the message is displayed, return to the Array screen, select the Array again, and display the Array screen.

Setting the Server Certificate and Private Key

We recommend that you use the server certificate and private key for SSL communication that you have created for using the array safely in your environment. The methods to create and set the server certificate and private key using OpenSSL are shown here.

1. Stop the services for Navigator 2.

Stop the service of the **SNM2 Server** first and then stop the service of Hitachi Storage Command Suite Common Components. For more details, see the section 0.

2. Create a private key.

Create a private key using the `hcmdssslc` command.

Open the command prompt (terminal console for Unix) and move to the following directory.

For Windows: <Navigator 2 installation directory>\Base\bin

For Unix: <Navigator 2 installation directory>/Base/httpsd/ssl/bin

Execute the following command line. The underlined part indicates a bit length of the key. Enter any of 2048 and 3072.

You must create the directory that to be output a private key in advance.

For Windows:

```
hcmdssslc genrsa -out c:\ca\httpsdkey.pem <a bit length of the key>
```

For Unix:

```
sslc genrsa -out /ca/httpsdkey.pem <a bit length of the key>
```

An execution example is shown below:

```
hcmdssslc genrsa -out c:\ca\httpsdkey.pem 2048
Loading 'entropy' into random state - unable to load 'random state'
warning, not much extra random data, consider using the -rand option
Generating 2 prime RSA private key, 2048 bit long modulus
.....+++++
.....+++++
e is 65537 (0x10001)
```

3. Create a Certificate Signing Request (CSR).

To create a CSR, execute the following command line.

For Windows:

```
hcmdssslc req -config "C:\Program Files\HiCommand\Base\httpsd\ssl\bin\demoCA\ssl.cnf"
-new -key c:\ca\httpsdkey.pem -out c:\ca\httpsd.csr
```

For Unix:

```
./ssl.cnf req -config /opt/HiCommand/Base/httpsd/ssl/bin/demoCA/ssl.cnf
-new -key ca/httpsdkey.pem -out /ca/httpsd.csr
```

An execution example is shown below:

```

Using configuration from C:\Program Files\HiCommand\Base\httpsd\ssl\bin\demoCA\
ssl.cnf
You will be prompted to enter information to incorporate
into the certificate request.
This information is called a Distinguished Name or a DN.
There are many fields however some can remain blank.
Some fields have default values.
Enter '.', to leave the field blank.
-----
Country Name (2 letter code) []:us
State or Province Name (full name) []:California
Locality Name (eg, city) []:San Jose
Organization Name (eg, company) []:Hitachi
Organizational Unit Name (eg, section) []:Hitachi
Common Name (eg, YOUR name) []:Hitachi
Email Address []:

Please enter the following 'extra' attributes
to be sent with your certificate request
A challenge password []:
An optional company name []:

```

Submit the created csr file ("httpsd.csr" in the above example) to the CA (Certificate Authority) and obtain the signed certificate.

Even if you do not submit the csr file or obtain the signed certificate file from the CA, you can correspond to SSL by creating the certificate file with your signature using the `hcmdssl` (`ssl` for Unix) command. In this case, however, the warning screen is displayed at the time of the initial screen display of Navigator 2, and when the applet launches.

To create a self-signed certificate file, using the `hcmdssl` (`ssl` for Unix) command. Execute the following command line.

For Windows:

```

hcmdssl x509 -in c:\ca\httpsd.csr -out c:\ca\newcert.pem -reg -signkey
c:\ca\httpsdkey.pem -days 365

c:\ca\httpsd.csr: CSR to CA
c:\ca\newcert.pem: self-signed certificate
c:\ca\httpsdkey.pem: key file

```

For Unix:

```

./ssl x509 -in /ca/httpsd.csr -out /ca/newcert.pem -reg -signkey
/ca/httpsdkey.pem -days 365

```

4. Edit the httpsd.conf file.

Open the httpsd.conf file stored in <installation directory>\Base\httpsd\conf with the text editor and edit it.

Remove "#" of the following underlined lines which are commented out by default and change the values of "SSLCertificateFile" and "SSLCertificateKeyFile".

Specify the signed certificate file obtained from the CA for "SSLCertificateFile" and the full path of the private key file created in step 2 for "SSLCertificateKeyFile".

The contents of the file are shown below:

```
SSLSessionCacheSize 0
#Listen 23016
#Listen [::]:23016
#<VirtualHost slj-orca2xp:23016>
#   ServerName slj-orca2xp
#   SSLEnable
#   SSLProtocol SSLv3 TLSv1
#   SSLRequireSSL
#   SSLCertificateFile "C:/ca/httpsd.pem"
#   SSLCertificateKeyFile "C:/ca/httpsdkey.pem"
#   SSLCACertificateFile "C:/Program
#Files/HiCommand/Base/httpsd/conf/ssl/cacert/anycert.pem"
#   SSLSessionCacheTimeout 3600
#</VirtualHost>
```

5. Start the services for Navigator 2.

Start the service of the **SNM2 Server** first and then start the service of Hitachi Storage Command Suite Common Components. For more details, see the section 0.

Setting the Server Certificate and Private Key for Applet Screen of Navigator 2

We recommend that you use the server certificate and private key for SSL communication that you have created for using the array safely in your environment. The methods to create and set the server certificate and private key using OpenSSL are shown here.

The setting is not required if you do not display the applet screen for operating the **Advanced Settings**.

The applet screen can only connect either the normal port or secure port.

1. Execute the setting tool.

Open the command prompt (terminal console for Unix) and move to the following directory.

For Windows:

<Navigator 2 installation directory>\StorageNavigatorModular\bin

For Unix:

<Navigator 2 installation directory>/StorageNavigatorModular/bin

Execute the following command.

For Windows: snmkey.bat

For Unix: ./snmkey.sh

An execution example is shown below: The shading parts are the input information.

```
cd "C:\Program Files\HiCommand\StorageNavigatorModular\bin"
c:
snmkey.bat

Keystore file or certification file are already existed.
If you set the secure port as use, the files are overwritten.
Are you sure you want to continue? (y/n) [n]:y
```

2. When you created the keystore file and the certification file for a client installation already, enter **y** on the above screen.

```
These settings need to stop the HiCommand Suite Common Component services and the RMI server service.
Do you want to continue processing? (y/n) [n]:y
Stopping the HiCommand Suite Common Component services...success
Stopping the RMI server service...success
```

3. When the Hitachi Storage Command Suite Common Components services or the RMI server service being was starting, the above message appears. Enter **y** on the above screen.

```
Current RMI normal port number:1099
Input the normal port number(Input "unset" to unset) [1099]:unset
```

4. Enter the port number that you want to set the normal port.
If you enter the **unset**, the normal port is not available.

```
Current RMI secure port number:unset
Input the secure port number(Input "unset" to unset) [unset]:10995
```

5. Enter the port number that you want to set the secure port.
If you enter the **unset**, the secure port is not available.



Note: You cannot be set the same port number to the normal and secure port number.

```
Input the alias name of keystore file [snm2rmi]:mysnm2rmi

Input the new password of keystore file:abcdefg

Creating keystore...success
Signing to keystore...success
Creating certification file...success
Updating certification file...success

RMI security settings have been set successfully.

Certification file have been output to the following path.
<C:\Program Files\HiCommand\StorageNavigatorModular\security\snm2rmi.cert>
```

6. Input the alias name and password of the keystore file for using SSL.
When the processing ended successfully, the created certification file path for a client is displays (the above underline).

```
Starting the RMI server service...success
Starting the HiCommand Suite Common Component services...success

All process completed.
```

When the processing ended successfully, the Hitachi Storage Command Suite Common Components services and RMI server service are starting automatically, and the command prompt (terminal console for Unix) screen is closed.

Execute the installation of the client side in the following procedure:

To be used the created certificate file for a client that you created the step 2 above. When a client and server are different, copy it to a client.

Open the command prompt (terminal console for Unix) and move to the following directory.

<JRE >installation directory>\bin

Execute the following command line. The underlined part is an item that the user can enter as an option.

```
keytool -import
-keystore "<JRE installation directory>\lib\security\cacerts"
-alias <alias name>
-file <created certificate file for a client>
```

An execution example is shown below:

```
keytool -import
-keystore "C:\Program Files\Java\server\jre1.6.0_07\lib\security\cacerts"
-alias snm2rmi -file "C:\cert\snm2rmi.cert"

Enter keystore password: changeit
Owner: CN=Hitachi, OU=Hitachi, O=Hitachi, L=San Jose, ST=California, C=us
Issuer: CN=Hitachi, OU=Hitachi, O=Hitachi, L=San Jose, ST=California, C=us
Serial number: 47b429aa
Valid from: Thu Feb 14 20:44:42 PDT 2008 until: Wed May 14 20:44:42 PDT 2008
Certificate fingerprints:
    MD5: D8:C3:CC:59:93:68:DA:68:8A:6F:0A:87:78:E8:74:32
    SHA1: C4:2D:49:2E:1E:AF:CC:AF:F5:1D:B2:A3:1C:44:DE:90:72:32:67:13
Trust this certificate? [no]: yes
Certificate was added to keystore
```

Enter **changeit** for the password.

Advanced Settings

This chapter describes how to start and configure advanced settings using Navigator 2.

This chapter includes the following:

- Starting the Advanced Settings
- Configuration Settings
- Access Mode
- Mapping Guard
- Parity Correction

Starting the Advanced Settings

1. Start Navigator 2.
2. Log in as registered user to Navigator 2.
3. Select an Array Unit in which you will set up advanced settings.
4. Click **Show & Configure Array**.
5. Select **Advanced Settings** icon in the **Settings** tree view.
6. Click **Open Advanced Settings**.

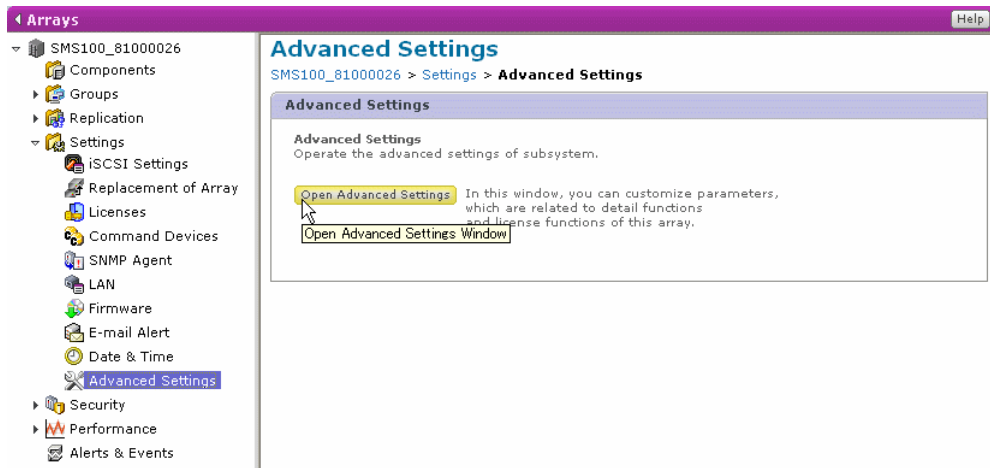

After a few minutes, an **Array Unit** (Applet) screen displays.



Note: The Applet screen is displayed connected to the **SNM2 Server**. If 20 minutes elapses while displaying the Applet screen, you will not be able to operate it due to the automatic logoff function. If the operation is completed, close the screen. If the Applet screen cannot be displayed, the login to the **SNM2 Server** may have failed. In this case, the Applet screen cannot be displayed again. The code: 0x000000000000b045 or "DMEG800003: The error occurred in connecting RMI server." is displayed on the Applet screen. Take the following actions.

- Close the Web browser, stop the **SNM2 Server** once, restart it, and display the screen of the Array you want to operate.
- Close the Web browser; confirm the **SNM2 Server** is started. If it has stopped, start it and display the screen of the Array that you want to operate.
- Return to the Array screen after 20 minutes elapsed and display the screen of the Array you want to operate.

Figure 4.1 Array Unit Screen

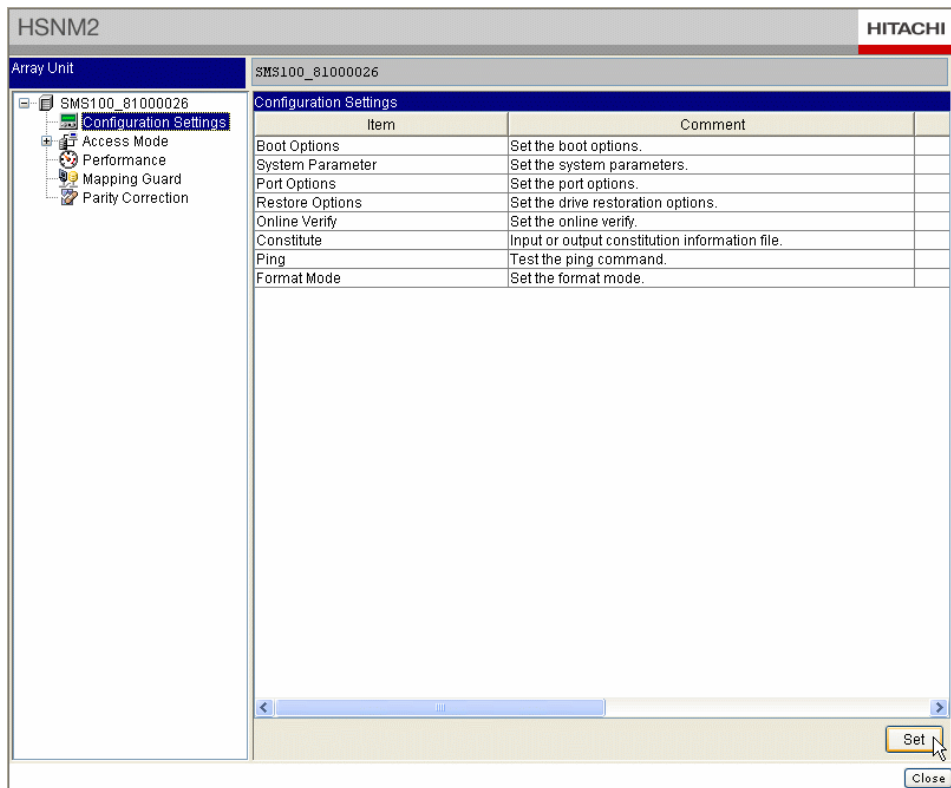

Configuration Settings

1. Select **Configuration Settings** icon in an **Array Unit** tree view.
2. Click **Set**.

The **Configuration Settings** tab page is displays.

The screenshot shows a Java Applet Window titled "Configuration Settings" for Array Unit SA800_81000026. It features several tabs: "Boot Options", "System Parameter", "Port Options", "Restore Options", "Online Verify", "Constitute", "Ping", and "Format Mode". The "System Startup Attribute" section has two radio buttons: "Single Mode" and "Dual Active Mode", with "Dual Active Mode" selected. Below this, there is a text input field for "Delay Planned Shutdown" set to "0" with a "min." label. Further down are text input fields for "Vendor ID" (containing "HITACHI"), "Product ID" (containing "DF600F"), "ROM Microprogram Version", and "RAM Microprogram Version". At the bottom right, there are "Apply" and "Reset" buttons, and at the bottom center, a "Close" button. The text "Java Applet Window" is visible at the bottom left of the window.

Boot Options

When the boot option is set, the subsystem requires a restart after setting changes.

Warning: Rebooting requires stopping I/O from the host.

To set the boot options:

1. Select or enter the following boot options.
 - **System Startup Attribute:** Select the subsystem configuration.
 - Single Mode:** Single configuration
 - Dual Active Mode:** Dual active configuration
 - **Delay Planned Shutdown:** Specify the time in minutes to delay the execution of the planned shutdown when the main switch has turned off. The applicable range is from 0 to 60 minutes.

- **Vendor ID:** Enter an eight-character vendor name. When the name consists of less than eight characters, make an eight-character entry by filling the reset with space(s). The default value set in HITACHI△. (△ Denotes a space.)
- **Product ID:** Enter a 16-character model name. When the name consists of less than 16 characters, make a 16-character entry by filling the reset with space(s). The default value set in DF600F△△△△△△△△△△. (△ Denotes a space.)
- **ROM Microprogram Version:** Specify a microprogram version of a ROM reported by inquiry command.
- **RAM Microprogram Version:** Specify a microprogram version of a RAM reported by inquiry command.

2. Click **Apply**.

3. Follow the information in messages that appear. Click **OK** to continue.

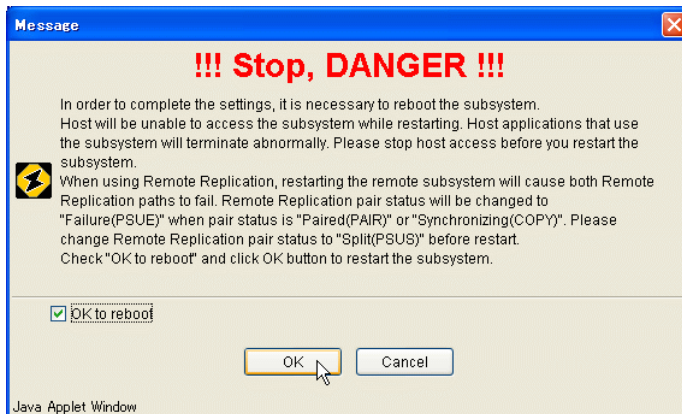
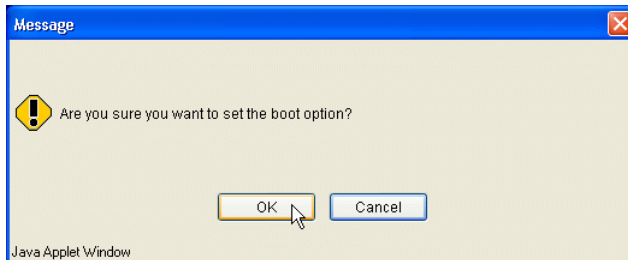

When you choose to restart the subsystem, the time the restart began is displayed. This usually takes approximately four to fifteen minutes.

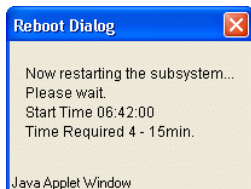

Note:



Note: It may take time for the subsystem to respond, depending on the condition of the subsystem. If it does not respond after 15 minutes or more, check the condition of the subsystem.

4. A message appears, stating that the restart is successful. Click **OK**.

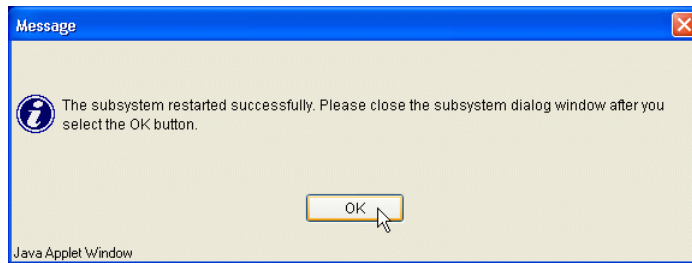

5. A message appears, click **Close**.

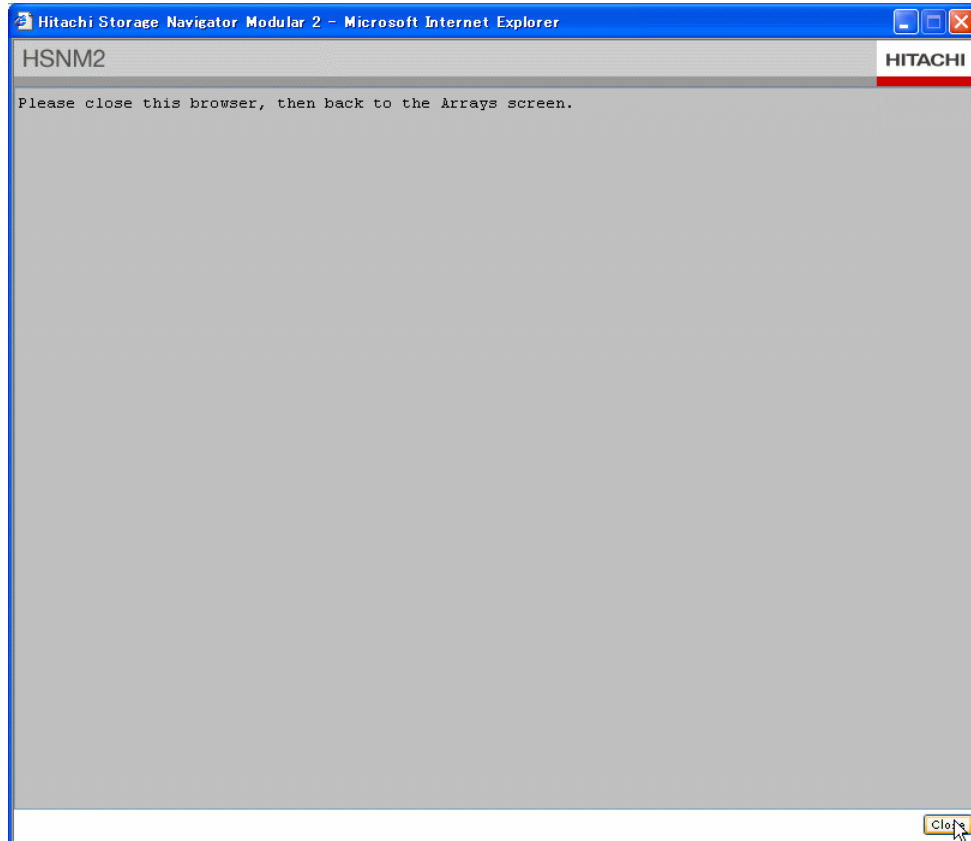

System Parameter

This setting information becomes valid without restarting the subsystem.

1. Click **Open Advanced Settings**.
After a few minutes, an **Array Unit** screen displays.
2. Select **Configuration Settings** icon in an **Array Unit** tree view.
3. Click **Set**.
4. Click the **System Parameter** tab.

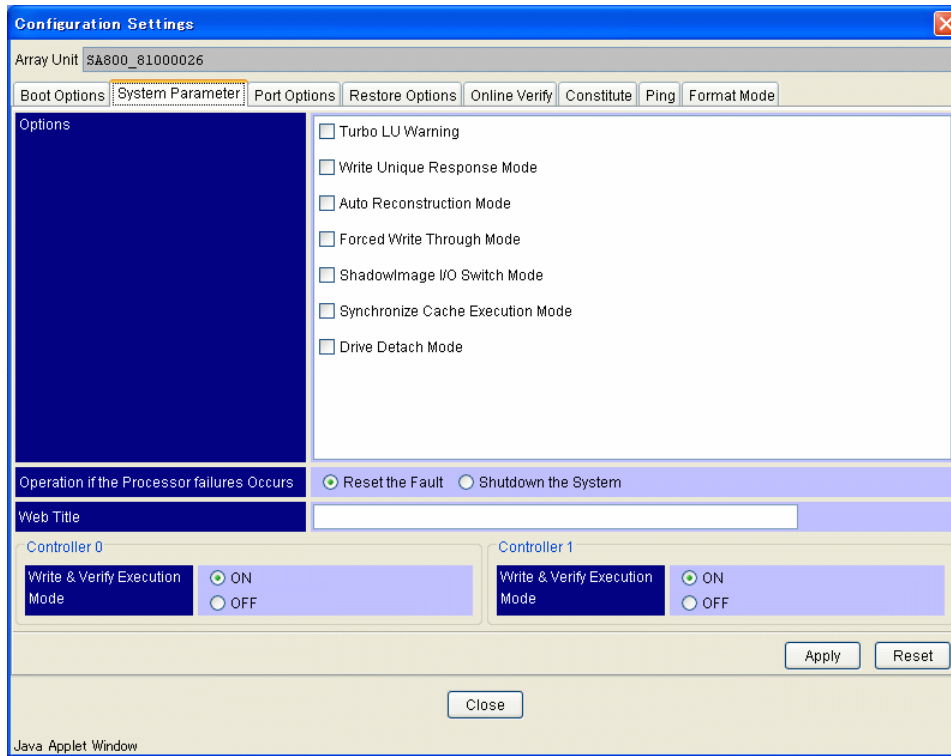

5. Set the system parameters. See Table 4.1 for a description of these parameters.
6. Click **Apply**.
7. Follow the information in messages that appear. Click **OK** to continue.

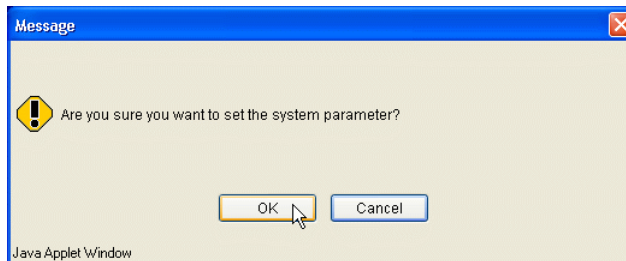

Table 4.1 Setting System Parameters

Parameter	Description	Operation
Turbo LU Warning	This parameter is to be specified when the Turbo LU setting function is used. Default = Disable	Disable: When the Turbo LU can no longer be maintained due to a failure, the parameter allows host access to be issued. Enable: When the Turbo LU can no longer be maintained due to a failure and the performance is lowered, the parameter suppresses host access and issues a warning.
Write Unique Response Mode	This parameter is to be specified when a host of the NX series is connected. Default = Disable	Disable: Cache memory is used for write commands. Enable: Write commands are executed unconditionally in write-through mode (write data directly to disk without using cache).
Auto Reconstruction Mode	This parameter specifies operations to be performed when a disk drive is removed. Default = Disable	Disable: When a disk drive is removed, correction copy to a spare disk drive is not performed. Enable: When a disk drive is removed, correction copy to a spare disk drive is performed. Caution: This mode is for test purposes and should only be used by authorized service personnel.
Forced Write Through Mode	This parameter specifies the method for executing write commands after a CTL detachment or power failure. Default = Disable	Disable: If a CTL detachment or power failure has occurred, cache memory is used for write commands. Enable: If a CTL detachment or power failure has occurred, write commands are executed in write-through mode (write data directly to disk without using cache).
ShadowImage I/O Switch Mode	This parameter specifies an operation of a ShadowImage P-VOL to be performed when a double disk drive failure occurs. Default = Disable	Disable: If a double failure occurs in disk drives of a ShadowImage P-VOL in the PAIR status, the status is changed to PSUE. Enable: If a double failure occurs in disk drives of a ShadowImage P-VOL in the PAIR status, the execution of the host I/O is switched to the S-VOL to continue the execution. Note: For further information, see the ShadowImage User's Guide.
Synchronize Cache Execution Mode	This parameter specifies an operation to be performed when the Synchronize Cache command is received.	Disable: No operation is performed when the Synchronize Cache command is received. Enable: When the Synchronize Cache command is received, all data in the cache memory is written to disk drives. Note: For further information, see the TrueCopy User's Guide.

Parameter	Description	Operation
Drive Detach Mode	Specifies an operation to be performed when a drive failure occurs in the same RAID group. Default = Disable	Disable: When a failure occurs in a disk drive in a state in which another disk drive in the same RAID group has already been detached due to a failure, the parameter does not detach the disk drive that failed secondarily. Enable: When a failure occurs in a disk drive in a state in which another disk drive in the same RAID group has already been detached due to a failure, the parameter detaches the disk drive that failed secondarily and detaches LUs (makes LUs unformatted) in the RAID group concerned.
Operation if the Processor failures Occurs	This parameter specifies the operation to be performed when a processor failure occurs. Default = Reset the Fault	Reset the Fault: The parameter resets. Shutdown System: The parameter shuts the subsystem down.
Web Title	When the Web function built in the subsystem is displayed with the browser, this parameter specifies characters to be displayed in the browser title bar. Default = Not set	Characters that can be entered (maximum 32) are alphabetic characters, numerals, and characters other than numerals (excluding ', ", and \).
Write & Verify Execution Mode	This parameter specifies the execution mode for write and verify operation. Default = OFF	ON: The write and verify operation is performed. OFF: The write and verify operation is not performed.

Port Options

The **Port Options** tab allows you to set the system parameter port options. The setting information becomes valid without restarting the subsystem.

1. Click **Open Advanced Settings**.
After a few minutes, an **Array Unit** screen displays.
2. Select **Configuration Settings** icon in an **Array Unit** tree view.
3. Click **Set**.
The **Configuration Settings** tab page is displays.
4. Click the **Port Options** tab.

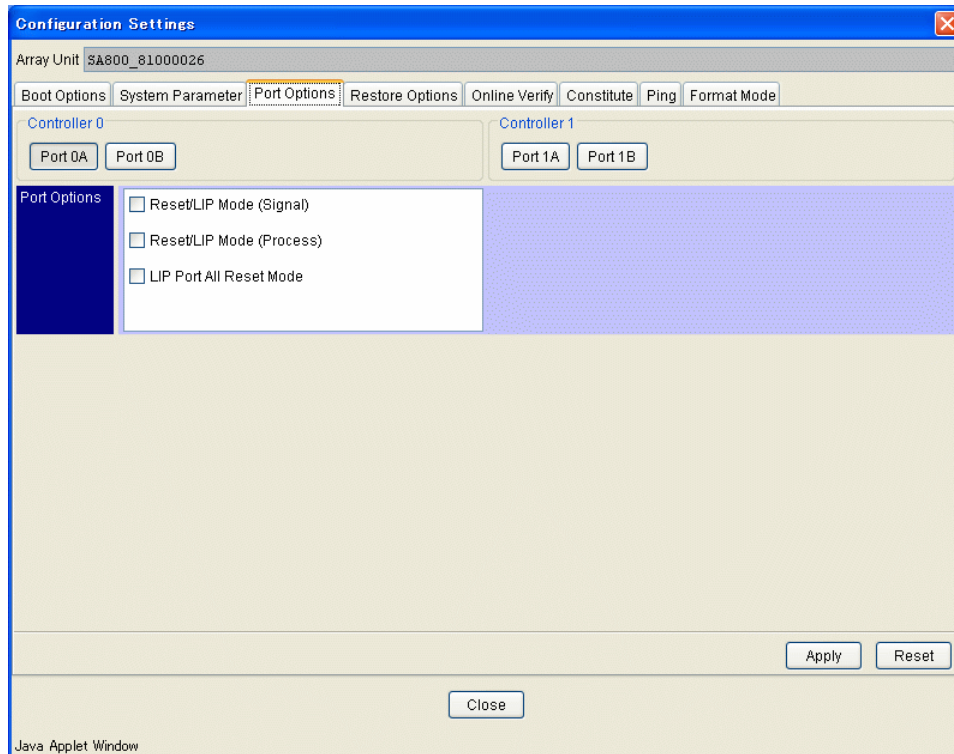

5. Select the desired port, and then select the desired **Port Options**:
 - **Reset/LIP Mode (Signal)**: Set this option to transmit Reset/LIP signals to other ports.
 - **Reset/LIP Mode (Process)**: Set this option to transmit reset processing to other ports. If this option is set, the **Reset/LIP Mode (signal)** is automatically enabled.
 - **LIP Port ALL Reset Mode**: Set this option to execute reset on receiving LIP.



Note: Multiple **Port Options** can be set, but depending on the setting, it may not function properly. If it is to be set, please refer to the appended subsystem manual and set only the applicable parameters.

6. Click **Apply**.
7. When the confirmation message displays, click **OK**.

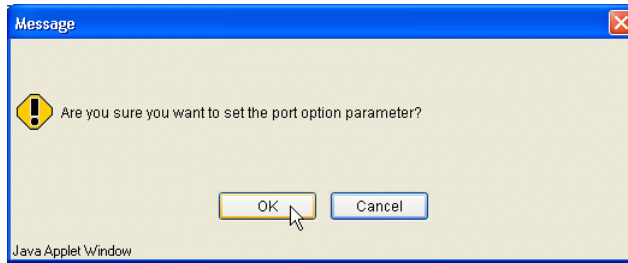

Restore Options

Do not set drive restoration options while a drive restoration is in progress.

To set drive restoration options:

1. Click **Restore Options** tab.

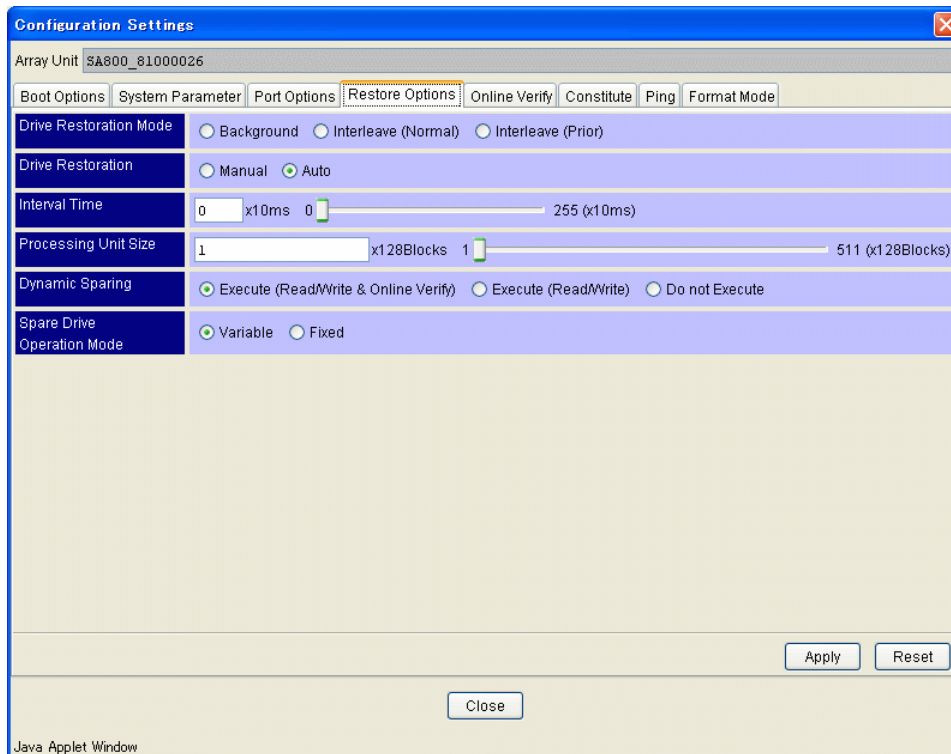

2. Enter the following settings:

Drive Restoration Mode:

- **Background:** Executes drive restoration while host I/O processing is not executed.
- **Interleave (Normal):** Restores the drive at preset time intervals (specified as "Interval Time") giving preference to a host command (restores after executing the command).
- **Interleave (Prior):** Restores the drive at preset time intervals (specified as "Interval Time") taking preference over a host command.

Drive Restoration:

- **Manual:** Starts restoring data and copying by manual operations.
- **Auto:** Automatically starts data and copying restoration.

Interval Time:

The default is 0 to 10 ms with restoration executed at intervals of 0 ms. To set, specify a multiplication factor from 0 to 255 in a unit of 10 ms.

Processing Unit Size:

Specify the size of the data block to be restored. The value of the range of 1 to 511 is specified by a multiple of 128. The minimum value is 128, which restores 65 kB data in a single operation. When Interleave mode is specified, the function restores the data of the processing unit size that is specified, waits for the time interval that is specified, and then starts the next data restoration.

Dynamic Sparing: Specify a mode for data restoration for the spare drive when the error occurrence count controlled by preventive maintenance exceeds the threshold value.

- **Execute (Read/Write & Online Verify):** When the error occurrence count in **Read/Write Error** or **Online Verify Error**, data restoration is performed for the spare drive (when the spare drive is not used), and the error disk is blocked.
- **Execute (Read/Write):** When the error occurrence count in **Read/Write Error** exceeds the threshold value, data restoration is performed for the spare disk in the spare drive (when the spare disk is not used), and the error disk is blocked.
When the error occurrence count in **Online Verify Error** exceeds the threshold value, but Dynamic Sparing is not performed.
- **Do not Execute:** When the error occurrence count in **Read/Write Error** or **Online Verify Error** exceeds the threshold value, but Dynamic Sparing is not performed.

Spare Drive Operation Mode: Specify the spare drive operation mode.

- **Variable:** When a failed drive is replaced, the new drive becomes a spare drive. However, even if the **Spare Drive Operation Mode** is set to **Variable**, it becomes operation of **Fixed** in SMS100.
- **Fixed:** Uses only a drive that is designated as a spare.

3. Click **Apply**.
4. A confirmation message displays. Click **OK**.

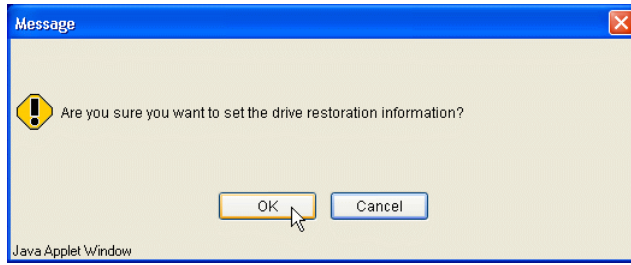

Online Verify

To enable Online Verify Test or to Skip Online Verify:

1. Click **Online Verify** tab.

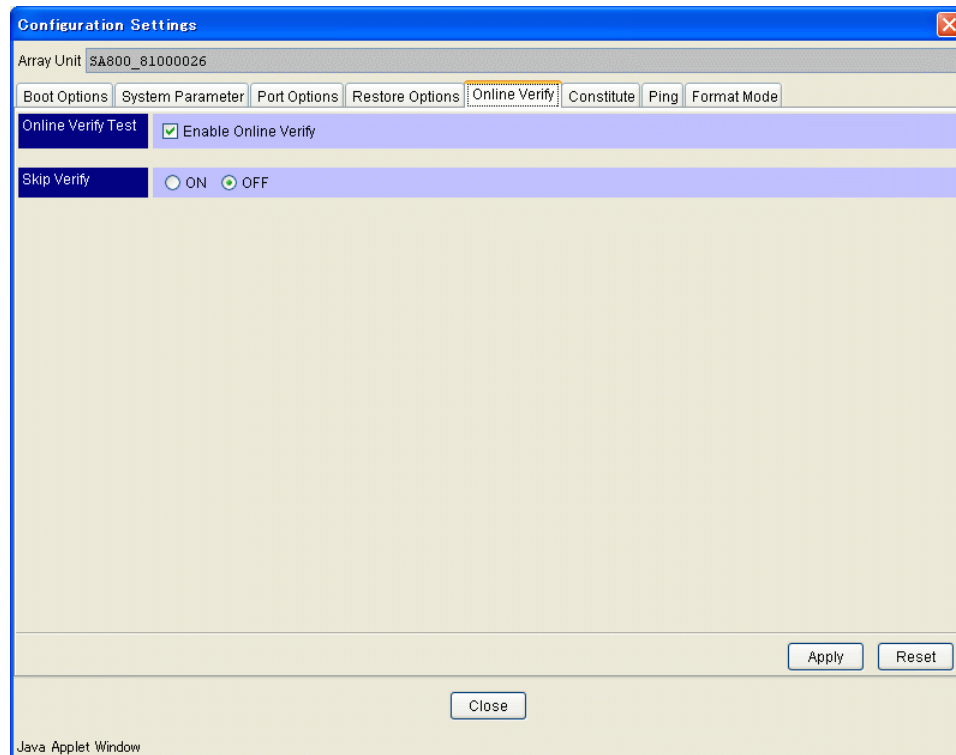

2. Select the desired options:
 - Online Verify Test: Specify whether or not to execute Online Verify Test.
 - **Skip Online Verify**: When a verify command is received from a host, ensure that verification operation is performed.
 - **Cache Verify**. Specify whether or not to execute Cache Verify.
3. Click **Apply**.
4. A confirmation message displays. Click **OK**.

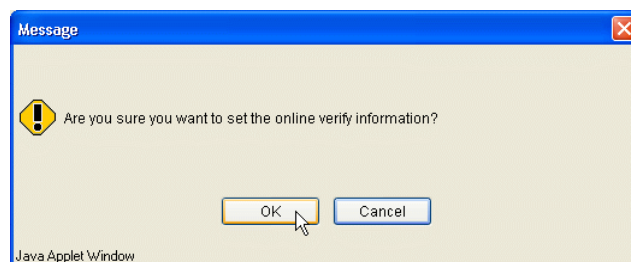

Constitute

This section describes how to output the configuration information of the subsystem in a text file or set the configuration using a text file.

The configuration information output in a text file includes the status of the system parameters, RAID group/logical unit, port information, and the constituent parts of the subsystem. The configuration to be set includes the system parameters, RAID group/logical unit, and port information. The status of the constituent parts of the subsystem cannot be set.

The configuration information is handled with separate text files for the system parameters, for RAID group/logical unit, and for port information.

Copying configuration information between subsystems can be executed by outputting a text file of the configuration from the subsystem, then using the output text file to set another subsystem.

Editing a text file to set the subsystem can be done, however, it is recommended that this function be used for the configuration of the same subsystem. To change the configuration, use individual functions.

File Output for System Parameters

To output the settings of the system parameters for the subsystem in text form to a specified file:

1. Click the **Constitute** tab.

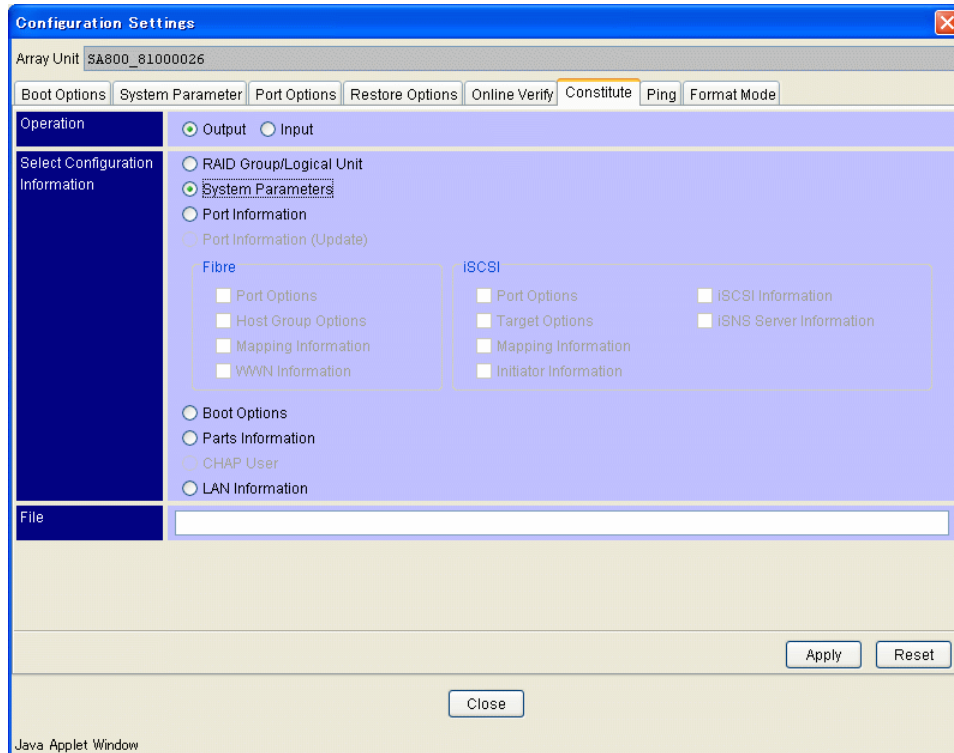

2. Check the **System Parameters** option in the **Select Configuration Information** box.
3. Specify the file name to which the configuration file will be output.
4. Select the **Output** option.
5. Click **Apply**.
6. When the confirmation message displays, click **OK**.

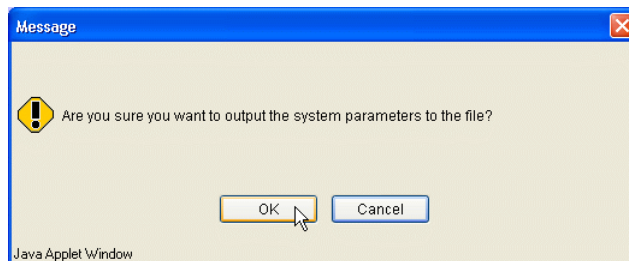

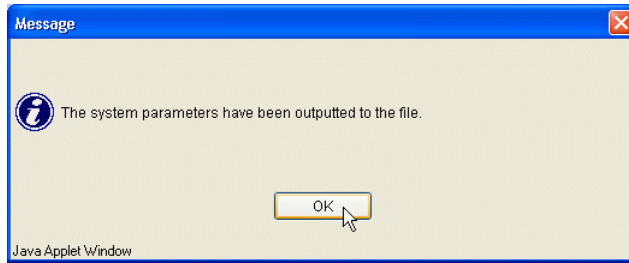

System parameter information is saved in the form of a text file with the specified file name. The format of the output file consists of the following items. The outline of the layout of the output file is shown in Figure 4.2.

- File header
- File format revision
- Subsystem registration name with Navigator 2
- Output time (Server time where Navigator 2 is installed)
- Firmware revision
- Subsystem type
- Serial number
- Navigator 2 version
- Common controller parameters
- Controller parameters

Figure 4.2 System Parameter Output File Format

```

System parameter list.
File Format : 2.00

DF Name : SA800 81000026
Date : 2008/11/20 06:03:59
Firmware Revision : 1860/A-A
Array Unit Type : SA800
Serial Number : 81000026
#HSNM2 Version : 6.00

---- System Parameter ----
Options
  Turbo LU Warning = OFF
  Write Unique Response Mode = OFF
  Auto Reconstruction Mode = OFF
  Forced Write Through Mode = OFF
  ShadowImage I/O Switch Mode = OFF
  Synchronize Cache Execution Mode = OFF
  Drive Detach Mode = OFF
Operation if the Processor failures Occurs = Reset the Fault
Web Title = ""
---- CTL0 Parameter ----
Write & Verify Execution Mode = OFF
---- CTL1 Parameter ----
Write & Verify Execution Mode = OFF

```

Setting System Parameters with a File

Set the system parameters in the subsystem with the information described in the file. If you set the system parameters using a file that was output when a priced optional feature is in an unlocked state, the setting may terminate abnormally. To set system parameters, use a file that was output when all priced optional features are in a locked state.

For a dual system, setting cannot be executed if one of the controllers is detached. Verify that the subsystem is operating normally.

When system parameters are set, the subsystem cannot execute commands from the host. The functions of Navigator 2 can no longer work; however, the wizard sets the system parameters and failure monitoring.

To set subsystem parameters with a file:

1. Edit the file for setting the system parameters to set the subsystem. The file has a specified format. The format of the file is the same as that of the file output by the subsystem. Refer to the following sections of this manual for the format and parameters of the file respectively.

For the format of the file, see section 0.

2. Click the **Constitute** tab.
3. Click the **System Parameter** option.
4. Specify the file name of the file that describes the system parameters edited in step 1. The specified file name displays in the text box.
5. Select the **Input** option.
6. Click **Apply**.
7. When the confirmation message displays, click **OK**.

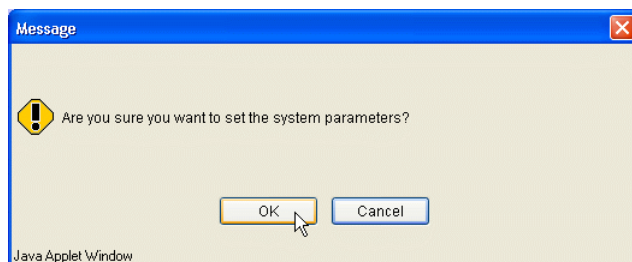

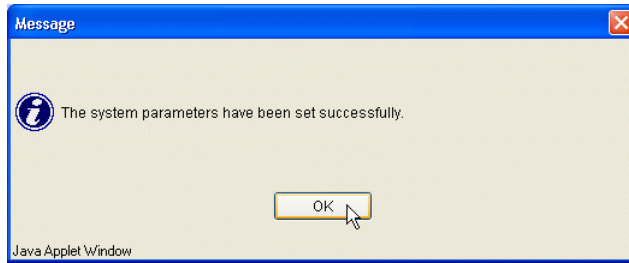

RAID Groups/Logical Units and Configuration File Output Status

To output RAID group/logical unit definition information already set in the subsystem to a specified file in a text format:

1. Click the **Constitute** tab.

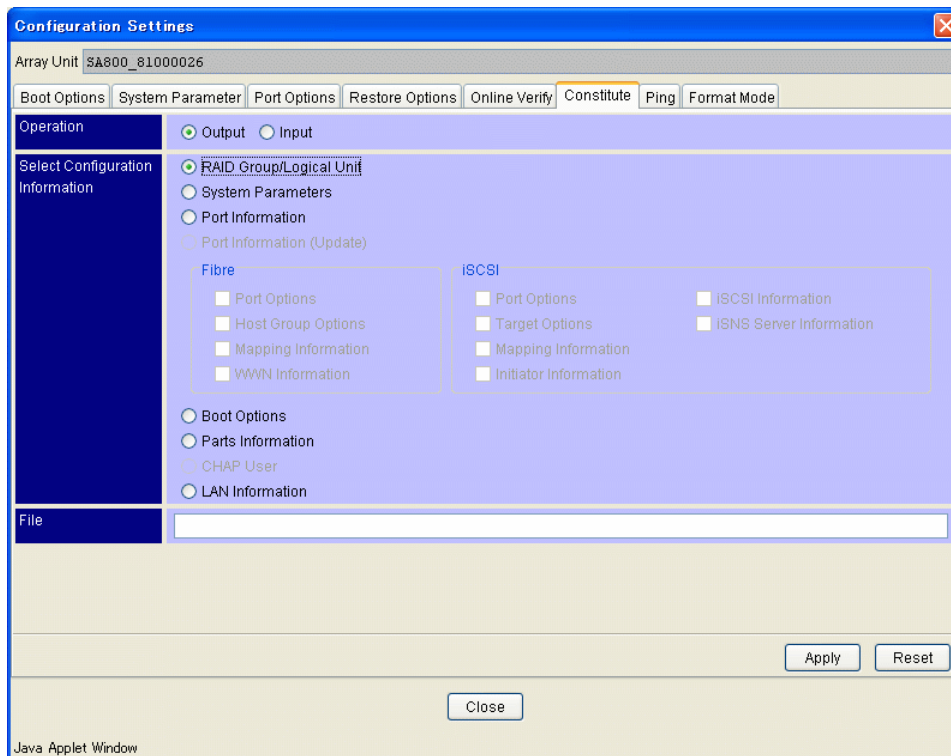

2. Click the **RAID Group/Logical Unit** option in the **Select Configuration Information** box.
3. Specify the file name to output the file of the configuration.
4. Select the **Output** option.
5. Click **Apply**.
6. When the confirmation message displays, click **OK**.

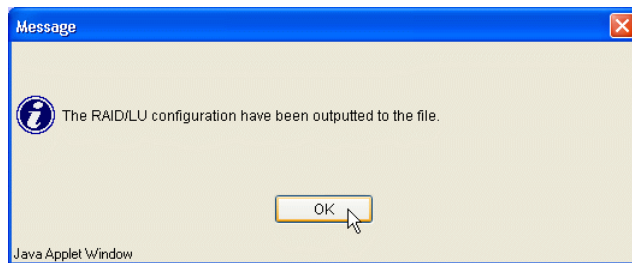
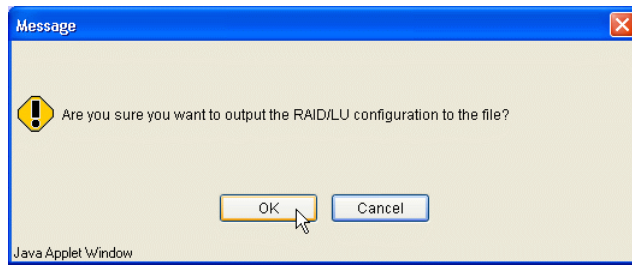

System parameter information is saved in the form of a text file with the specified file name.

The format of the output file consists of the following items. An outline of the layout of the output file is shown in Figure 4.3.

- File header
- File format revision
- Subsystem registration name at Navigator 2
- Output time (Server time where Navigator 2 is installed)
- Firmware revision
- Subsystem type
- Serial number
- Navigator 2 version
- RAID group/logical unit configuration
- Drive configuration

```

Array unit configuration information list.
File Format : 2.00

DF Name : SA800_81000026
Date : 2008/11/20 06:03:35
Firmware Revision : 1860/A-A
Array Unit Type : SA800
Serial Number : 81000026
#HSNM2 Version : 6.00

---- RAID Configuration Information ----
---- RAID Configuration ----
RAID RAID Start Location Number of HDU Number of Free Capacity Type
Group Level [Unit No. HDU No.] in parity group parity group [block]
0 6 0 0 6 1 3806461952 SATA

-- End

---- Drive Location of RAID Group ----
RAID Group Drive Location(Unit No.-HDU No.)
0 0-0 0-1 0-2 0-3 0-4 0-5

-- End
-- End

---- LU Configuration Information ----
---- LU Configuration ----
LU Capacity Status RAID RAID Number of Stripe Size Capacity Type
No. [block] Group Level Cache Partition [KB] [MB/GB/TB]
0 2097152 Normal 0 6 1 256 1.0 GB SATA
1 4194304 Normal 0 6 0 256 2.0 GB SATA
:

-- End
-- End

---- Drive Configuration Information ----
Location Status Type Vendor ID Product ID Revision Serial Number
Capacity Drive Type Rotational Speed
Unit0 ,HDU0 Normal Data HITACHI HDS725050KLA360 6666 HSAT500A
500GB SATA 7200rpm
Unit0 ,HDU1 Normal Data HITACHI HDS725050KLA360 6666 HSAT500B
500GB SATA 7200rpm
:

-- End

```

Figure 4.3 RAID Group/Logical Unit Configuration Information Output File Format

Setting RAID Group/Logical Unit Definition with a File

Set the subsystem according to the RAID group/logical unit setting information described in a file. If the setup of the RAID group/logical unit is configured and completed, all of the previous user's data will be lost. The RAID group/logical unit configuration, as specified in the file, is set after deleting the current RAID group/logical unit. If user data is needed, configure the setting after backing up the system.

1. Edit the file to set the RAID group/logical unit information in the subsystem. The file has a specified format. The format of the file is the same as that of the file output by the subsystem. For the proper file format, see section 0.

The parameters in the file are **RAID configuration information**, **LU configuration information**, and **Drive information** in the format of the output file. In the output file, there are items that give the status of constituent parts. Ignore these items while setting up the configuration. The parameters are described below:

- **RAID configuration information:** Sets the RAID configuration which specifies RAID group number, RAID level, and RAID size. If the RAID group is not set, "-" is shown after **Level**, and no other parameters are set.

- **LU configuration information:** Sets the logical unit configuration.

Specify the logical unit number, logical unit capacity, logical unit status, RAID group number, RAID level, cache partition number, stripe size, and drive type.

In logical unit status, for cases where formatting is to be executed, specify **Normal**. Formatting cannot be executed if another status is specified.

In cases where the full capacity of the RAID group is allocated to one logical unit, specify **All** in **Capacity**.

In cases where logical units of less than the maximum logical unit number are created, specify at the end that "After nn, not define" (nn: the last logical unit number + 1).

- **Drive information:** Sets the configuration of the HDU installed in the subsystem. For an HDU that is not installed, do not specify anything.

When a capacity bigger than that of the installed HDU is specified, it is regarded as an error and not set.

2. Click the **Constitute** tab.
3. Click the **RAID Group/Logical Unit** option.
4. Specify the name of the file that describes the RAID group definition and logical unit definition edited in step 1. The specified file name is shown in the text box.
5. Select the **Input** option.
6. Click **Apply**.
7. Messages display and warn you of the following:
 - The procedure deletes the current RAID/LU configuration.
 - User data in the logical units are invalidated and cannot be recovered.To continue, click **OK** in the messages.

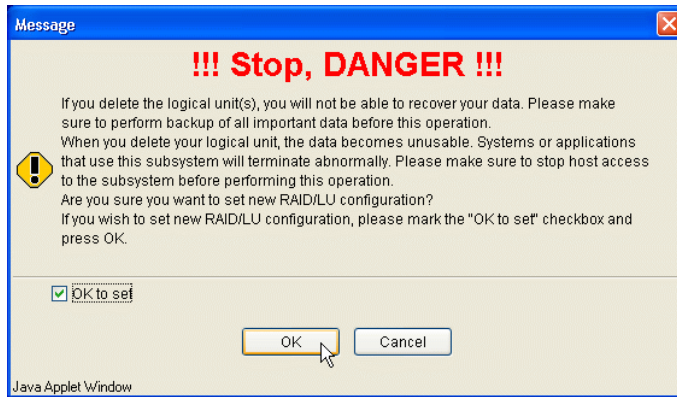
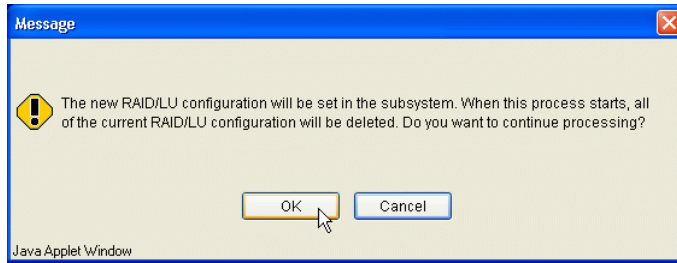

A message displays, stating that the RAID configuration setting has started:

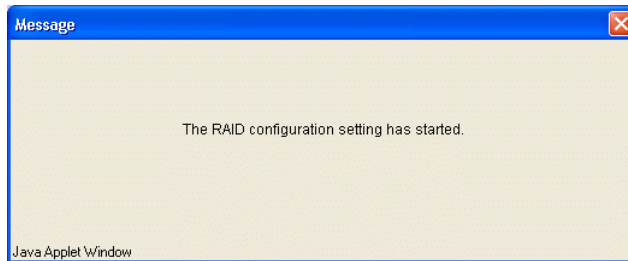

When the setting of the RAID group ends abnormally, an error message displays and interrupts processing.

If the setting of the RAID group ends normally, a message that the setting of logical unit has started displays, and executes the logical unit setting.



8. A message displays stating that the setting is complete. Click **OK**.



Port Information File Output

To output the settings of the port information for the subsystem in text form to a specified file:

1. Click the **Constitute** tab.

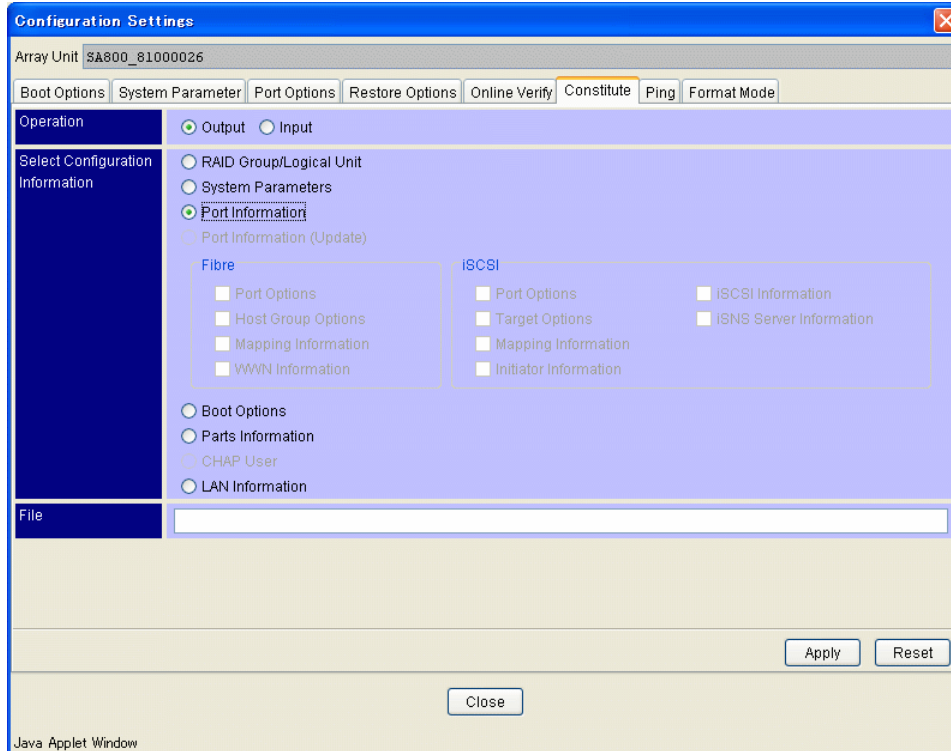

2. Check the **Port Information** option in the **Select Configuration Information** box.
3. Specify the file name to which the port information file will be output.
4. Click the **Output** option.
5. Click **Apply**.
6. When the confirmation message displays, click **OK**.

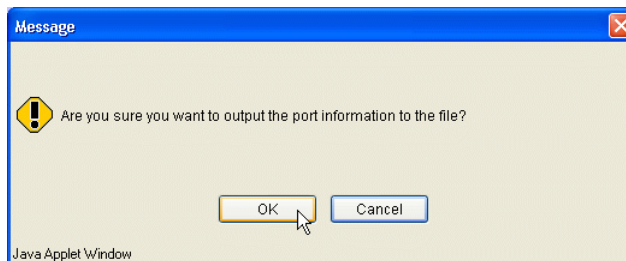

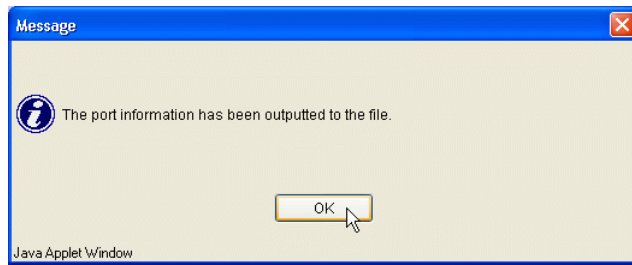

The port information is saved in the form of a text file with the specified file name.

The format of the output file consists of the following items. The outline of the layout of the output file is shown in Figure 4.4.

- File header
- File format revision
- Subsystem registration name at Navigator 2
- Output time (Server time where Navigator 2 is installed)
- Firmware revision
- Subsystem type
- Serial number
- Navigator 2 version
- Mapping mode
- Port type
- Port information
- iSNS information
- Port options
- Target list
- Host system configuration
- Target options
- LU mapping information
- LUN Manager information
- Initiator information

Figure 4.4 Format Outline of Port Information Output File

```

Configuration Information list.
File Format : 2.02

DF Name : SA800_81000026
Date : 2010/03/0 06:04:25
Firmware Revision : 1890/A-A
Array Unit Type : SA800
Serial Number : 81000026
#HSNM2 Version : 9.00

---- CommonInformation ----
MappingMode = ON

---- CTL0 ----
---- PortA ----
PortType = iSCSI
---- iSCSIPortInformation ----
PortNumber = 3260
KeepAliveTimer = 60
MTU = 1500
Ether Address = 00:00:87:66:FC:E4
IPv4
IPv4 Address = 192.168.0.200
IPv4 SubnetMask = 255.255.255.0
IPv4 DefaultGateway = 0.0.0.0

---- iSNS Information ----
ServerUse = Not Used
IPAddress = 0.0.0.0
PortNumber = 3205

---- PortOptions ----
Reset/LIP Mode(Signal) = OFF
Reset/LIP Mode(Process) = OFF
LIP Port All Reset Mode = OFF

---- TargetList ----
---- TargetInformation ----
TargetNumber = 0
TargetAlias = "T000"
iSCSI Name = "iqn.1994-04.jp.co.hitachi:rsd.d8a.t.00026.0a000"
Authmethod = CHAP,None

---- HostSystemConfiguration ----
Platform = not specified
Middleware = not specified

---- TargetOptions ----
Host Connection Mode 1 = Standard Mode
Host Connection Mode 2
HP-UX Mode = OFF
PSUE Read Reject Mode = OFF
Mode Parameters Changed Notification Mode = OFF
NACA Mode = OFF
Task Management Isolation Mode = OFF
Unique Reserve Mode 1 = OFF
Port-ID Conversion Mode = OFF
Tru Cluster Mode = OFF
Product Serial Response Mode = OFF
Same Node Name Mode = OFF
CCHS Mode = OFF
Inquiry Serial Number Conversion Mode = OFF
NOP-In Suppress Mode = OFF
S-VOL Disable Advanced Mode = OFF

```

```

---- LuMapping ----
      H-LUN      LUN
          0          0
          1          1
          :
-- TargetInformationEnd
-- TargetListEnd

--- LUNManagementInformation ---
Security = OFF
---- InitiatorList ----
-- InitiatorListEnd

---- PortB ----
:
:

```

Setting Port Information with a File

To set port information settings with a file:

1. Click the **Constitute** tab.

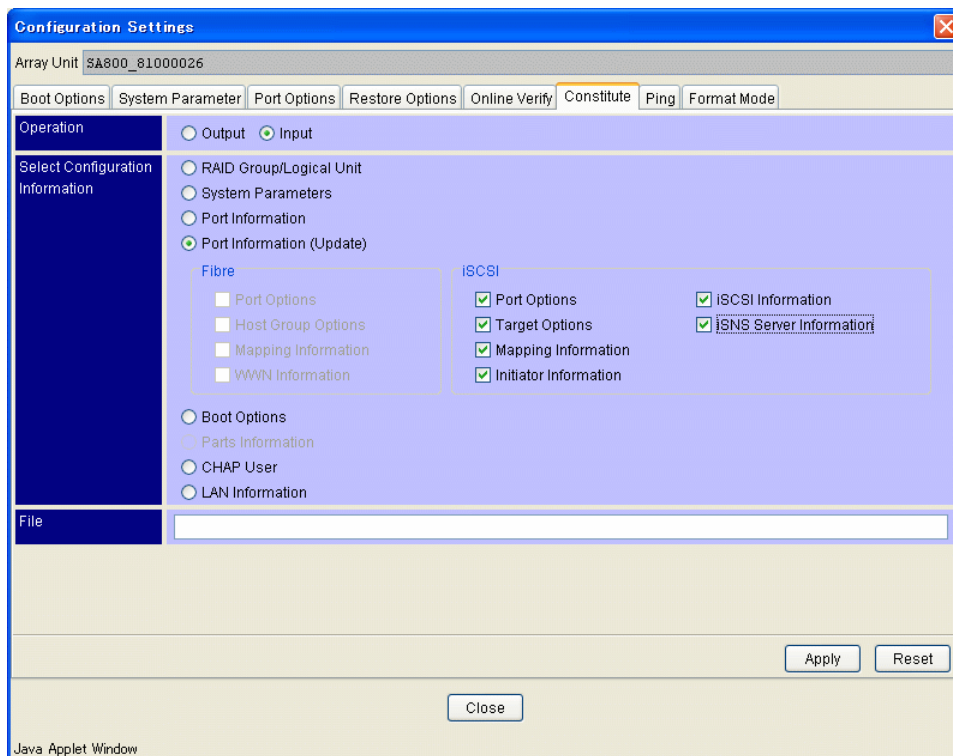

2. Click the **Port Information (Update)** option in the **Select Configuration Information** box.
3. Select the items that you will set from setting information for **iSCSI**. An error will occur if nothing is chosen. (When the LUN Manager function is valid, the initiator Information displays for setting information for **iSCSI**.)
4. Specify the file name to which the port information file will be input.

5. Select the **Input** option.
6. When the confirmation message displays, click **OK** to continue.

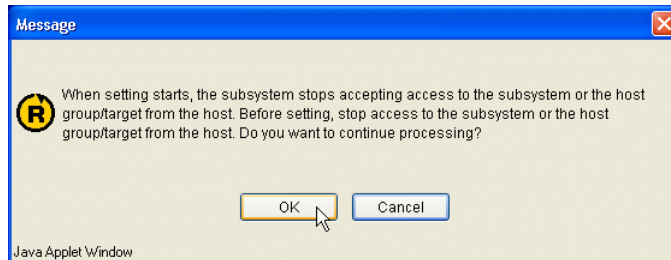
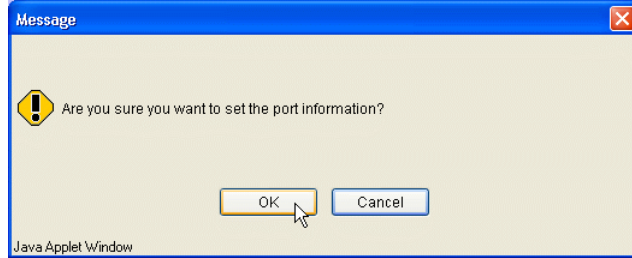

File Output of Boot Option Information

1. Click the **Constitute** tab.

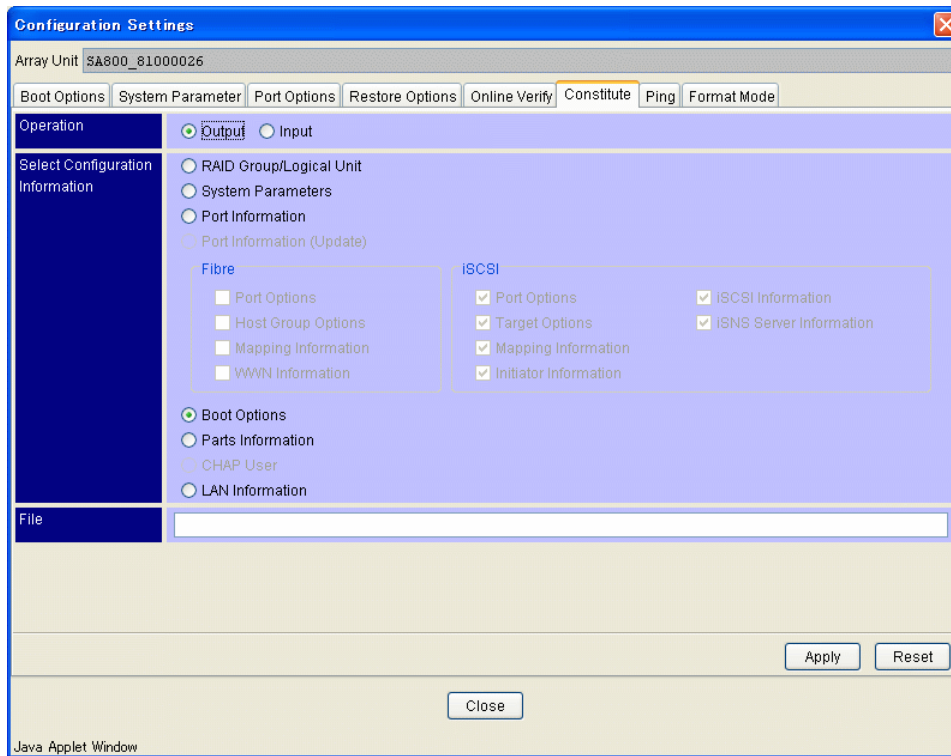

2. Check **Boot Options** in the **Select Configuration Information** box.
3. Specify the file name to which the boot option information file will be output.
4. Click **Apply**.
5. When the confirmation message displays, click **OK**.

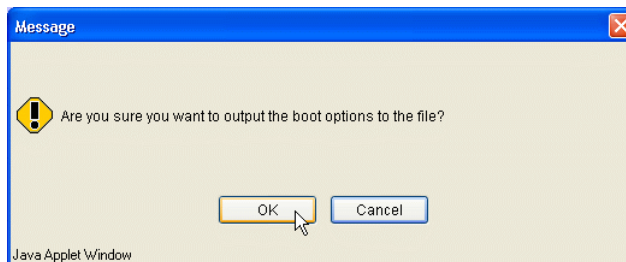

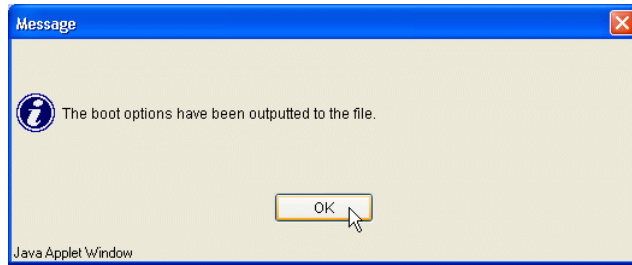

The boot options information is saved in the form of a text file with the specified file name.

The format of the output file consists of the following items. The outline of the layout of the output file is shown in Figure 4.5.

- File header
- File format revision
- Subsystem registration name at Navigator 2
- Output time (Server time where Navigator 2 is installed)
- Firmware revision
- Subsystem type
- Serial number
- Navigator 2 version
- Boot options information

Figure 4.5 Format Outline of Boot Options Information Output File

```
Boot Option list.
File Format : 2.00

DF Name : SA800_81000026
Date : 2008/11/20 06:04:42
Firmware Revision : 1860/A-A
Array Unit Type : SA800
Serial Number : 81000026
#HSNM2 Version : 6.00

---- Boot Options ----
System Startup Attribute = Dual Active Mode
Delay Planned Shutdown[min.] = 0
INQUIRY Information
  Vendor ID = HITACHI
  Product ID = DF600F
  ROM Microprogram Version =
  RAM Microprogram Version =
```

Setting Boot Option Information with a File

When the boot option is set, the subsystem requires a restart after setting changes.

Warning: Rebooting requires stopping I/O from the host.

1. Click the **Constitute** tab.

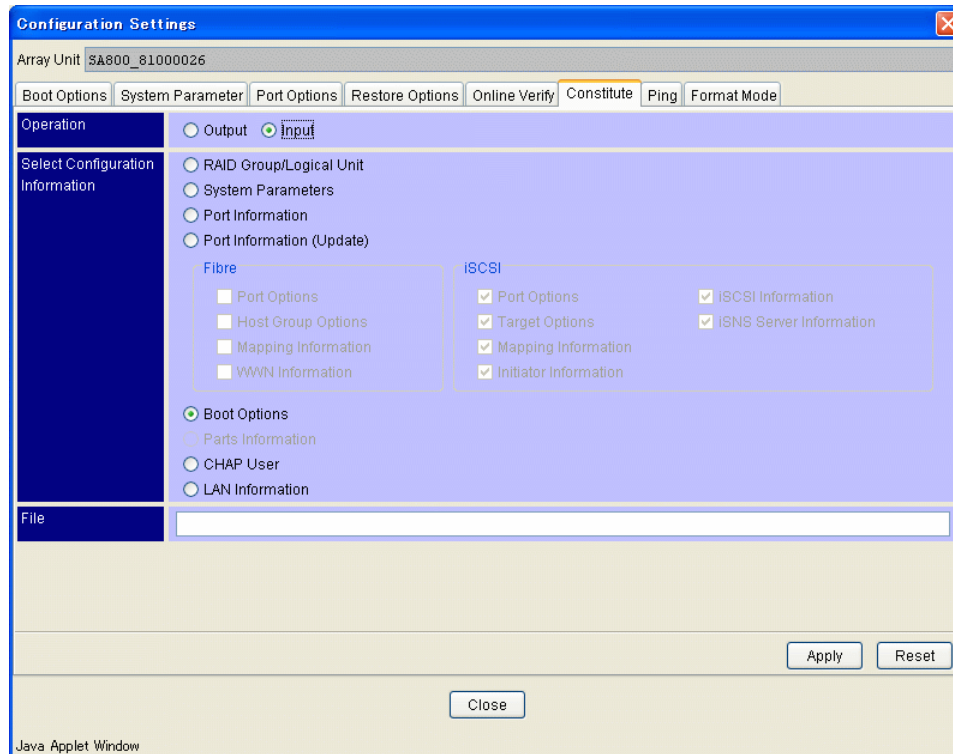

2. Check **Boot Options** and **Input** option in the **Select Configuration Information** box.
3. Specify the file name to which the boot option information file will be input.
4. Click **Apply**.

- When the confirmation message displays, click **OK**.

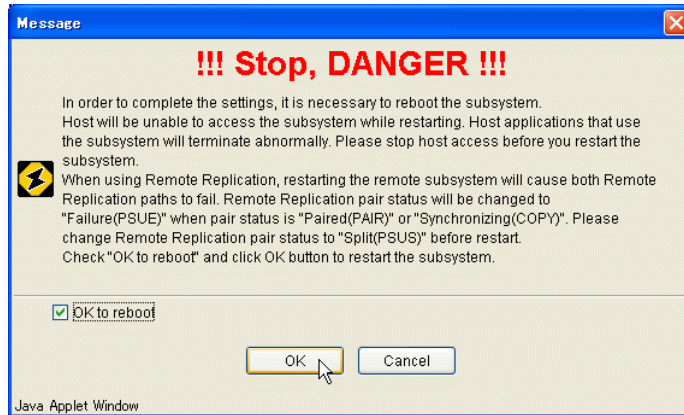
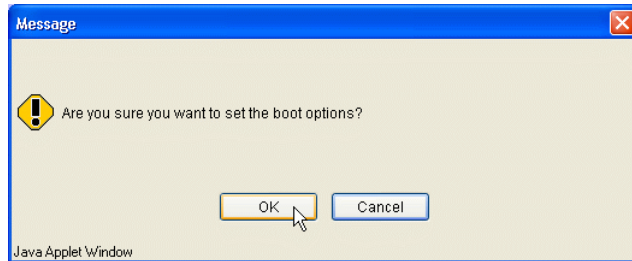

When you choose to restart the subsystem, the time the restart began is displayed. This usually takes approximately four to fifteen minutes.

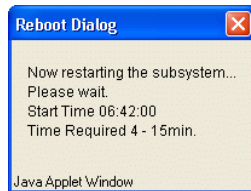

Note: It may take time for the subsystem to respond, depending on the condition of the subsystem. If it does not respond after 15 minutes or more, check the condition of the subsystem.

- A message appears, stating that the restart is successful. Click **OK**.

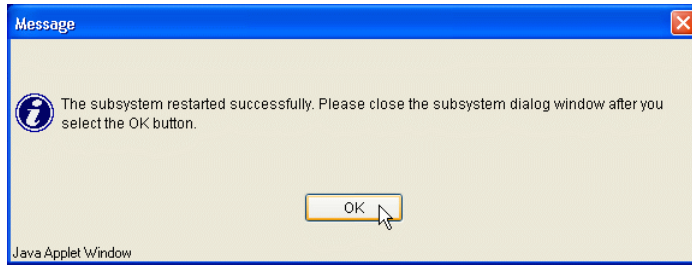

7. A message appears, click **Close**.

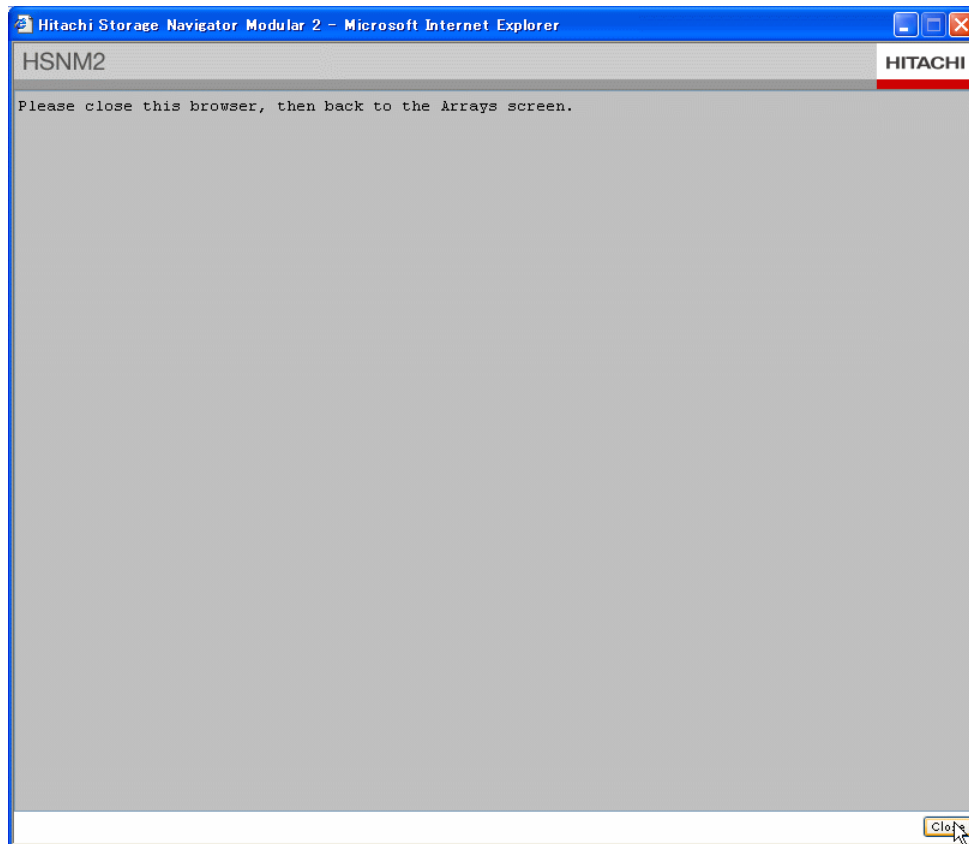

File Output of Parts Information

To output parts information to a file:

1. Click **Open Advanced Settings**.
After a few minutes, an **Array Unit** screen displays.
2. Select **Configuration Settings** icon in an **Array Unit** tree view.
3. Click **Set**.
The **Configuration Settings** tab page is displays.
4. Click the **Constitute** tab.

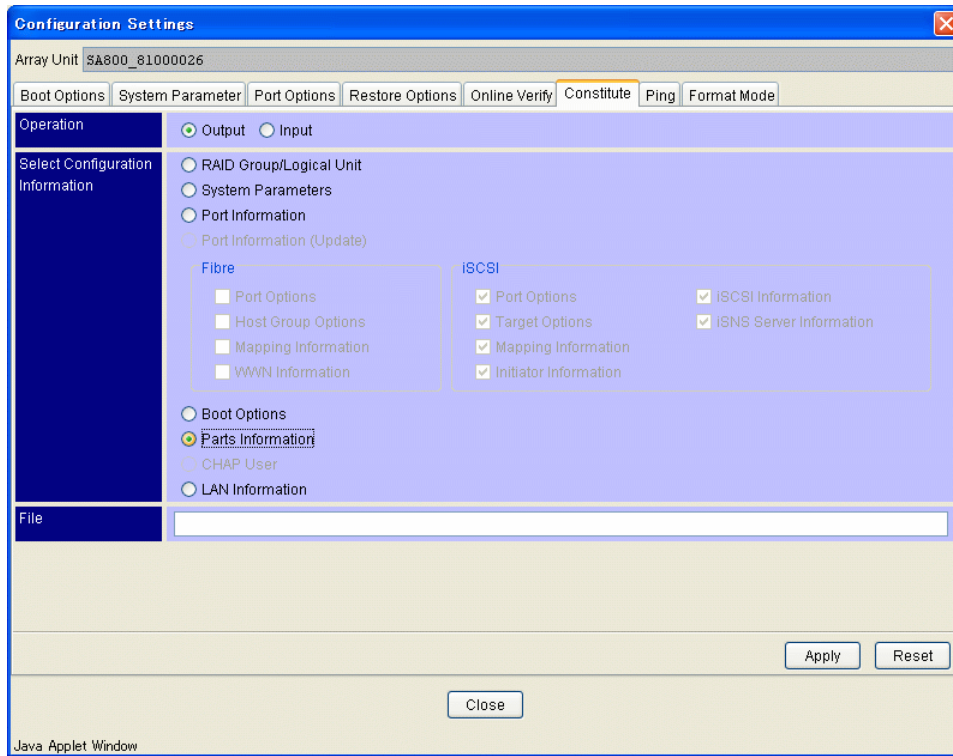

5. Check **Parts Information** in the **Select Configuration Information** box.
6. Specify the file name to which the parts information file will be output.
7. Click **Apply**.
8. When the confirmation message displays, click **OK**.

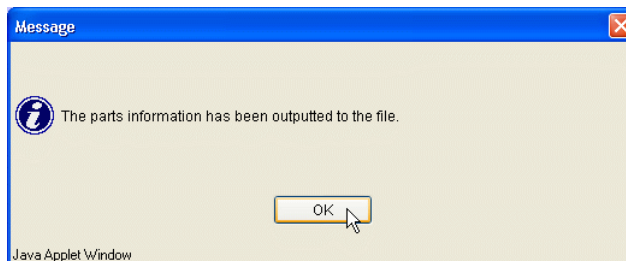
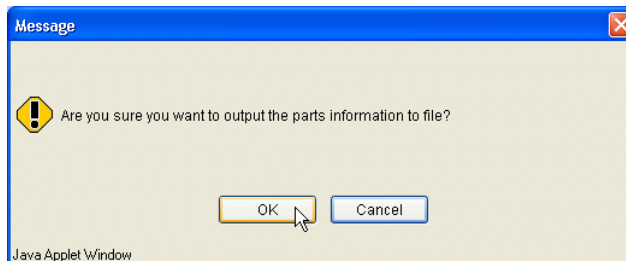

Setting CHAP User Information with a File

1. Click the **Constitute** tab.

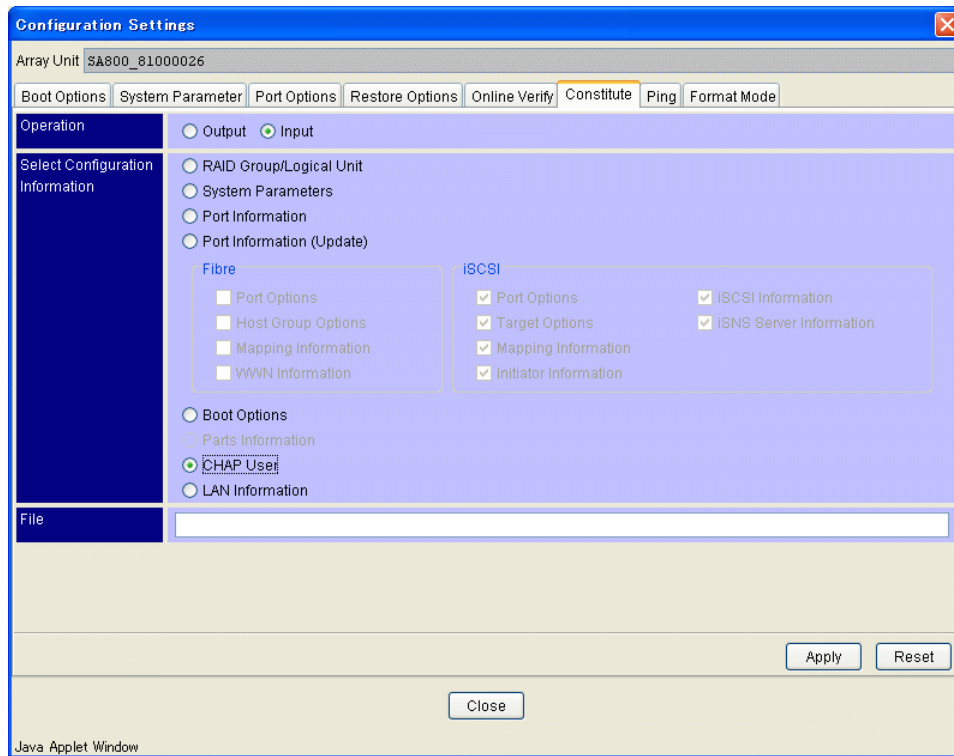

2. Click the **CHAP User** option in the **Select Configuration Information** box.
3. Specify the file name to which the CHAP User information file will be input.
4. Select the **Input** option.
5. A confirmation message displays. To continue, click **OK**.

The CHAP User information setting file format is shown in Table 4.2.

Table 4.2 CHAP User Information Setting File Format

File Contents	Descriptions
User name,secret,Target No. or alias ...	The lines are invalid until <CHAP User> appears.
<CHAP User>,,	The valid lines are from <CHAP User> to <END>.
<Port 0A>,,	The line specifies the port. (<Port ALL> specifies all ports)
hitachi-0,abcdefghij00,alias0	The first column is CHAP User, and the second column is Secret.
hitachi-1,abcdefghij01,alias1	The third row and the following are aliases of Target to assign.
#hitachi-1,abcdefghij01,alias1	The line with the first character of # is a comment line. (Invalid line)
hitachi-2,abcdefghij02,3	The Target number can be specified as the alias of Target.
<Port 0B>,,	
<Add CHAP User>,,	If <Add CHAP User> is specified, CHAP User is added.
hitachi-0,abcdefghij00,alias0	If nothing is specified, all CHAP Users are deleted, and then added.
hitachi-1,abcdefghij01,alias0,alias01,alias02	One or more Targets can be specified.
<Port 1A>,,	
<Port 1B>,,	
<END>,,	The line of <END> and the following are all invalid lines.

File Output of LAN Information

To output the settings of the LAN information for the subsystem in text form to a specified file:

1. Click the **Constitute** tab.

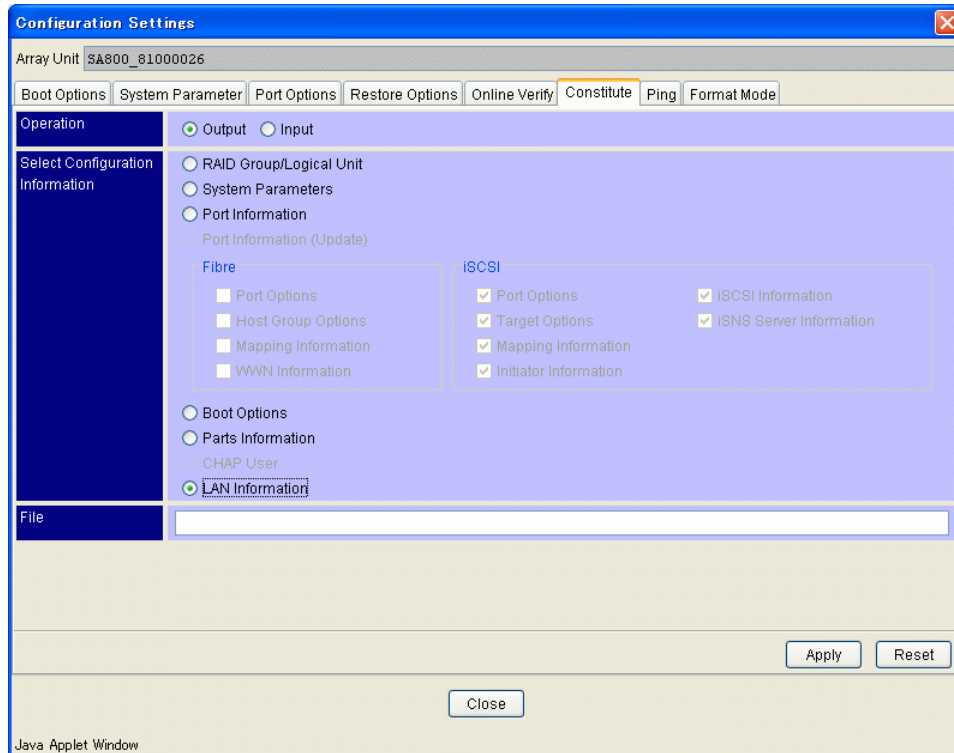

2. Check the **LAN Information** option in the **Select Configuration Information** box.
3. Specify the file name to which the LAN information file will be output.
4. Click the **Output** option.
5. Click **Apply**.
6. When a message displays, confirming that the LAN information is output with the specified file name, click **OK**.

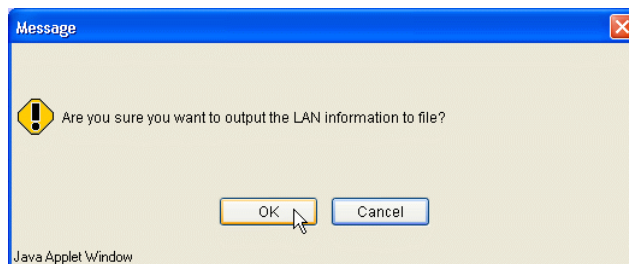



The LAN information is saved in the form of a text file with the specified file name.

The format of the output file consists of the following items. The outline of the layout of the output file is shown in Figure 4.6.

- File header
- File format revision
- Subsystem registration name at Navigator 2
- Output time (Server time where Navigator 2 is installed)
- Firmware revision
- Subsystem type
- Serial number
- Navigator 2 version
- User LAN information
 - Maintenance Port IP Address Automatic Change Mode
- Maintenance Port LAN information

Concerning the Ether Address of the user LAN information, only the information on the controller connected over the LAN is output. To output the information on the both controllers, connect the both controllers over the LAN. When the information is output in the state in which the controller(s) is (are) blocked, the LAN information on the blocked controller(s) is output as 0.0.0.0.

Figure 4.6 Format Outline of LAN Information Output File

```
LAN parameter list.
File Format : 2.00

DF Name : SA800 81000026
Date : 2008/11/20 06:05:15
Firmware Revision : 1860/A-A
Array Unit Type : SA800
Serial Number : 81000026
#HSNM2 Version : 6.00

---- User LAN Parameter ----
Maintenance Port IP Address Automatic Change Mode = OFF
---- CTL0 Parameter ----
  IPv4
    DHCP = OFF
    IPv4 Address = 125.30.9.143
    IPv4 Subnet Mask = 255.0.0.0
    IPv4 Default Gateway = 125.11.1.1
    Negotiation = Auto
    Ether Address = 00:00:87:C6:46:E1
---- CTL1 Parameter ----
  :
  :

---- Maintenance LAN Parameter ----
---- CTL0 Parameter ----
  IPv4
    IPv4 Address = 10.0.0.16
---- CTL1 Parameter ----
  IPv4
    IPv4 Address = 10.0.0.17
```

Setting LAN Information with a File

Warning: The User LAN Parameter (Maintenance Port IP Address Automatic Change Mode, IP Address, Subnet Mask, Default Gateway) and Maintenance LAN Parameter (Network Address) can be set up. The other information cannot be set up.

To set LAN settings with a file:

1. Click the **Constitute** tab.

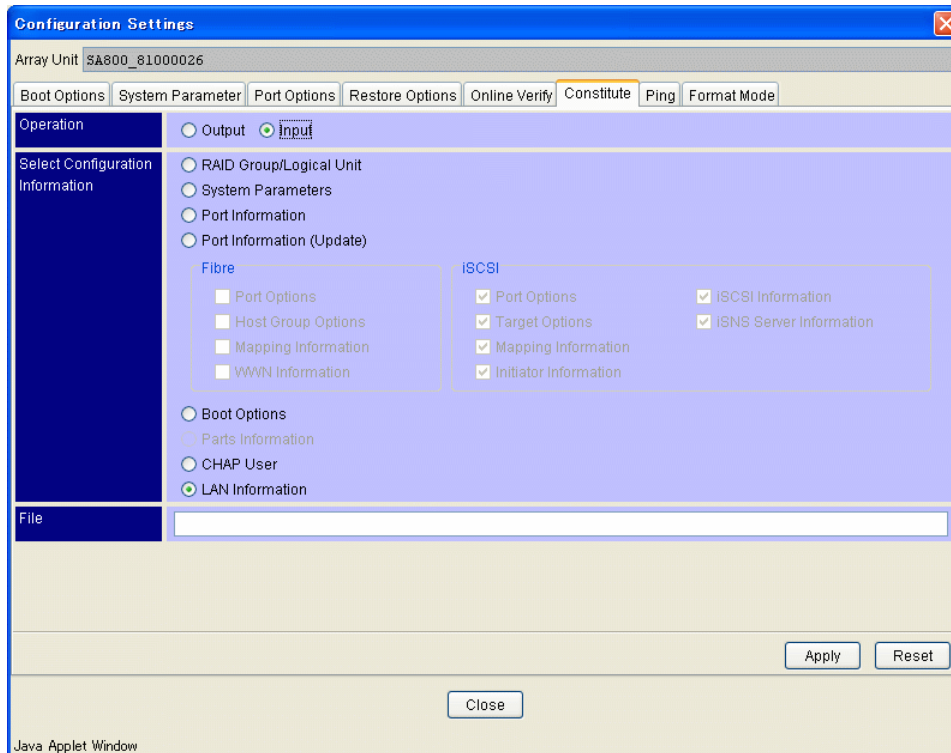

2. Click the **Input** option in the **Operation** box.
3. Check the **LAN Information** option in the **Select Configuration Information** box.
4. Specify the file name to which the LAN information file will be input.
5. Click **Apply**.
6. A confirmation message displays. To continue, click **OK**.

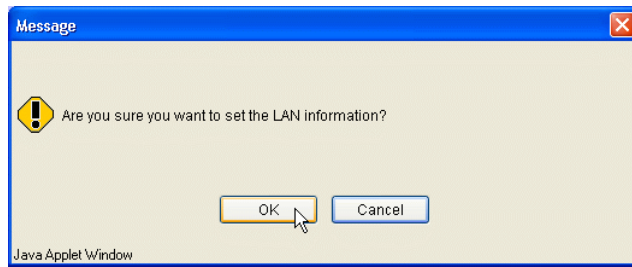

7. Follow the information in messages that appear. Click **Close**.

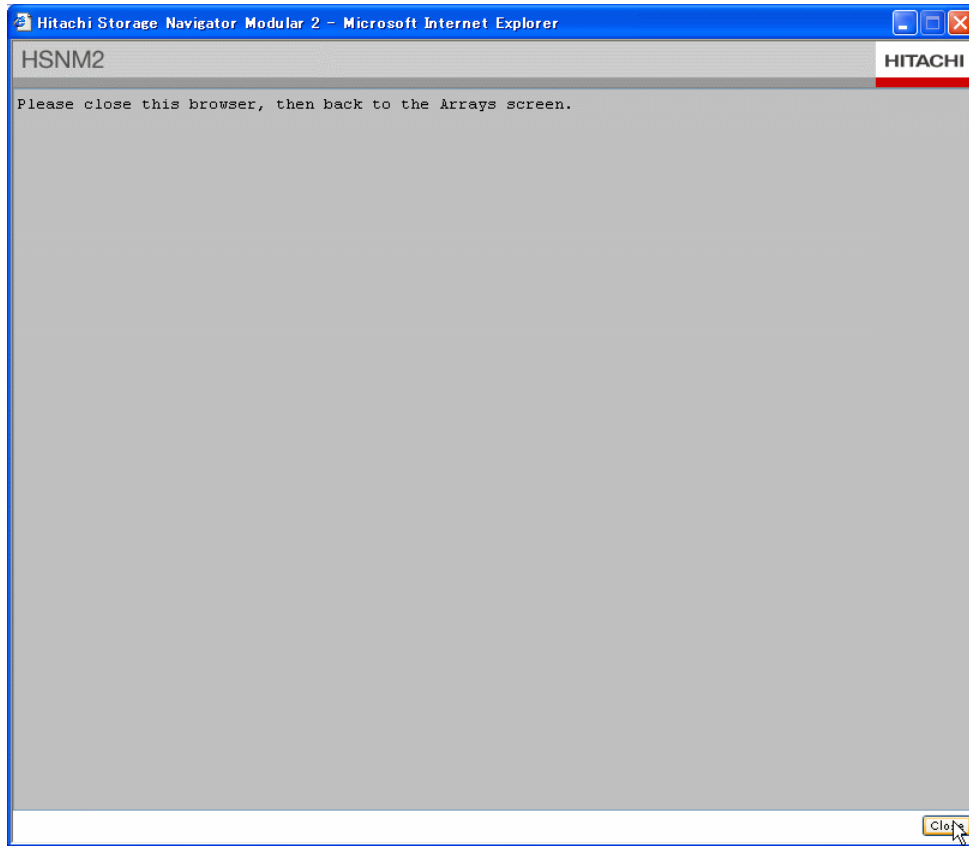

Ping

Sends the ping to the initiator (host) and displays the result of the sending.

1. Click the **Ping** tab.

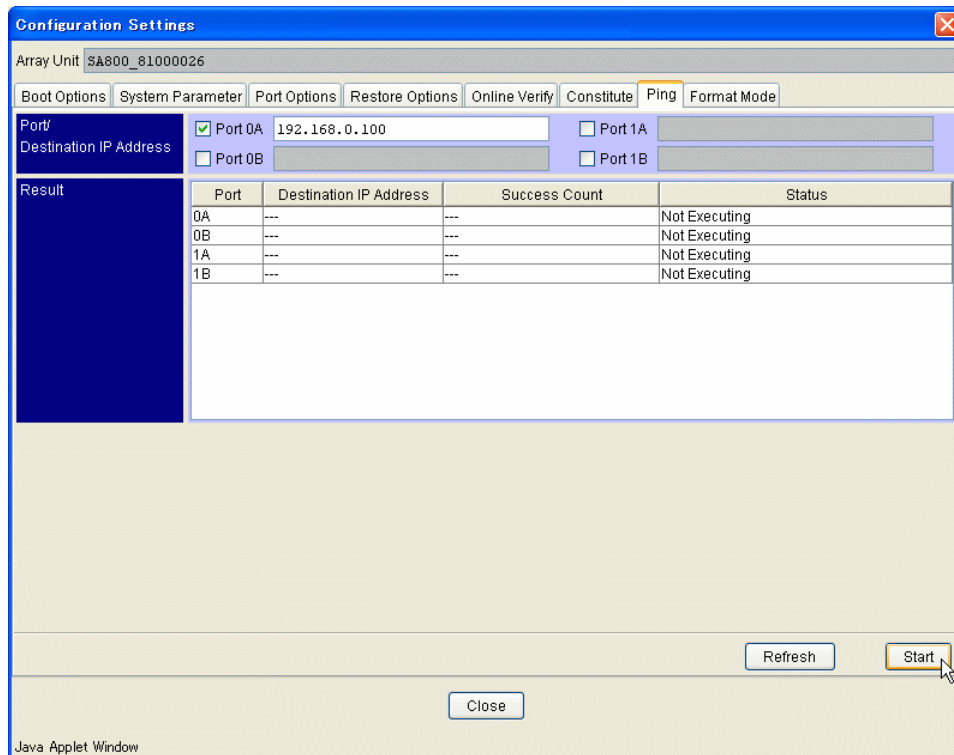

2. Set the ping parameters:
 - **Port/Destination IP Address:** Select the port that sends the ping. And specify the IP address of the initiator.
3. Click **Start**.
4. Click **OK** to continue.

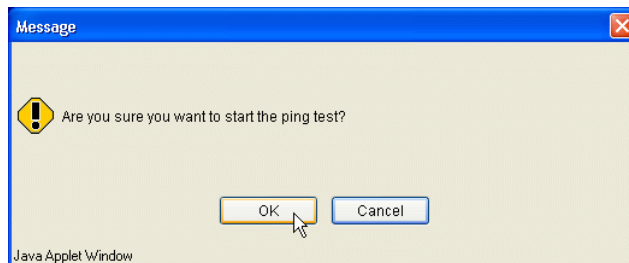

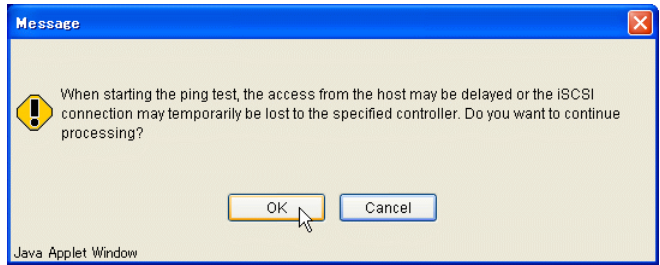

The result displays.

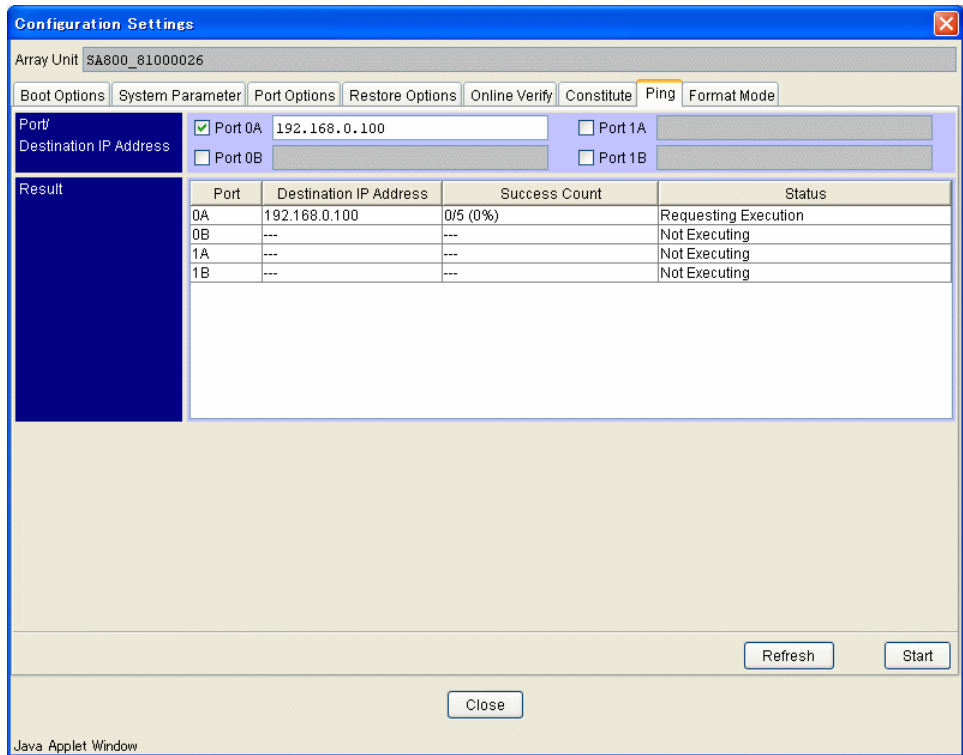

5. Select **Refresh** as necessary to display the latest information.

Format Mode

Changes to Format Priority Mode apply without restarting the subsystem.

1. Click the **Format Mode** tab.

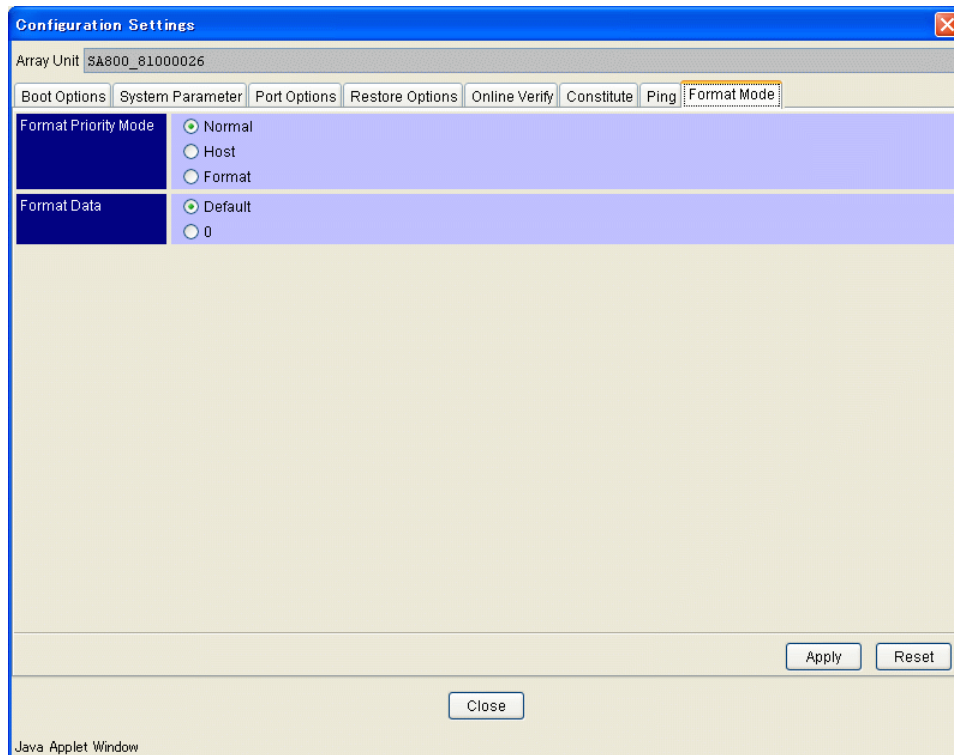

2. Select the **Format Priority Mode** and **Format Data** settings.

Format Priority Mode:

- **Normal:** Formats at an idle time when no host I/O is executed.
- **Host:** Host's I/O is executed preferentially.
- **Format:** Subsystem formats are done preferentially.

Format Data: Specify a format data.

3. Click **Apply**.
4. A confirmation message displays. Click **OK**.

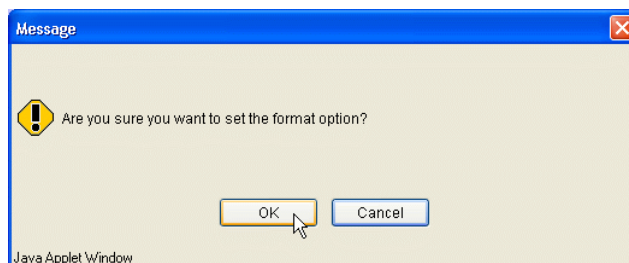

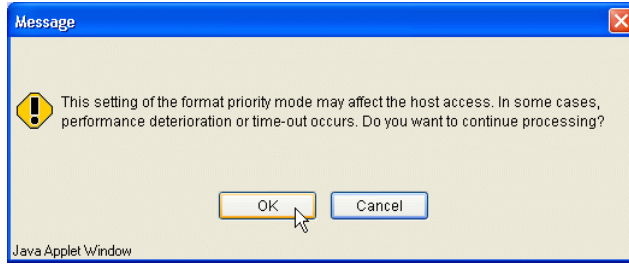

Access Mode

The access mode default setting is **Enable** for each port.

You can set to **Disable** the access mode if necessary.

1. Click the **Access Mode** plus sign. Select **Mapping Mode**.

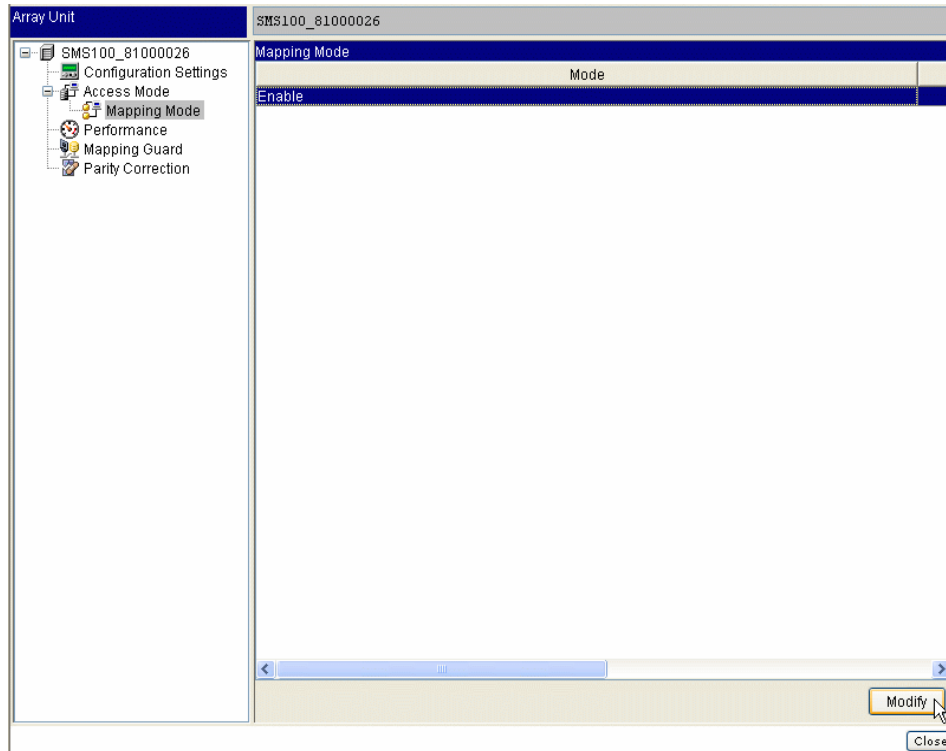

2. On the **Mapping Mode** list, select **Enable or Disable**, and click **Modify**.

The **Mapping Mode** dialog box displays.

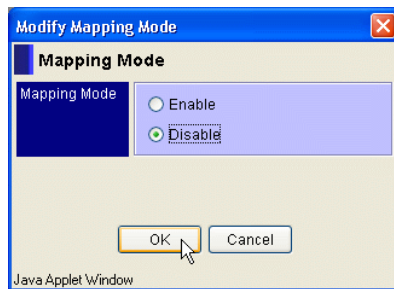

3. Select **Disable or Enable** and click **OK**.
4. A confirmation message displays. Click **OK**.

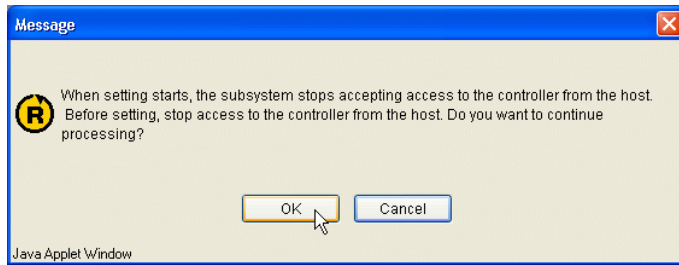
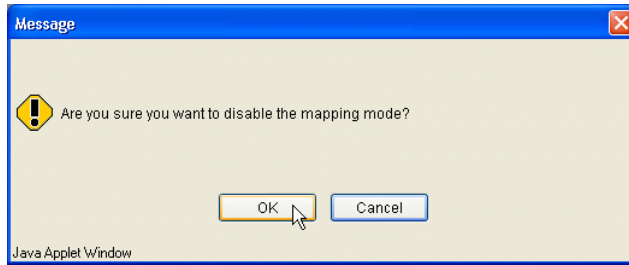

Mapping Guard

Mapping guard is a function to protect mapping setting against erroneous operation. Users cannot do mapping operation on Navigator 2 to the logical unit on which mapping guard is set to effective.

To enable or disable Mapping Guard:

1. Select **Mapping Guard** icon in the tree view.
2. Click **Set**.

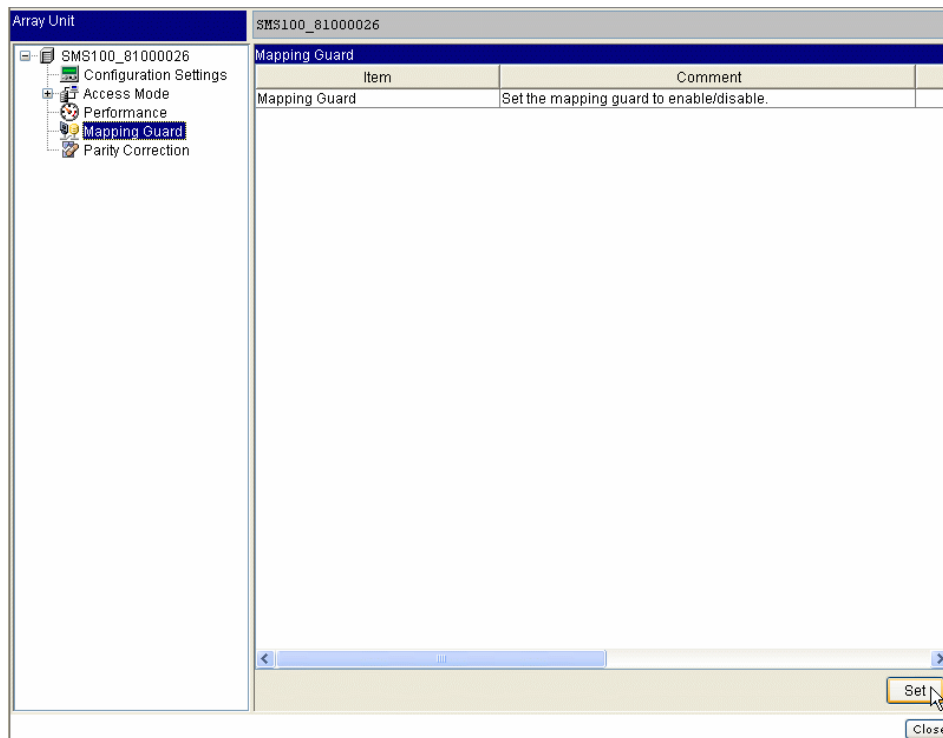

The **Mapping Guard** dialog displays.

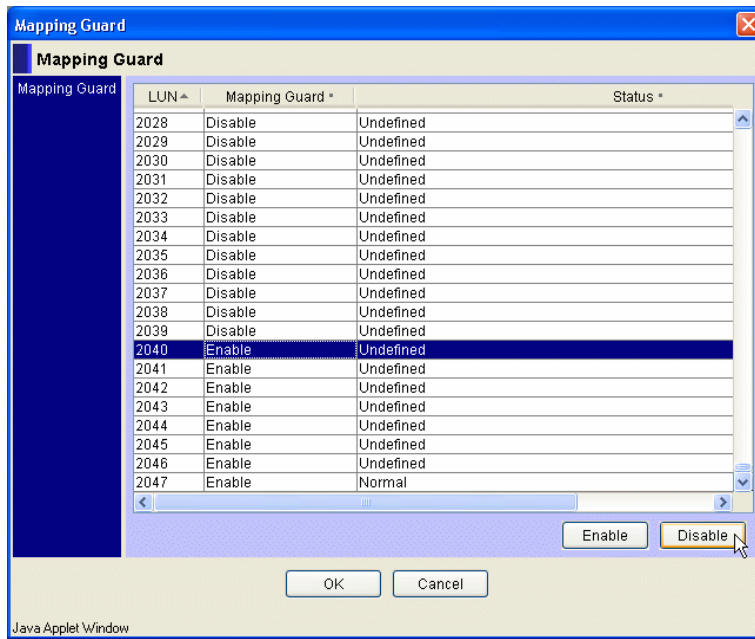

3. Select a **LUN**.
4. Click **Enable** or **Disable**.
5. Click **OK**.
6. A confirmation message displays. Click **OK**.

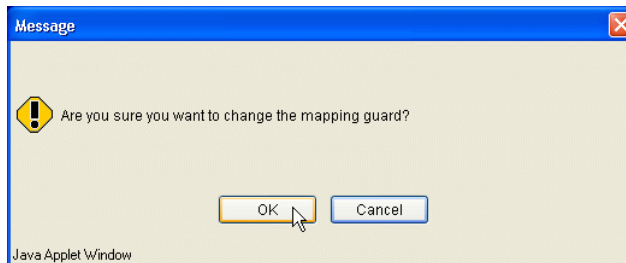

Parity Correction

Restore the logical unit in which the parity error occurred. From the status of the logical unit, you can determine if a parity error has occurred.

1. Select **Parity Correction** icon in the tree view.
2. Click **Parity Correction**.
3. Select the logical unit to which you want to correct parity.

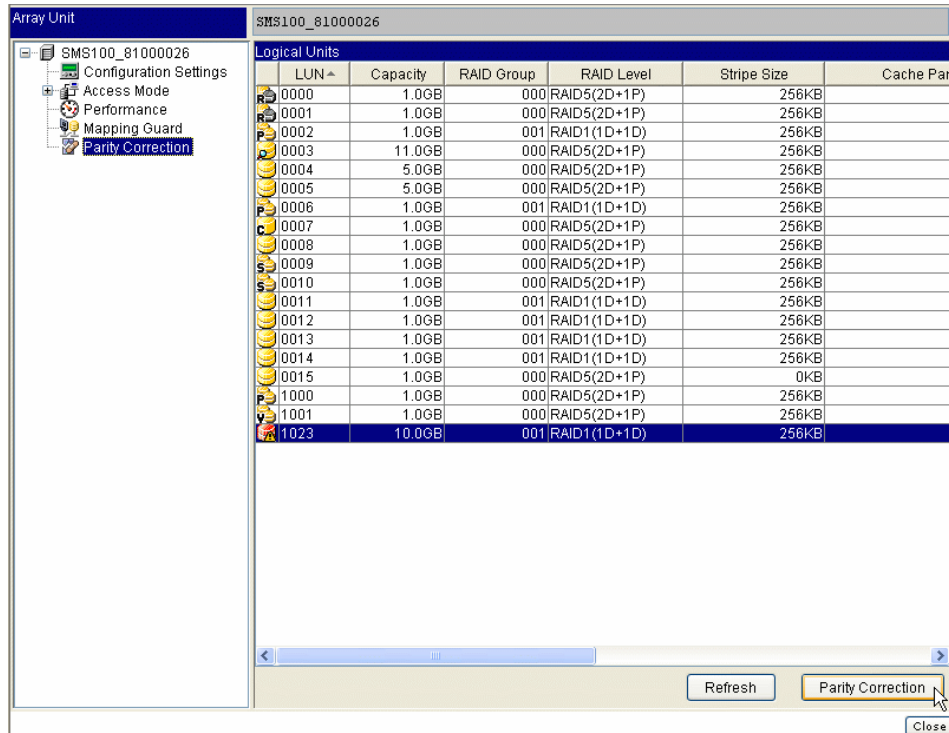

The unconnected logical units list displays.

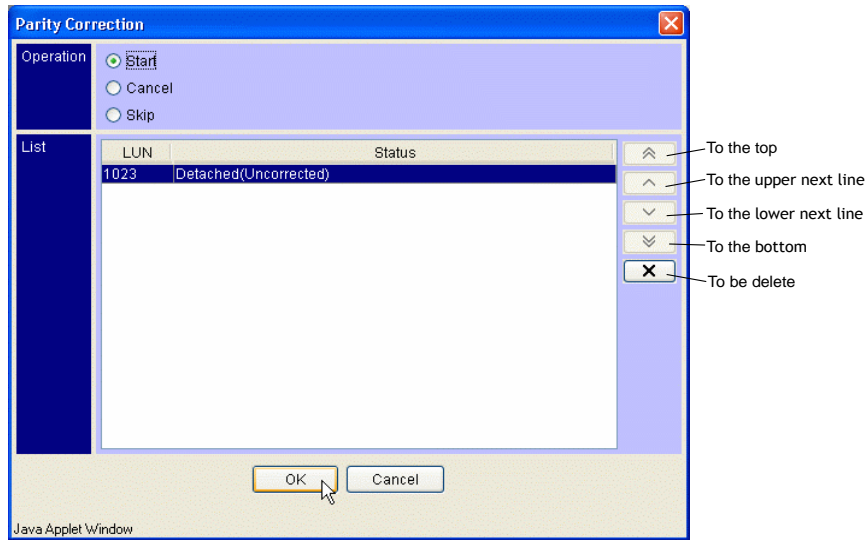

4. Change the order of the restoration process, when necessary.
(The logical unit listed at the top is processed first.)
5. To continue, click **Start**, and then click **OK**. (Or to cancel, click **Skip** and click **OK**.)
6. A message displays. Click **OK**.

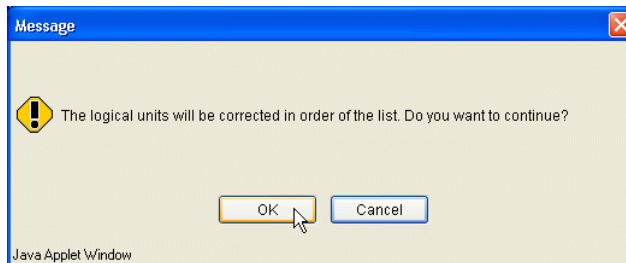

7. A message displays stating that the parity correction has started. Click **OK**.

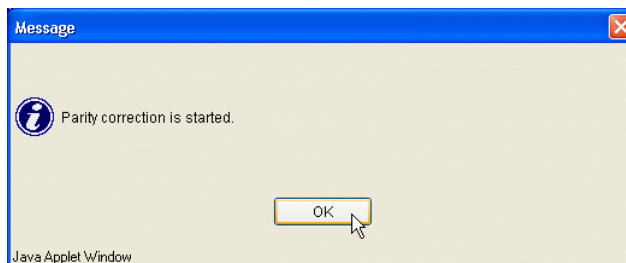

Navigator 2 only directs the process being performed. The array firmware performs the specific operation.

Hitachi Storage Navigator Modular 2 on 9500VIAMS/WMS Arrays

This chapter describes how to use Navigator 2 to manage the legacy Hitachi storage systems 9500V and AMS/WMS.

This chapter contains the following:

- Definition of RAID Group/Logical Unit
- Configuring Array Unit
- Setting Host Group Information
- Setting Target Information
- Setting System Parameters
- Configuring NNC
- Displaying Statistical Information
- Acquiring Performance Information
- Tuning Parameters
- ACE Tool

To use Navigator 2 with the 9500V or AMS/WMS:

1. Start Navigator 2.
2. Log in as registered user to Navigator 2.
3. Add the 9500V or AMS/WMS arrays. For more detailed see Navigator 2 online help.
4. Select array and click **Show & Configure Array**.
5. Select **Advanced Settings** icon in the **Settings** tree view.
6. Click **Open Advanced Settings**.

After a few minutes, an Array Unit (Applet) screen displays.



Note: The Applet screen is displayed connected to the **SNM2 Server**. If 20 minutes elapses while displaying the Applet screen, you will not be able to operate it due to the automatic logoff function.

If the operation is completed, close the screen. If the Applet screen cannot be displayed, the login to the **SNM2 Server** may have failed. In this case, the Applet screen cannot be displayed again. The code:

0x000000000000b045 or "DMEG800003: The error occurred in connecting RMI server." is displayed on the Applet screen. Take the following actions.

Close the Web browser, stop the **SNM2 Server** once, restart it, and display the screen of the Array you want to operate.

- Close the Web browser; confirm the **SNM2 Server** is started. If it has stopped, start it and display the screen of the Array that you want to operate.
- Return to the Array screen after 20 minutes elapsed and display the screen of the Array you want to operate.

On the Array Unit screen, the status of the array unit system components and configuration information of logical units, etc. displays selectively by switching the tab. For example, the following screen displays a connection with a AMS/WMS subsystem.

Navigator 2 Version: Less than 5.00

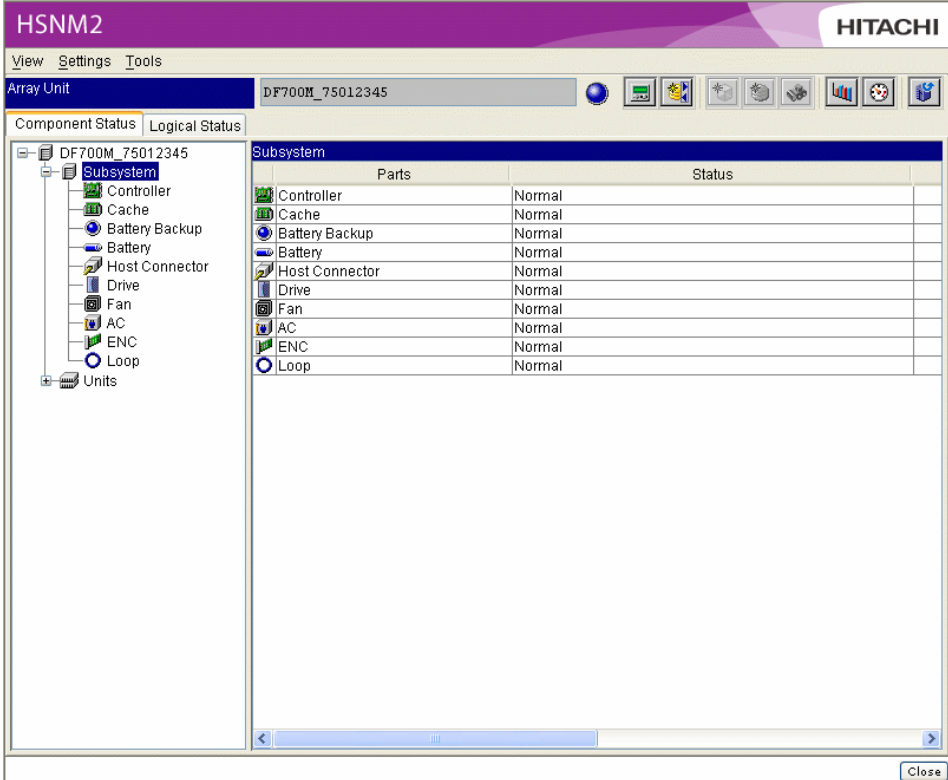

Navigator 2 Version: More than 5.00

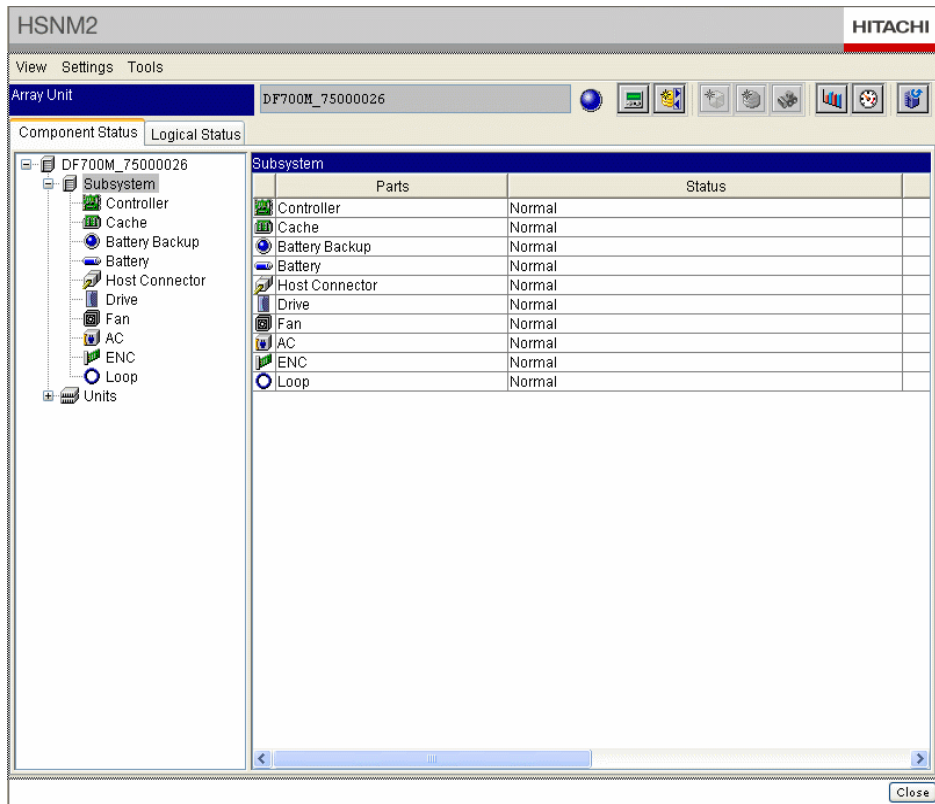



Menu and Tool Bars

The following sections contain examples of the various icons and objects that display on Array Unit screen.





View:

Menu	Tool bar	Function
Properties	—	Displays the property of the subsystem.
Drive Configuration	—	Displays the drive configuration of the subsystem.
Refresh		Refreshes the Array Unit screen.

Settings:

Menu		Tool bar	Function
RAID Group	Create		Displays the RAID group settings screen.
	Delete	—	Delete specified RAID group.
Logical Unit	Create		Displays the logical unit settings screen.
	Format		Formats the logical unit (Max.6).
	Change Default Controller	—	Changes default controller of the logical unit.
	Parity Correction	—	Corrects the logical unit parity.
	Delete	—	Deletes specified logical unit.

Tools:

Menu	Tool bar	Function
Wizard		Starts the logical unit wizard.
Configuration Settings		Displays the configuration settings screen.
Mapping Guard	—	Display the LU mapping guard settings screen.
Performance Output File		Outputs the performance of the subsystem.
Settings	—	Sets the collection of performance statistics.
Statistical Information		Displays the statistics information of the subsystem.
Information Message	—	Displays the information message of the subsystem.
Tuning Parameter	—	Displays the tuning parameter screen.
ACE Tool	—	Navigates the Back-end configuration.

Pop-Up (Right-Click) Menus

The pop-up menus are context-sensitive and display when you click the right mouse button on the Array Unit screen (**Logical Status** tab).

The following figure shows the pop-up menu that displays when a RAID group number is selected on the Array Unit screen.

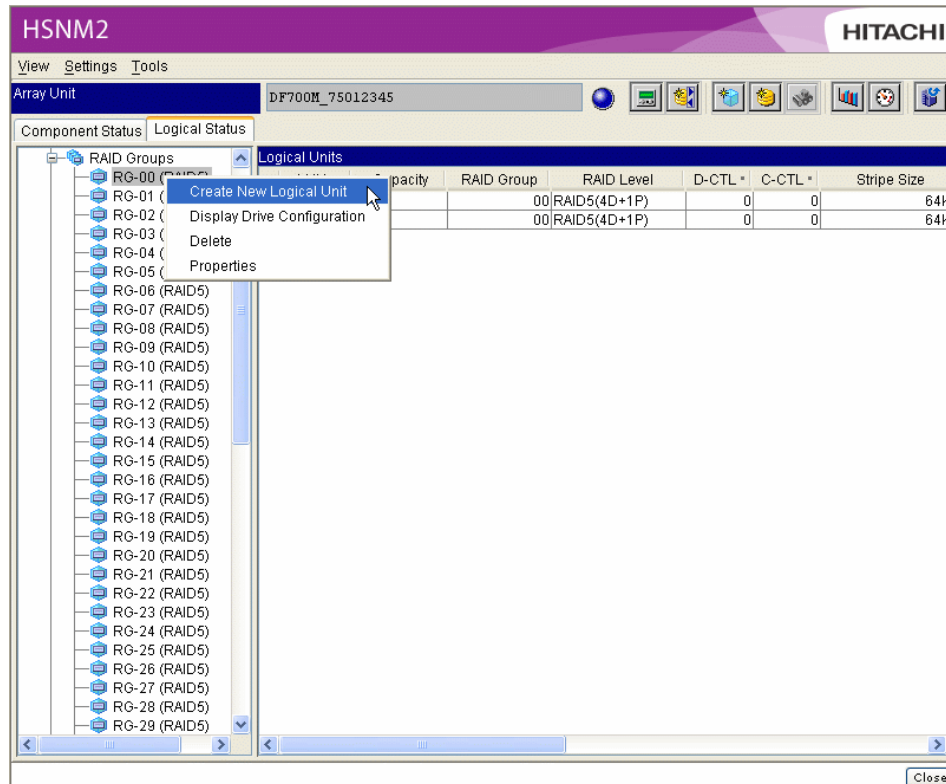

The following table describes the pop-up menu options.

Selection	Menu	Function
RAID group number icon	Create New Logical Unit	Display the property dialog box for creating a new logical unit.
	Display Drive Configuration	Display the drive configuration of the subsystem.
	Delete	Delete the selected RAID group.
	Properties	Display the property of the RAID group.

The following figure shows the pop-up menu that displays when **RAID Groups** is selected on the Array Unit screen.

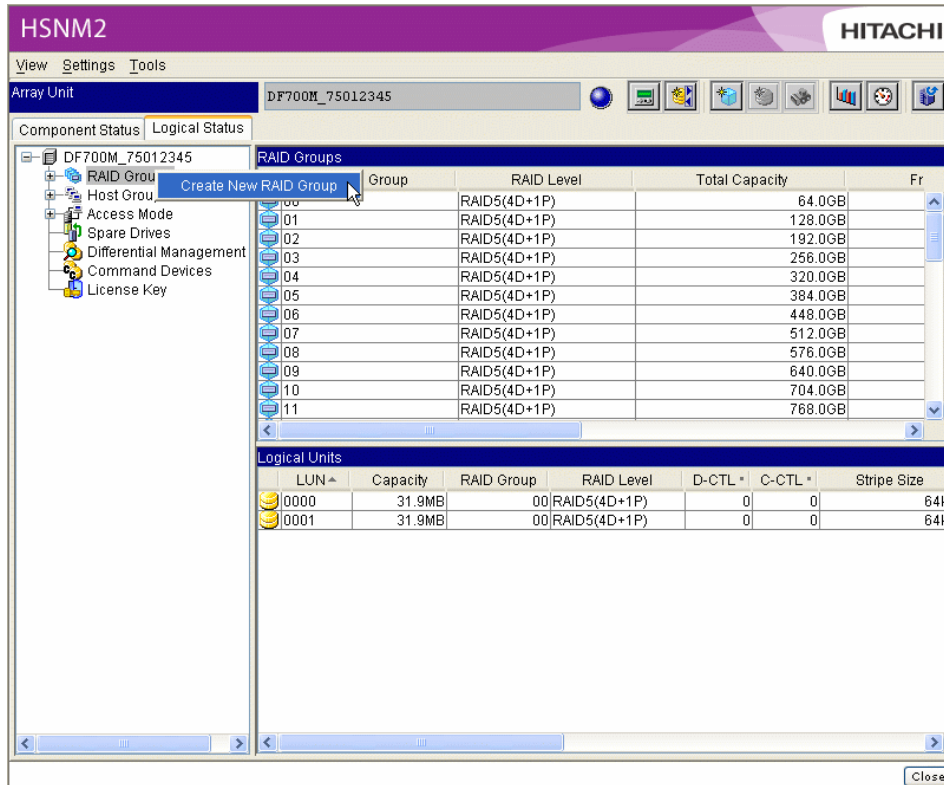

The following table describes the pop-up menu options.

Selection	Menu	Function
RAID Groups	Create New RAID Group	Display the RAID group settings screen.

The following figure shows the pop-up menu that displays when one logical unit icon is selected on the Array Unit screen.

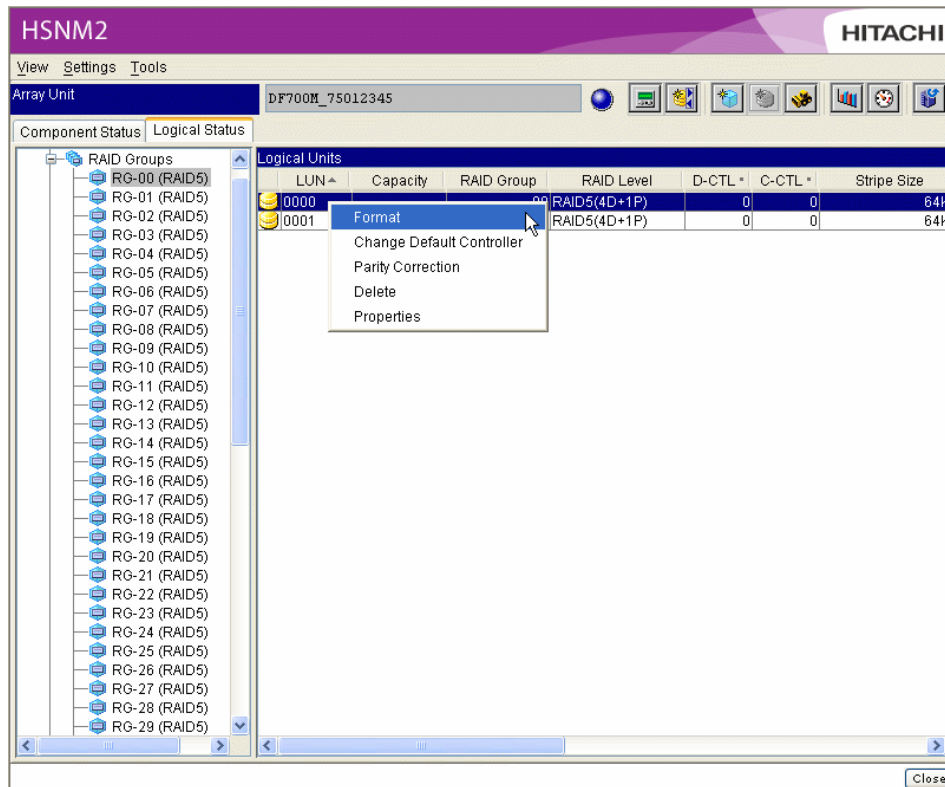

The following table describes the pop-up menu options.

Selection	Menu	Function
Logical unit icons (one)	Format	Format the logical units.
	Change Default Controller	Change default controller of logical unit.
	Parity Correction	Correct the logical unit parity.
	Delete	Delete the selected logical unit.
	Properties	Display the property of the logical unit.

The following figure shows the pop-up menu that displays when multiple logical unit icons are selected on the Array Unit screen.

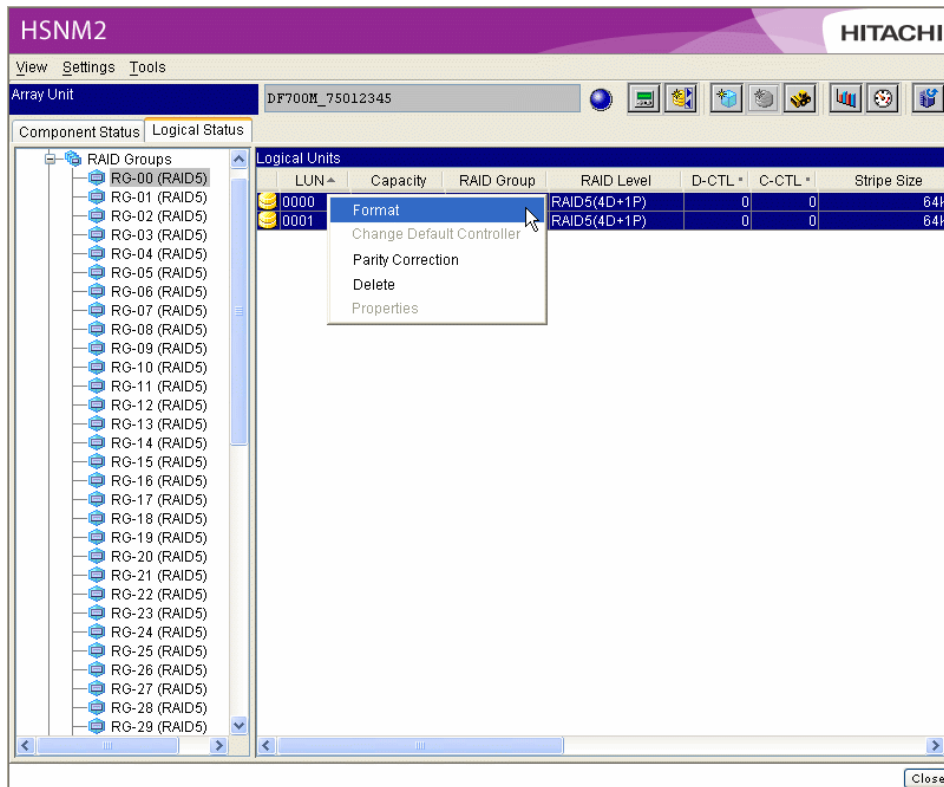

The following table describes the pop-up menu options.

Selection	Menu	Function
Logical unit icons (two or more)	Format	Format the logical units (maximum 6).
	Parity Correction	Correct the logical unit parity.
	Delete	Delete the selected logical unit.

The following figure shows the pop-up menu that displays when a drive icon is selected on the Array Unit screen.

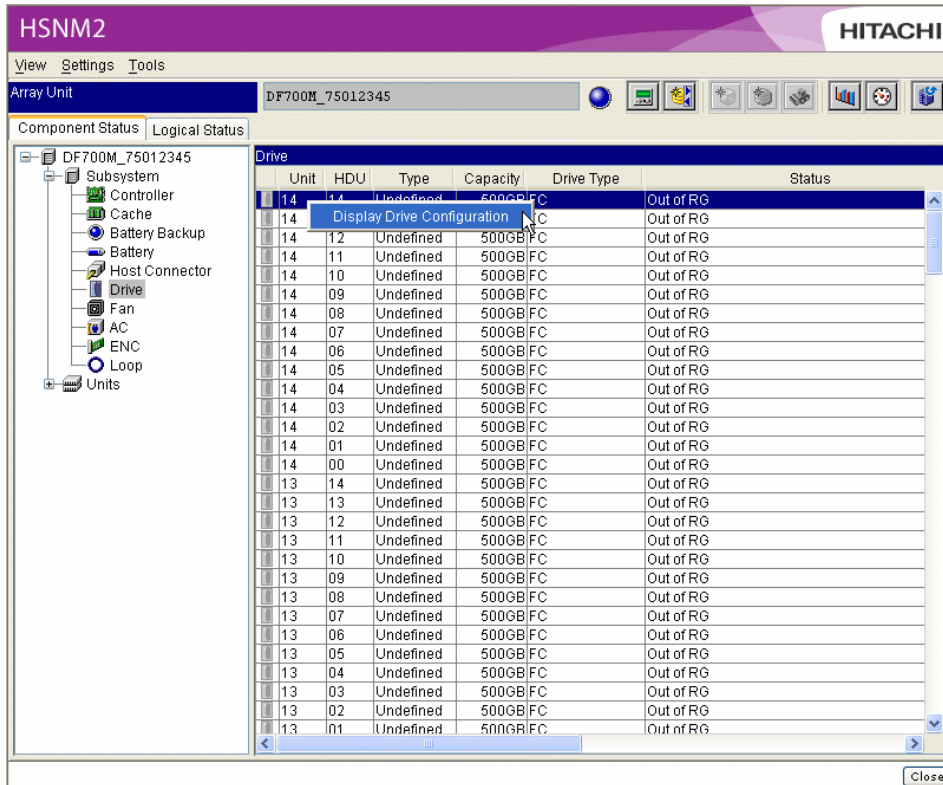

The following table describes the pop-up menu options.

Selection	Menu	Function
Drive icon	Display Drive Configuration	Display the drive configuration of an array unit.

Displaying Status and Properties of Array Unit and Components

- To update the component display, on the **View** menu, select **Refresh** or click .
- To display component status and properties, select the component in the **Component Status** tab.
- To display the properties of the subsystem, on the **View** menu, select **Properties**. The **Property** screen displays the following information. See following figure.

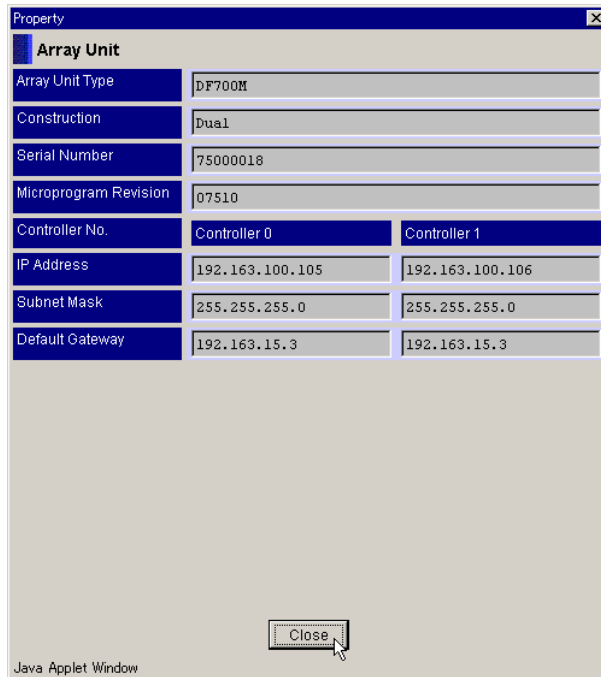

- **Array Unit Type:** Subsystem type
- **Construction:** Subsystem configuration type
- **Serial Number:** Subsystem serial number
- **Microprogram Revision:** Subsystem firmware revision
- Controller No.
- **IP Address:** IP address of each controller
- **Subnet Mask:** Subnet Mask of each controller
- **Default Gateway:** Default gateway of each controller

Displaying Array Unit Configuration Information

To display array unit configuration information:

1. On the **Tools** menu of the **Array Unit** window, select **Configuration Settings** or click .
2. Click the **LAN** tab.

The LAN configuration displays the information that is validated in the subsystem. See following figure.

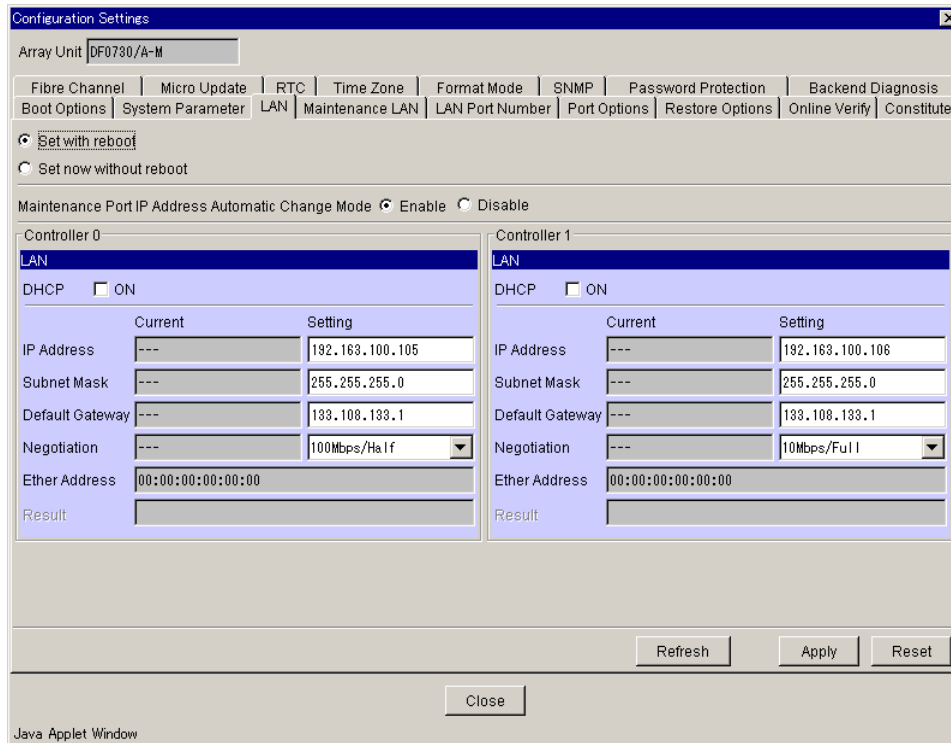

Displaying an Information Message

To display the **Information Message** dialog box, see following figure.

Double click a patrol lamp icon (🔦) in the **Array Unit** Screen.

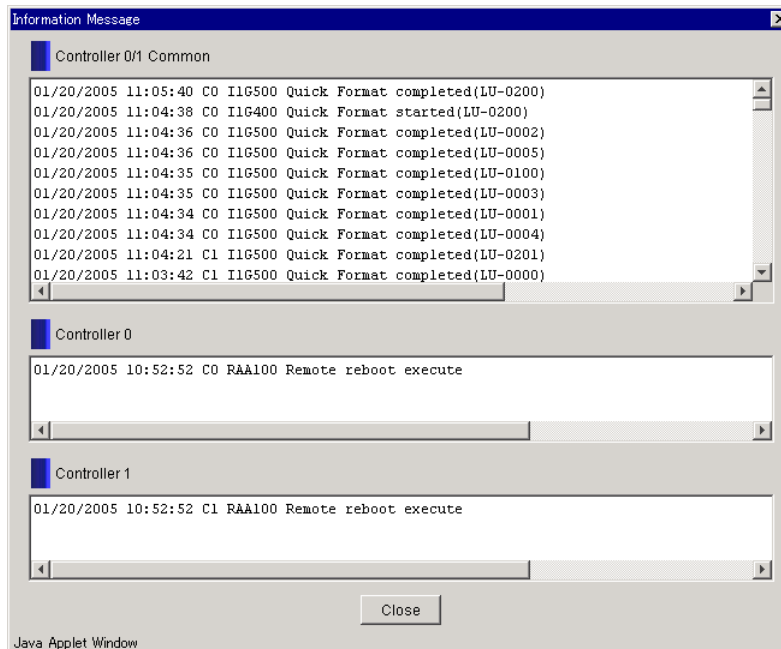

- **Controller 0/1 Common:** After the array unit starts, the fault information and status information displays in the **Controller 0/1 Common** box.
- **Controller 0:** As the array unit starts, the fault information and status information displays in the box of Controller 0.
- **Controller 1:** As the array unit starts, the fault information and status information displays in the box of Controller 1.

Definition of RAID Group/Logical Unit

Displaying RAID Group/Logical Unit Definition

1. Click the **Logical Status** tab on the Array Unit screen.

The screenshot shows the HSNM2 interface for array unit DF700M_75012345. The 'Logical Status' tab is selected. The left sidebar shows a tree view with 'RAID Groups' expanded. The main area displays two tables:

RAID Group	RAID Level	Total Capacity	Fr
00	RAID5(4D+1P)	64.0GB	
01	RAID5(4D+1P)	128.0GB	
02	RAID5(4D+1P)	192.0GB	
03	RAID5(4D+1P)	256.0GB	
04	RAID5(4D+1P)	320.0GB	
05	RAID5(4D+1P)	384.0GB	
06	RAID5(4D+1P)	448.0GB	
07	RAID5(4D+1P)	512.0GB	
08	RAID5(4D+1P)	576.0GB	
09	RAID5(4D+1P)	640.0GB	
10	RAID5(4D+1P)	704.0GB	
11	RAID5(4D+1P)	768.0GB	

LUN	Capacity	RAID Group	RAID Level	D-CTL	C-CTL	Stripe Size
0000	31.9MB	00	RAID5(4D+1P)	0	0	64K
0001	31.9MB	00	RAID5(4D+1P)	0	0	64K

This figure displays the definition information of all RAID groups and all logical units defined in the array unit:

- **RAID Groups:** Information about all RAID groups defined for an array unit displays for each RAID group.
 - **Logical Units:** Information about all logical unit number (LUN) defined for an array unit displays for each LUN.
2. To display the relation of the RAID group that defines the logical unit and a drive, select **Drive Configuration** on the **View** menu.

The **Drive Configuration** dialog displays.

3. When you click the RAID group number icon, the RAID level is highlighted on the icon for the drive that composes the RAID group. The displayed RAID level overlaps the icon.

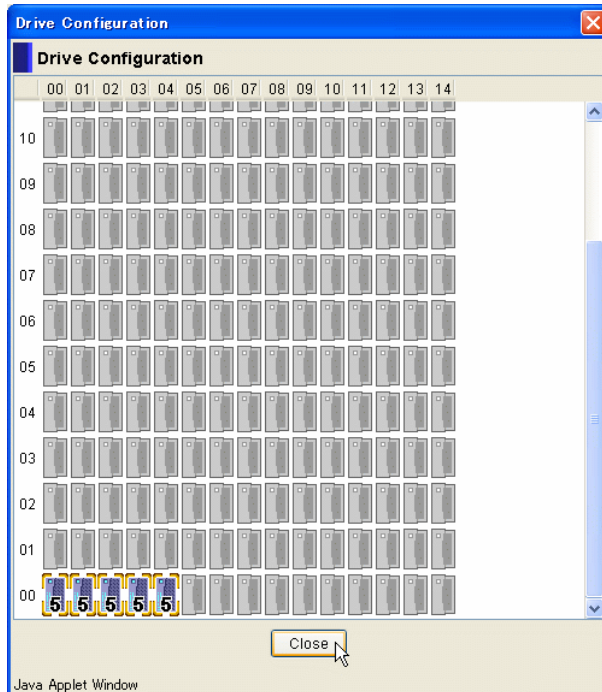

Creating a RAID Group Automatically

To create a new RAID group by selecting the drives automatically:

1. Click the **Logical Status** tab on the **Array Unit** screen.
2. On the **Settings** menu of the **Array Unit**, select **RAID Group**, then click **Create**, or click .

You can also complete this operation from the context menu of the **RAID Groups** icon.

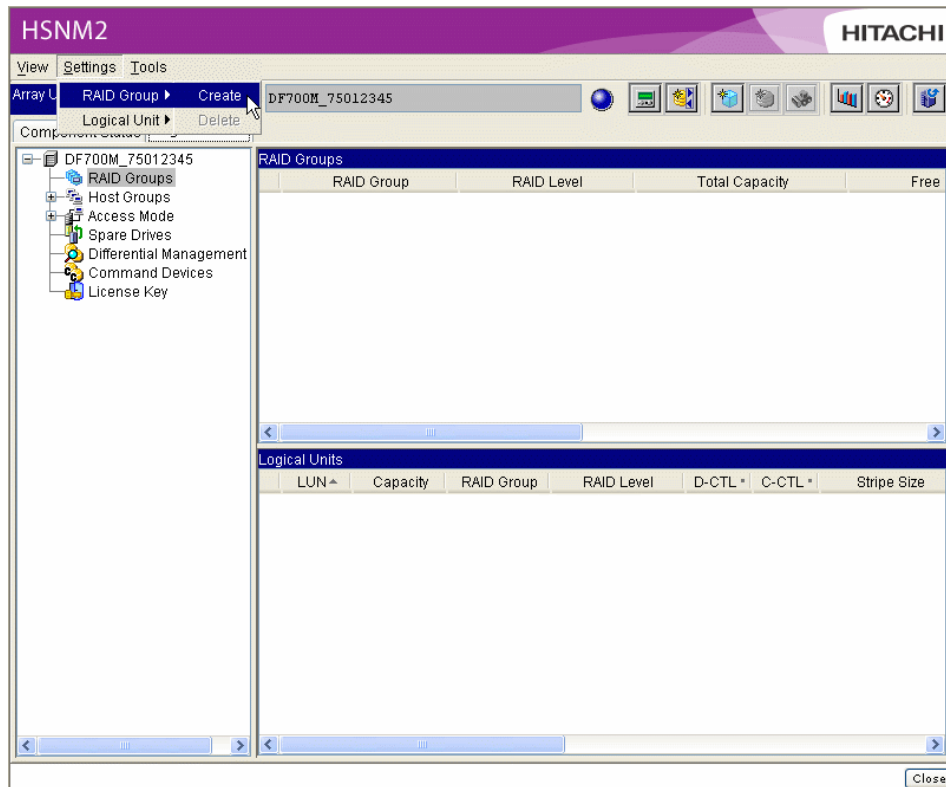

The **Create RAID Group** dialog displays. See following figure.

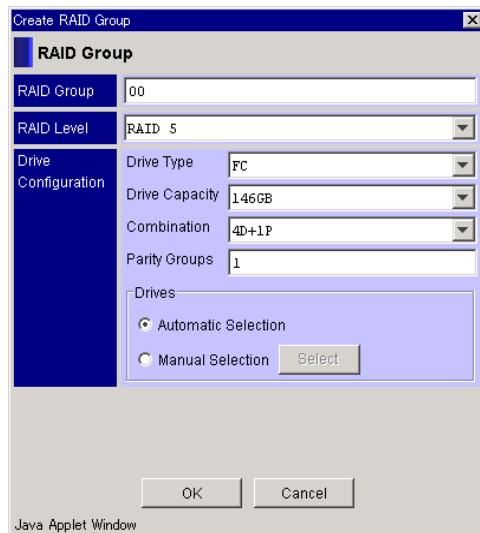

3. Select and/or enter a **RAID Level** and **Drive Configuration** which includes the **Drive Type**, **Drive Capacity**, **Combination**, and **Parity Groups**, then click **OK**.
4. Click **OK** as needed to continue and to respond to the confirmation messages. Clicking **OK** updates the set RAID group and displays following figure.

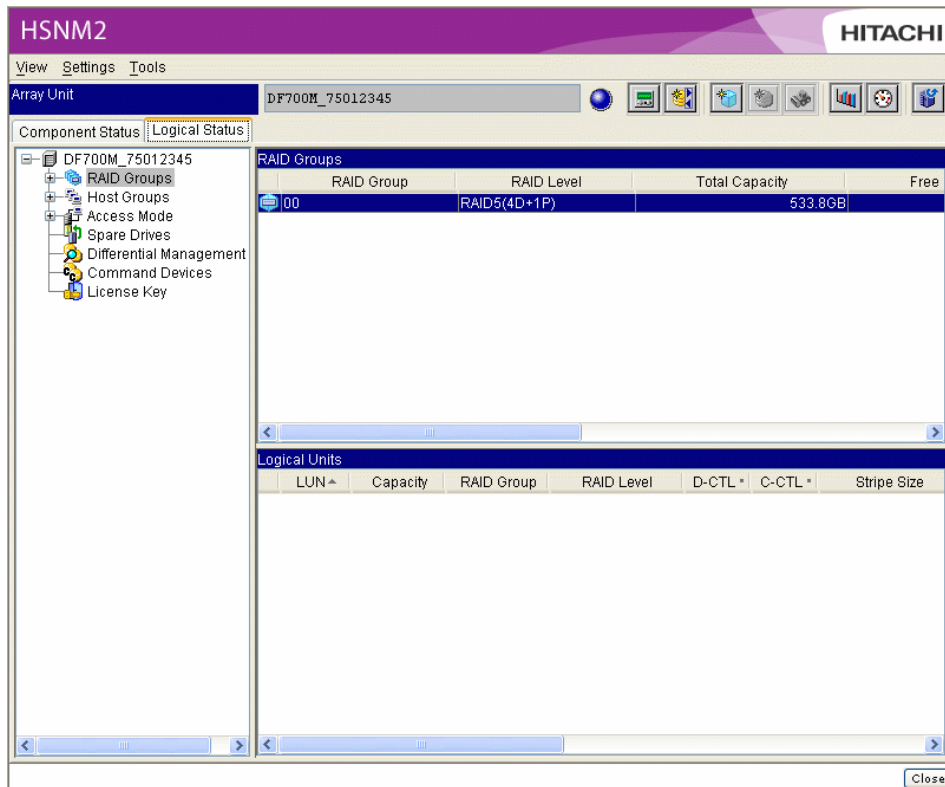

Creating a RAID Group Manually

To create a new RAID group by selecting the drives manually:

1. Click the **Logical Status** tab on the **Array Unit** screen.
2. On the **Settings** menu of the **Array Unit**, select **RAID Group**, then click **Create**, or click .

You can also complete this operation from the context menu of the **RAID Groups** icon.

The **Create RAID Group** dialog displays. See following figure.

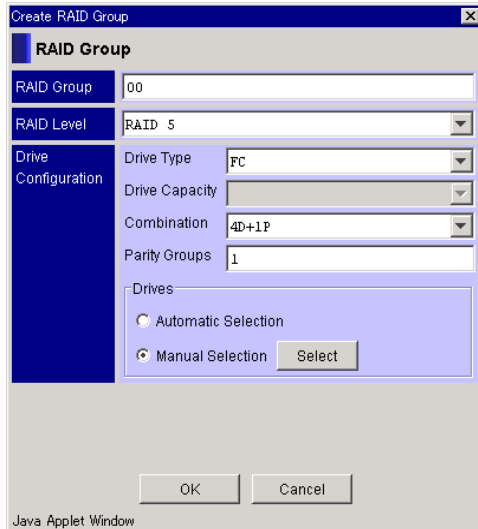

3. Enter the settings in the **Create RAID Group** dialog box.
4. In **Drives**, in the Select Drives dialog box, select the **Manual Selection** option, and click **Select**. See following figure.

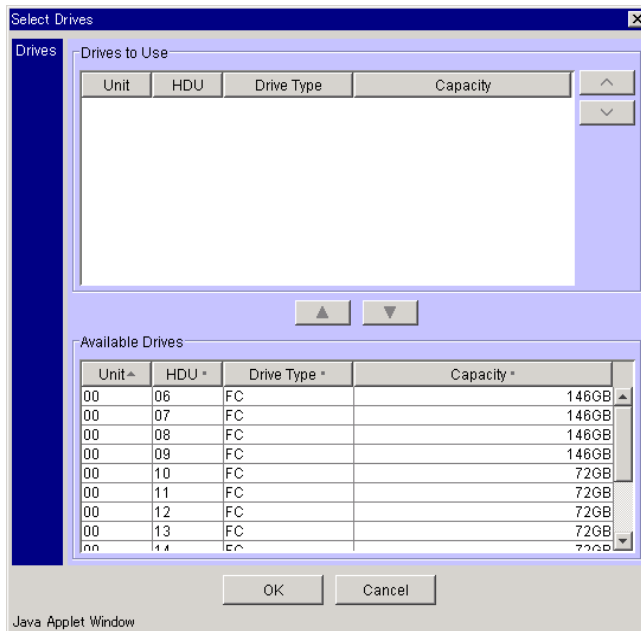

5. In **Available Drives** list, click the **HDU** number.
6. Click the HDU number to compose a RAID group, keeping the **Shift** key pressed.
7. Click .

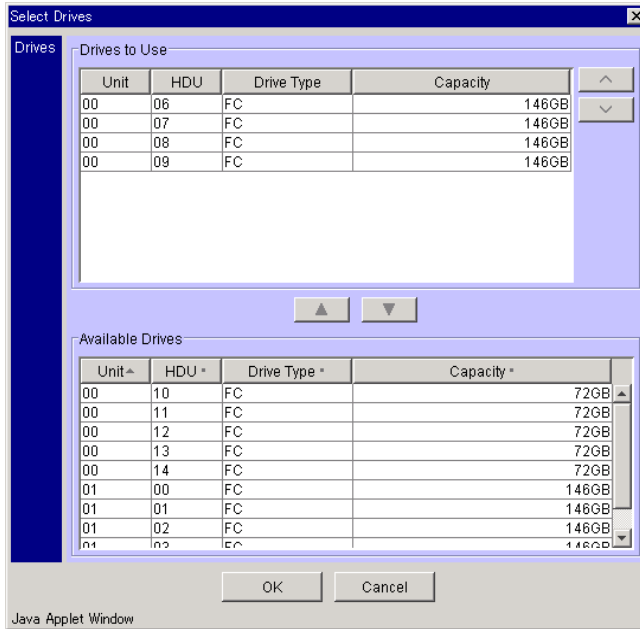

- Click **OK** as needed to continue and to respond to messages.
Clicking **OK** updates the set RAID group and displays following figure.

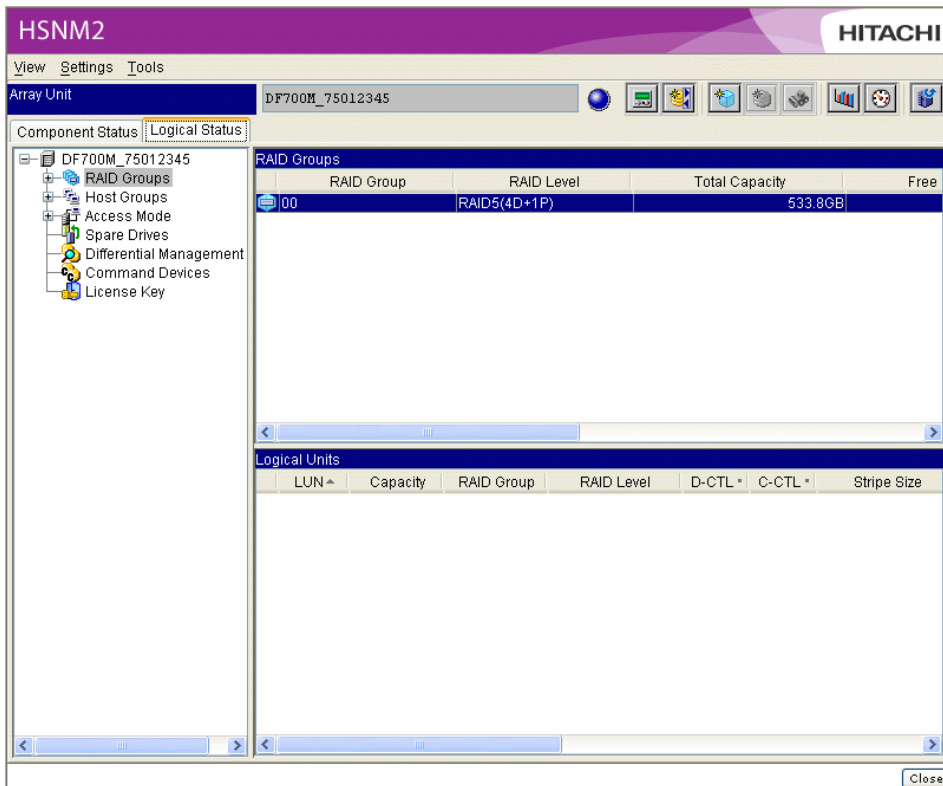

Deleting a Specified RAID Group

To delete a specified RAID group from set RAID groups:

1. Click the **Logical Status** tab on the **Array Unit** screen.
2. Click the icon of a RAID group on the **Array Unit** screen.
To delete more than one RAID group, select additional groups while pressing the **Shift** key.
3. On the **Settings** menu of the **Array Unit** screen, select **RAID Group** and click **Delete**.
4. To continue through warning or status messages, click **OK** or **Close**.



Note: If a logical unit is defined in the RAID group, all of the user data is invalidated by deleting the RAID group.

If a logical unit that cannot be deleted is defined in the specified RAID group, this RAID group cannot be deleted. To delete the specified RAID group, first release the settings on all logical units in the specified RAID group, and then delete the RAID group.

Constituting a Logical Unit Automatically

1. Click the **Logical Status** tab on the **Array Unit** screen.
2. Click the icon of the desired RAID group to create a logical unit.
3. On the **Settings** menu, select **Logical Unit** and click **Create**, or click . See following figure.
You can also complete this operation from the context menu of the RAID group number icon.

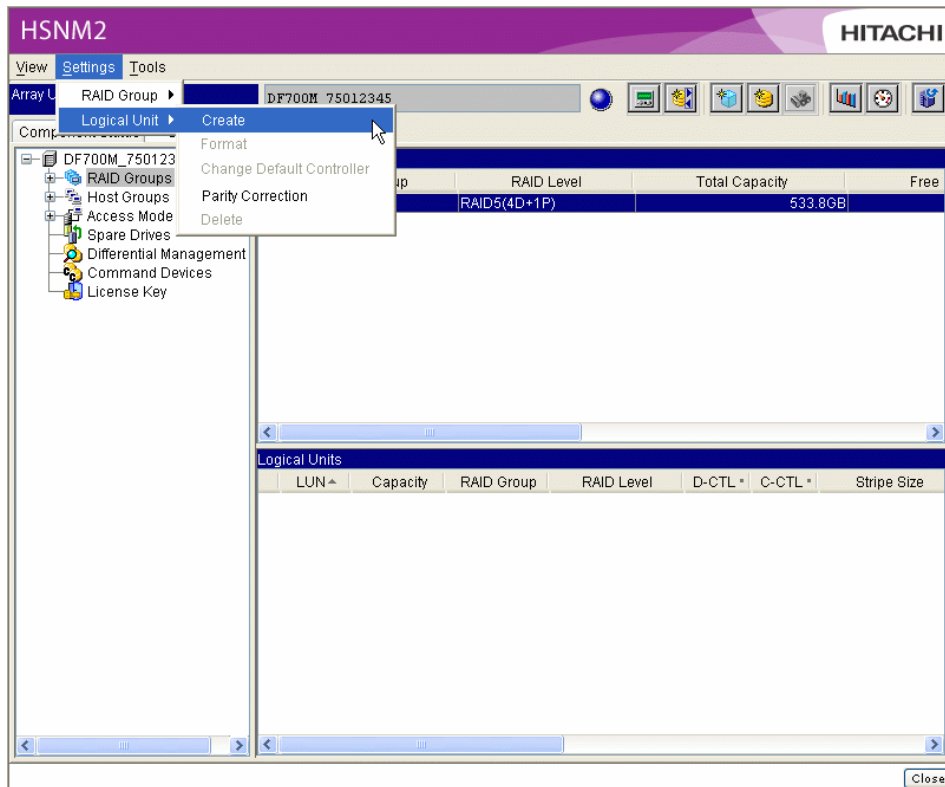

The **Create Logical Unit** dialog displays. See following figure.

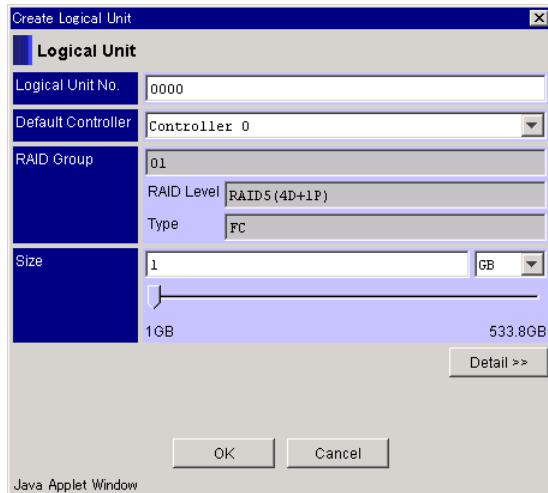

4. Select a **Logical Unit No.**, **Default Controller**, and input **Size**.

A created logical unit number displays the **Logical Unit No.** and RAID group number and displays the logical units that are defined for the **RAID Group**. Additionally, a logical unit capacity that can be created displays.

- Specify Number of **Block**, **MB**, or **GB** Increased.

To specify a value clearly, specify the allocation (number of blocks, MBs, or GBs). When you allocate all of the remaining capacity of the designated RAID group, specify a capacity displayed on the screen.

**Note:**

When the capacity of a logical unit is specified by GB or MB and the capacity is specified as the rightmost value of the slider, a logical unit with the whole free capacity of the RAID group to which the logical unit belongs is created. When a fractional capacity is included in the free capacity, a logical unit with a capacity that includes it is created. (You can see whether the free capacity has a fractional portion by viewing the Free Capacity field.) When you want to create a logical unit that does not have a fractional capacity, specify the logical unit using the other unit.

The relation between MB and blocks is: 1 MB = 2,048 blocks. A fraction less than 2,048 blocks is omitted. The relationship between GB and MB is 1 GB = 1,024 MB. A fraction less than 1,023 MB is omitted.

Example: 2,048,000 blocks = 1,000 MB
 2,049,024 blocks = 1,000 MB

- Specify the **Controller No.**

Select **Controller 0** or **Controller 1** to select the controller in charge of the logical unit. If you select the wrong controller, the logical unit can unexpectedly switch during operation. Performance quality may deteriorate as a result.

This is necessary with a dual system connection. It is not displayed with a single system connection.



Note: When dual active mode is selected in the dual system, the controller in charge of a logical unit must be selected to set up the logical unit. Perform the logical unit setting, including the selection of the controller that is referred to following figure.

Example:

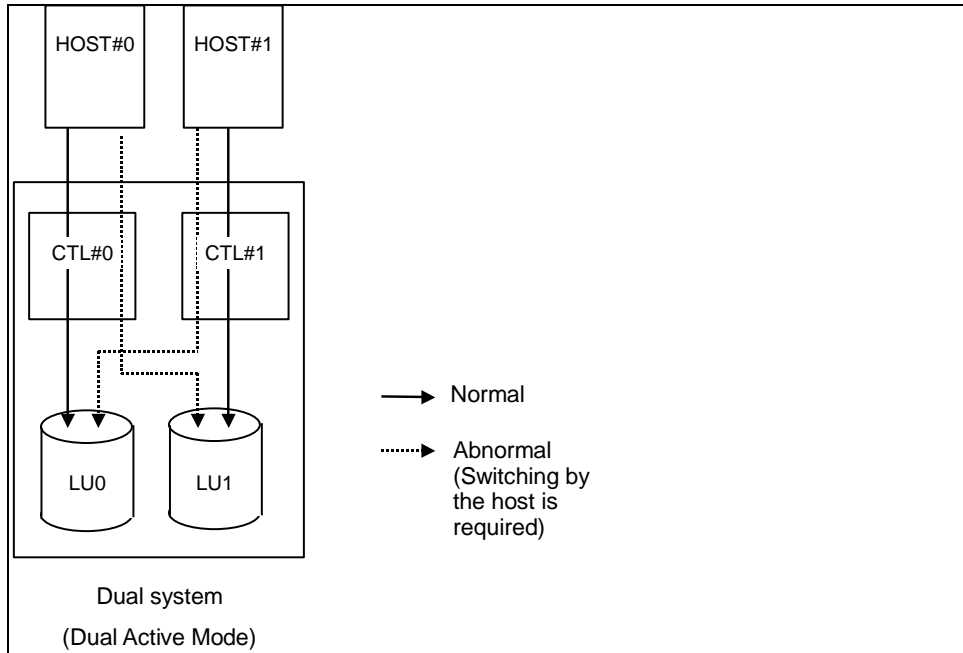

- **Dual Active Mode:** Select a controller to access from the host to the logical unit as the controller for the logical unit.

In above figure, CTL#0 is in charge of logical unit0 and CTL#1 is in charge of logical unit1. In this example, set up the logical unit by selecting optional button **CTL#0** to select logical unit0 and button **CTL#1** to select logical unit1 respectively.

5. After setting logical unit information, click **OK**.
6. A message displays stating that the setting is complete. Click **OK**.
Clicking **OK** updates the logical unit information, and then following figure displays.

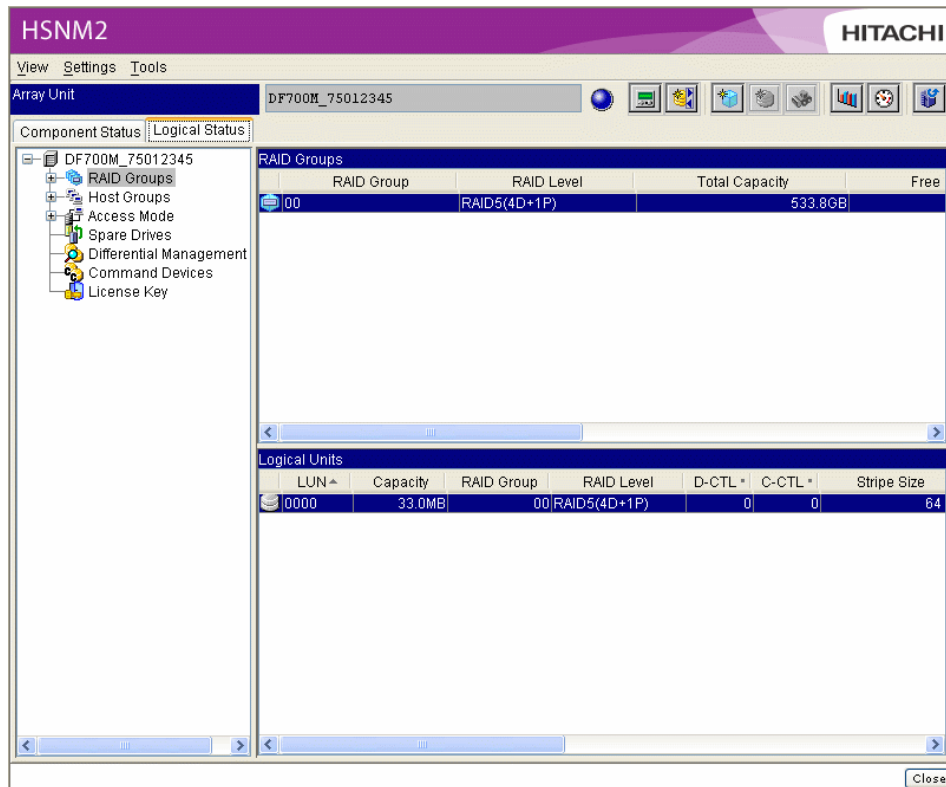

Constituting a Logical Unit Manually

1. Click the **Logical Status** tab on the **Array Unit** screen.
2. Click the icon of the desired RAID group to create a logical unit.
3. On the **Settings** menu, select **Logical Unit** and click **Create**, or click . See following figure.

You can also complete this operation from the context menu of the RAID group number icon.

You can also complete this operation from the context menu of the RAID group number icon.

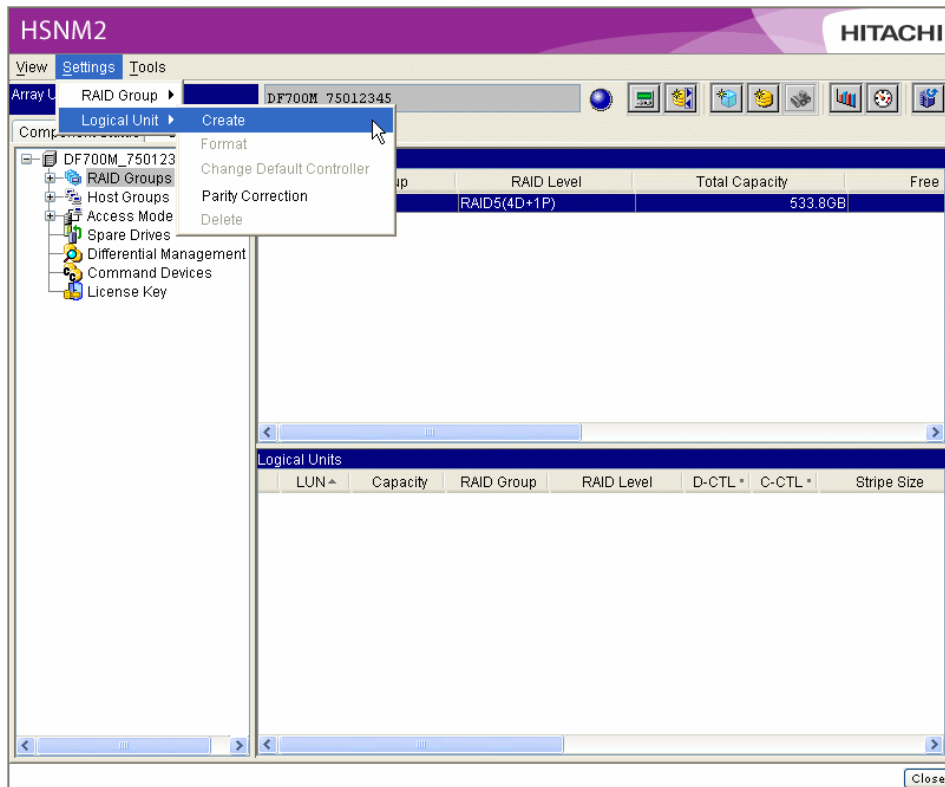

The **Create Logical Unit** dialog displays. See following figure.

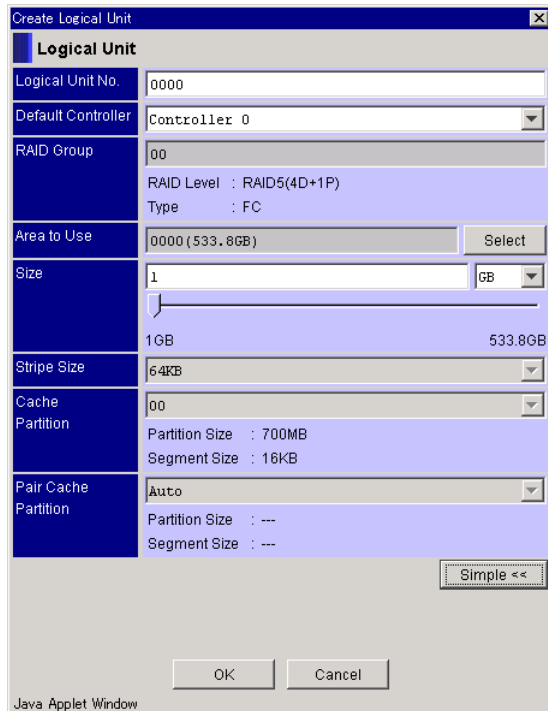

- Click **Detail**.
- Select a **Logical Unit No.**, a **Default Controller**, and the input **Size**. Click **Select**. See following figure.

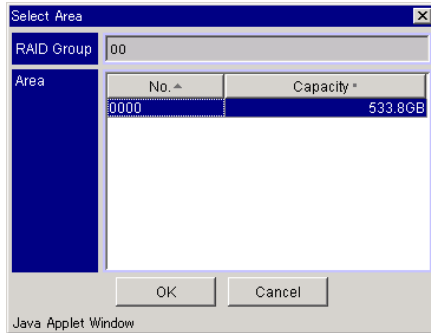

6. Select **Area** and **No.** and then click **OK**.
7. In the **Create Logical Unit** dialog box, click **OK**.
8. Click **OK** to confirm the confirmation messages.

Clicking OK updates the logical unit information and displays following figure.

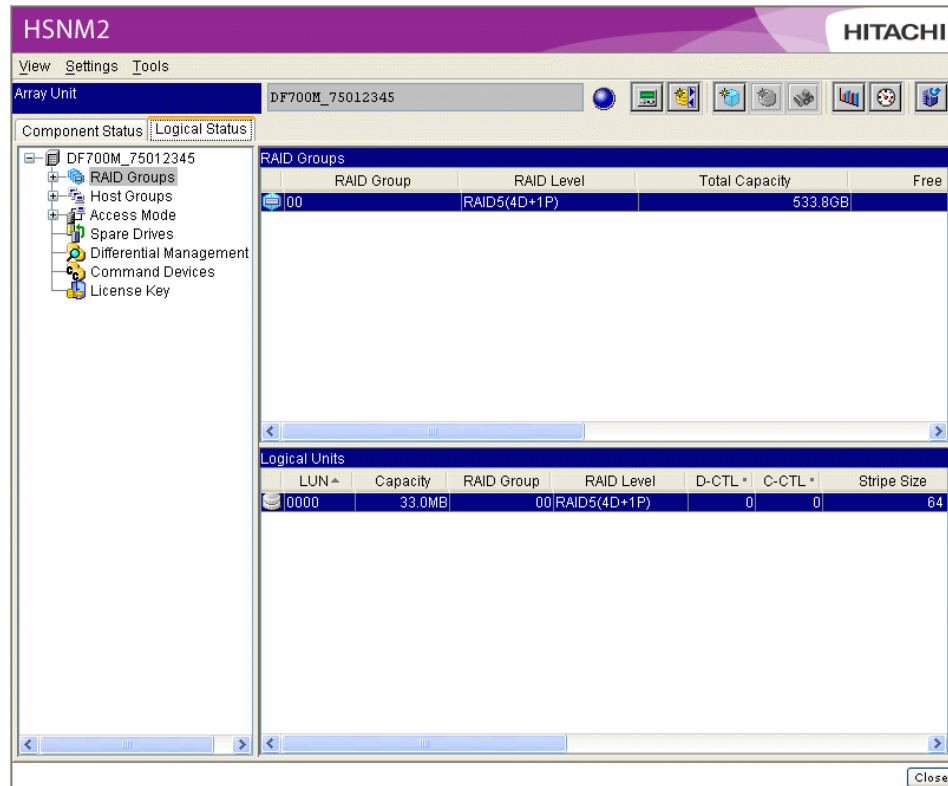

Formatting a Logical Unit

To format the logical unit:

- **Format:** Up to six logical units can be formatted concurrently per controller. A host I/O can be received even when formatting logical units.

1. Click the **Logical Status** tab on the Array Unit screen.

2. Click the logical unit icon on the Array Unit screen. On the context menu of the logical unit icon, select **Format**. See following figure.

When you select multiple logical units, hold down the **Ctrl** key and click the icons of the logical units you want to format.

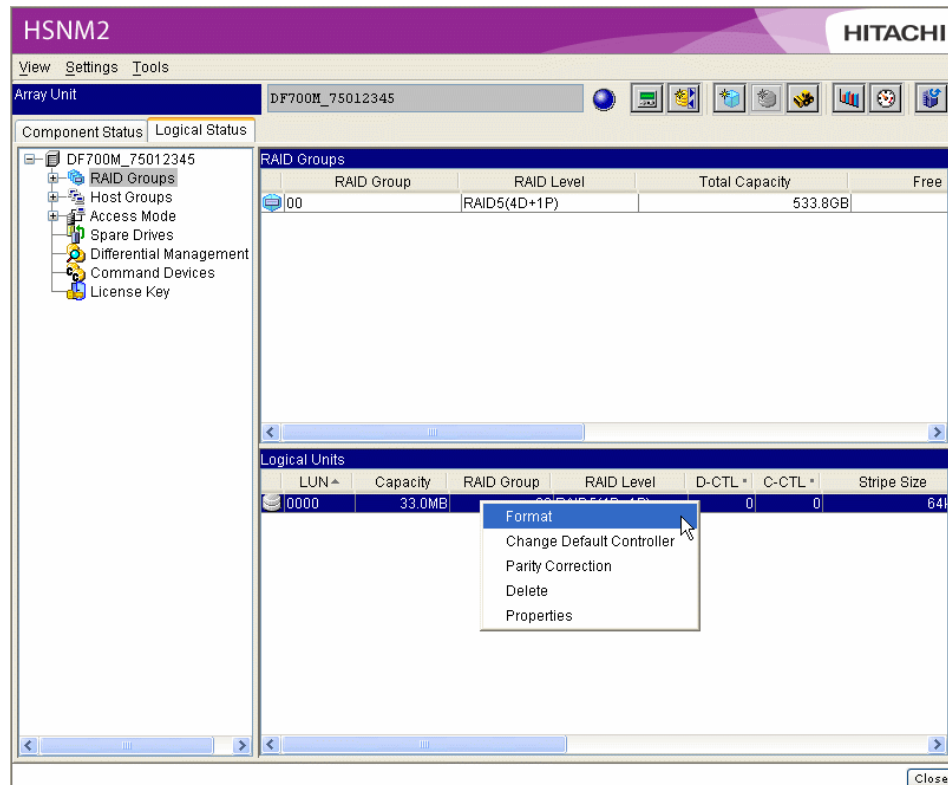

Note: The formatting may be interrupted during the following conditions:

- A host is rebooting
- I/O path switching
- Access to a logical unit of the non-ownership controller

3. To continue through warning and confirmation messages, click **OK**.

This updates the formatted logical unit information and displays following figure.

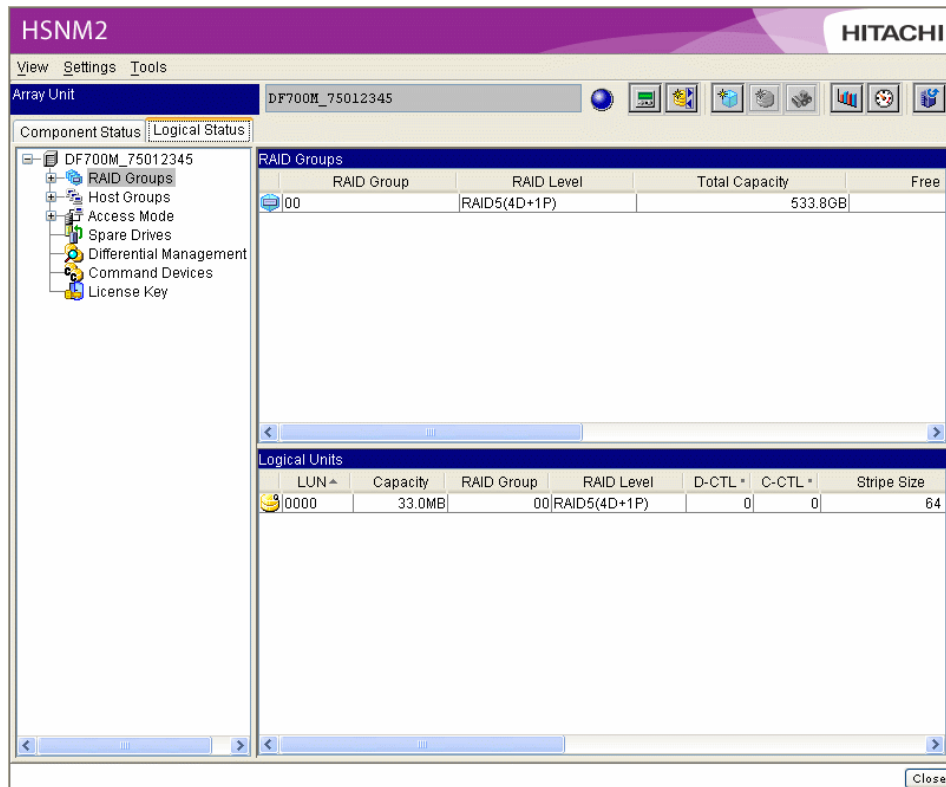

Deleting a Specified Logical Unit

To delete a specified logical unit:

1. Click the **Logical Status** tab on the **Array Unit** screen.
2. Click the logical unit icon on the **Array Unit** screen. On the context menu of the logical unit icon, select **Delete**. See following figure.

When you select multiple logical units, press the **Ctrl** key, and click the logical units icons that you want to delete.

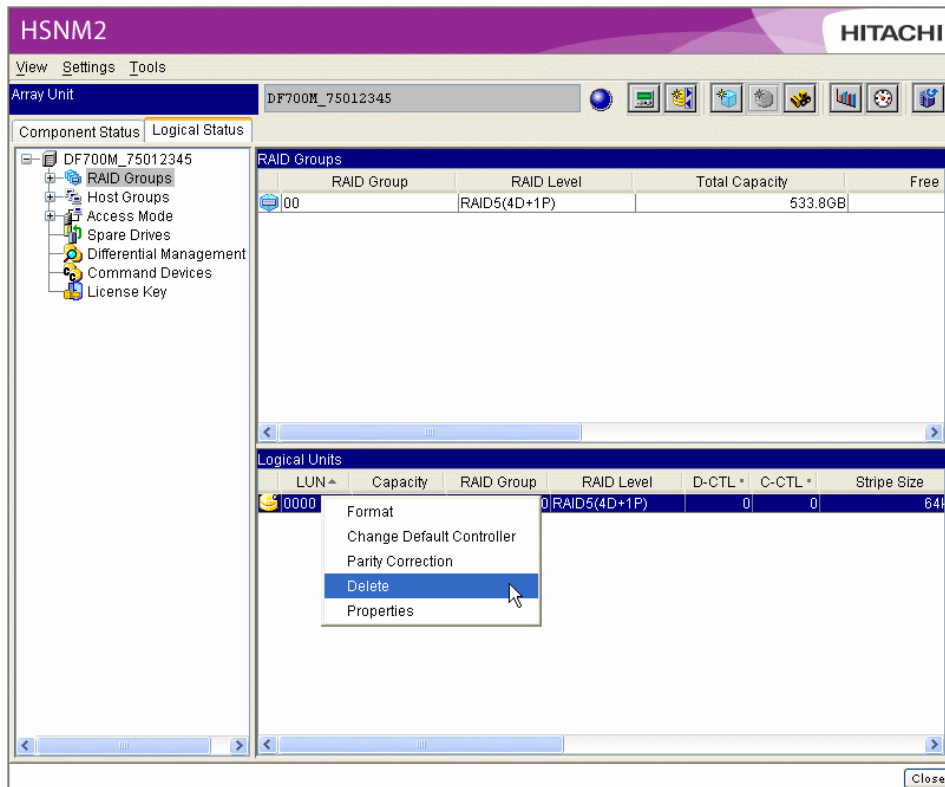

3. To continue through confirmation and status messages, click **OK** and **Close**.
The logical unit is deleted.

Changing Default Controller in Charge of a Logical Unit

To change the default controller in charge of a logical unit:

1. Click the **Logical Status** tab on the **Array Unit** screen.
2. Click the logical unit in the **Array Unit** screen. On the context menu of the logical unit icon, select **Change Default Controller**. See following figure.

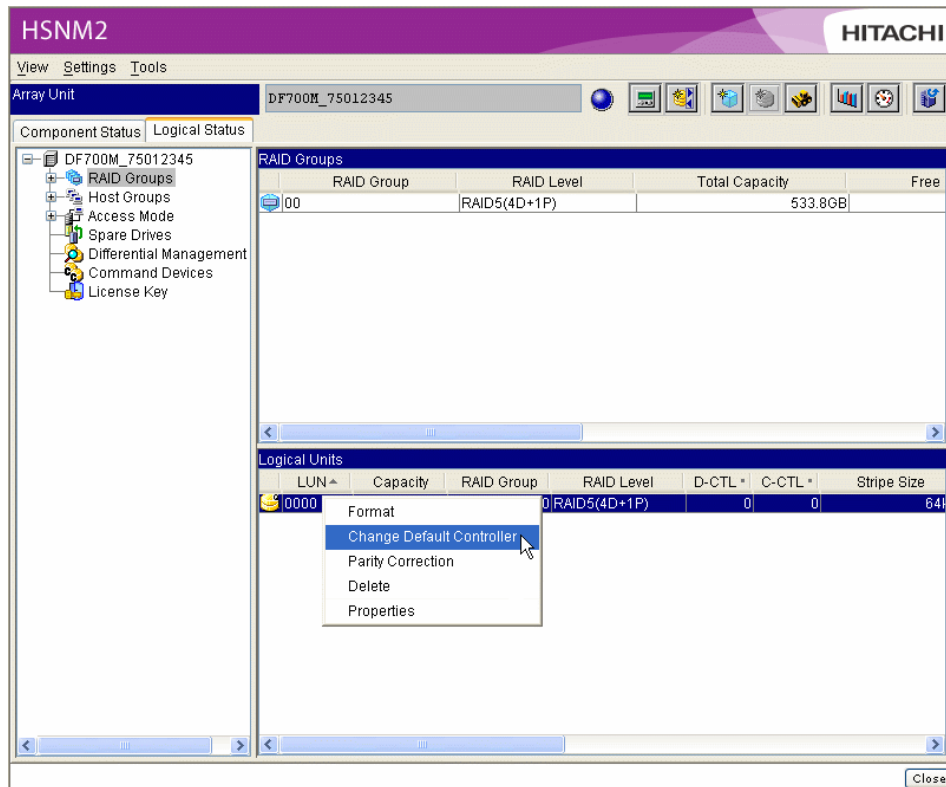

3. To continue through confirmation and status messages, click **OK**.
The default controller in charge of the logical unit is changed.



Note: Switching the default controller owning the logical unit changes the default controller currently displayed. When the switching is executed twice, the specified controller is changed to the original default controller that is controlling the logical unit.

Parity Correction

Restore the logical unit in which the parity error occurred. From the status of the logical unit, you can determine if a parity error has occurred.

1. Click the **Logical Status** tab on the **Array Unit** screen.
2. Select the logical unit to which you want to correct parity. Select **Logical Unit** in the **Settings** menu, and then select **Parity Correction**. See following figure.

If the parity restoration displays in halftone, no parity error has occurred.

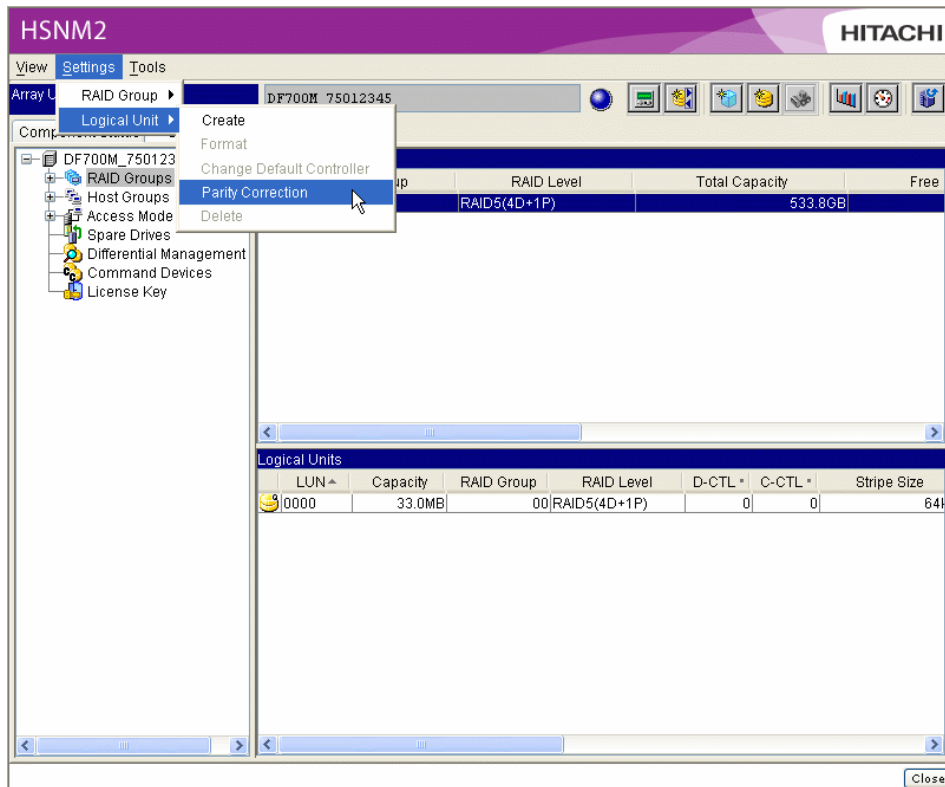

To continue, click **OK** in the confirmation message.

The unconnected logical units list displays. See following figure.

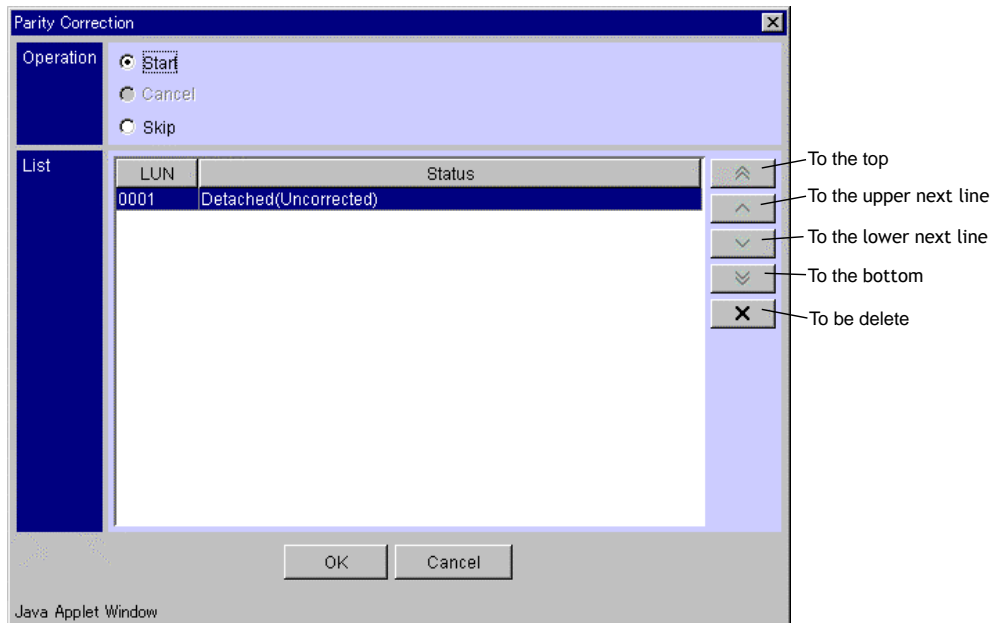

3. Change the order of the restoration process, when necessary.
(The logical unit listed at the top is processed first.)

4. To continue, click **Start**, and then click **OK**. (Or to cancel, click **Skip** and click **OK**.)
5. A message displays. Click **OK**.
6. A message displays stating that the parity correction has started. Click **OK**.
The Navigator 2 only directs the process being performed. The array unit firmware performs the specific operation.

Configuring Array Unit

Creating Logical Units by Wizard

To create logical units by wizard:

1. On the **Tools** menu, select **Wizard → Create Logical Units**.

On the **Select Usage** drop down list (see following figure), select logical unit usage. A dialog box displays where you can select the usage by setting the suitable parameter for **Drive Type**, **RAID Level**, and **Parity**. If you want to customize the parameter, click **Customize** and select Parameter to set the **Drive Type**, **RAID Level**, and **Parity**. See Table 5.1.

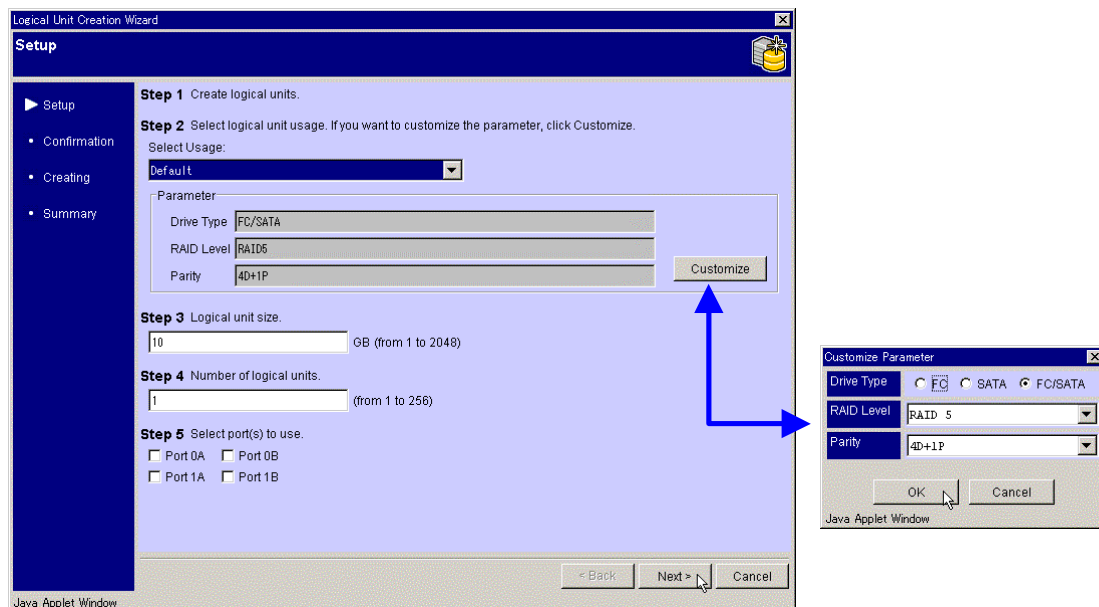
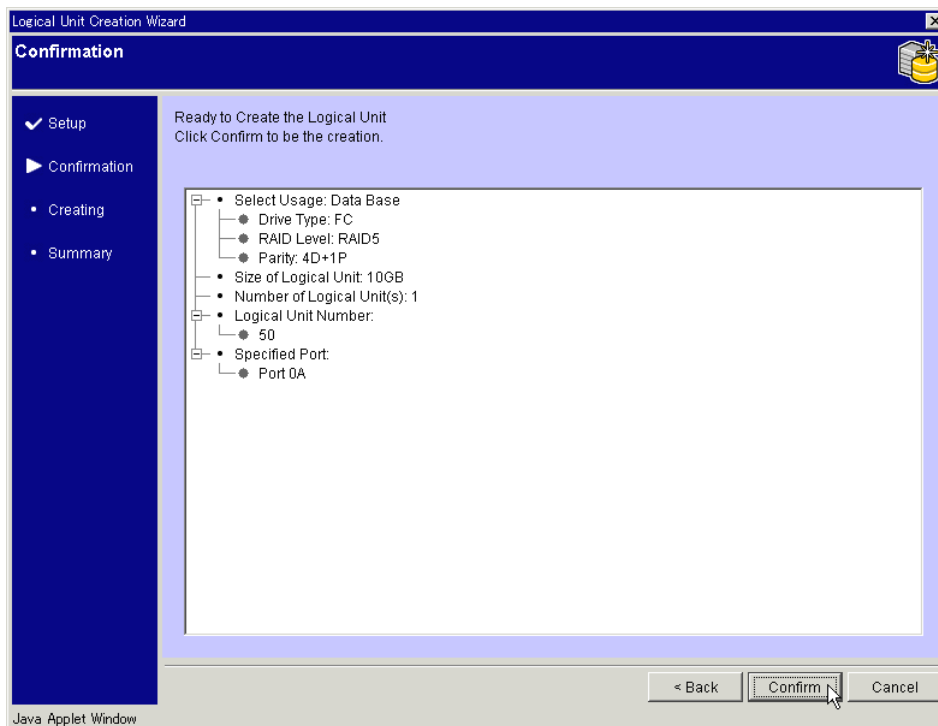

Table 5.1 Usage for Logical Unit

Usage	Recommended RAID configuration	Drive type
Default	4D+1P	FC/SATA
Data Base	4D+1P	FC
File System	4D+1P	FC
Backup	8D+1P	FC
Archive	8D+1P	SATA
Archive2	8D+2P	SATA
Streaming	4D+1P	SATA
Digital Surveillance System	8D+1P	FC
High Performance Computing	4D+4D	FC

- Specify the logical unit size, number of logical units, and port(s) to use.
- Select **Next**.
- The specification contents display. When the specification contents are no problem, click **Confirm**. If you want to modify the contents, click **Back**.



- Click **Done**. The Logical Unit Creation Wizard Summary displays.

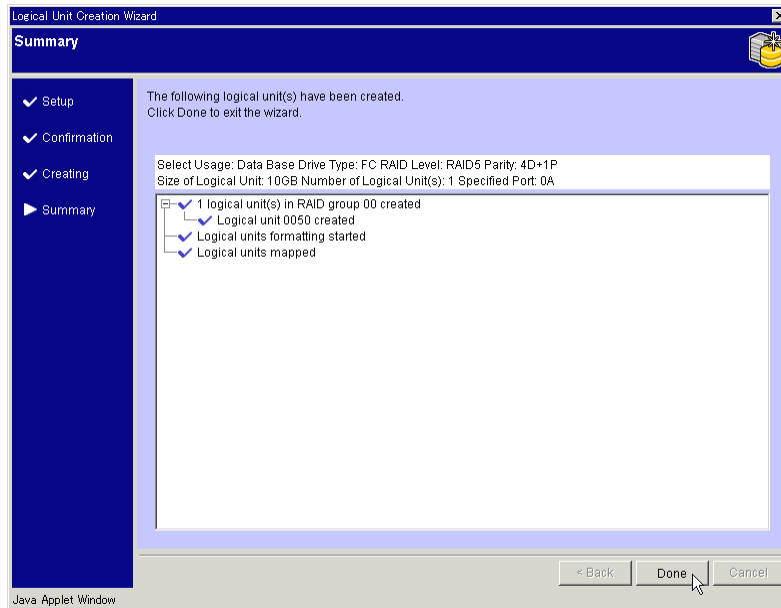

Designating Spare Drives

To ensure maximum storage capacity, assign a spare drive in the subsystem. Any drive except a data drive can be assigned as spare.

Designating Spare Drives

To designate a spare drive:

1. Click the **Logical Status** tab on the **Array Unit** screen.
2. Click the **Spare Drives** icon.

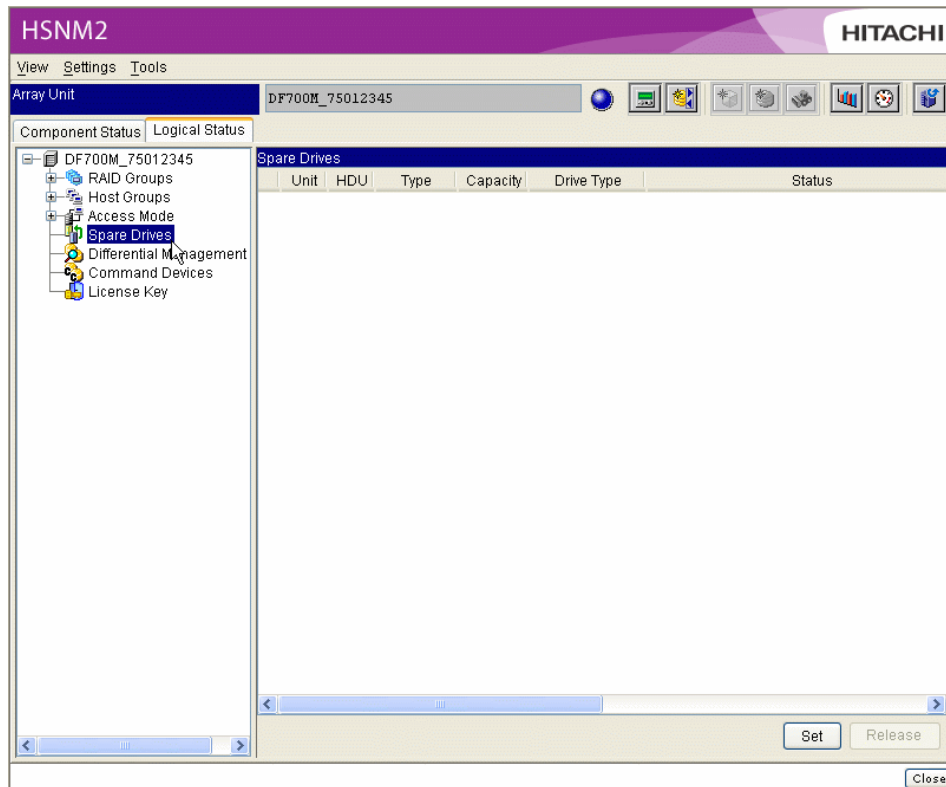

3. Click **Set**. The **Spare Drives Settings** dialog displays.

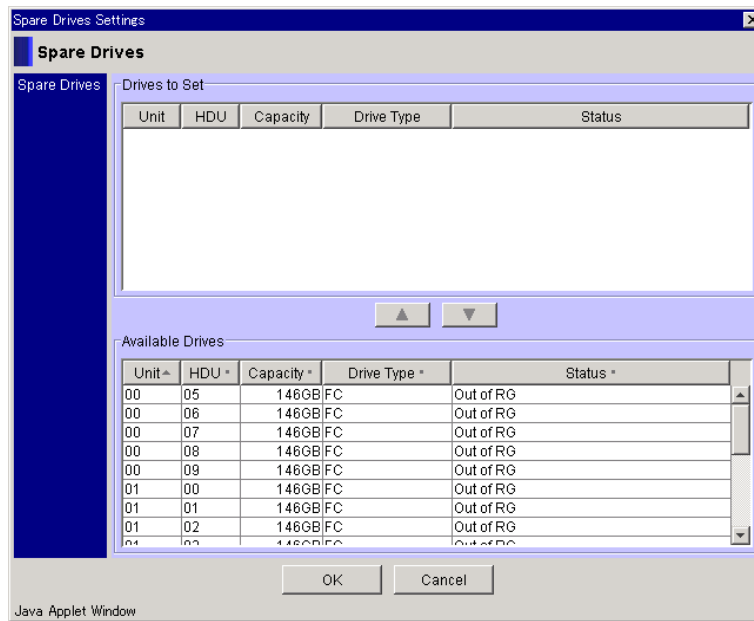

4. In the **Available Drives** list, select the **HDU** number for the spare drives you want to set, and click .

The selected **HDU** number moves to the **Drives to Set** list.

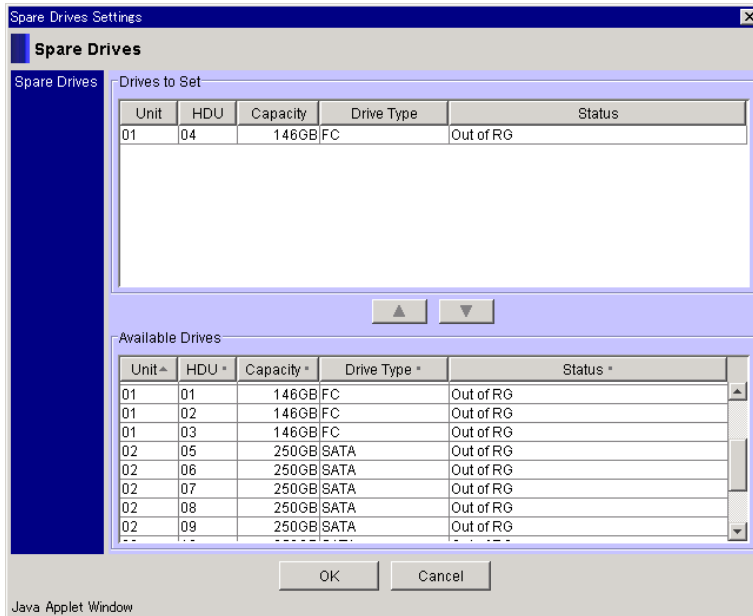

5. Click **OK**.
6. Confirmation and status messages display to continue through the confirmation and status messages, click **OK** and **Close**.

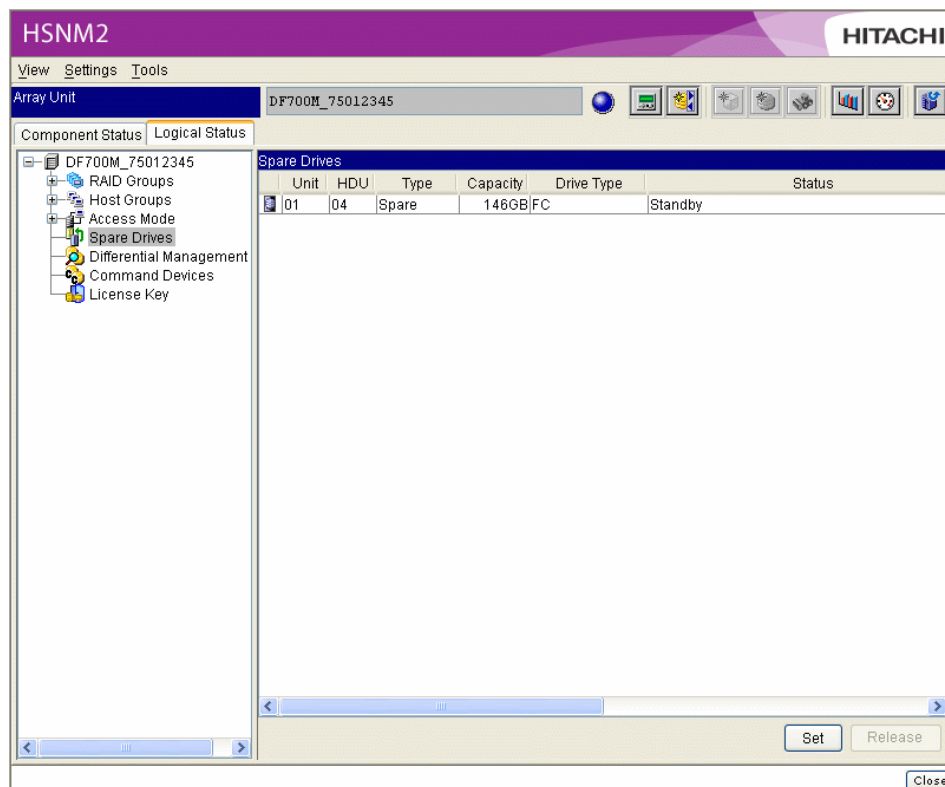

Releasing Spare Drive

To release the spare drive:

1. Click the **Logical Status** tab on the **Array Unit** screen.
2. Click the **Spare Drives** icon.

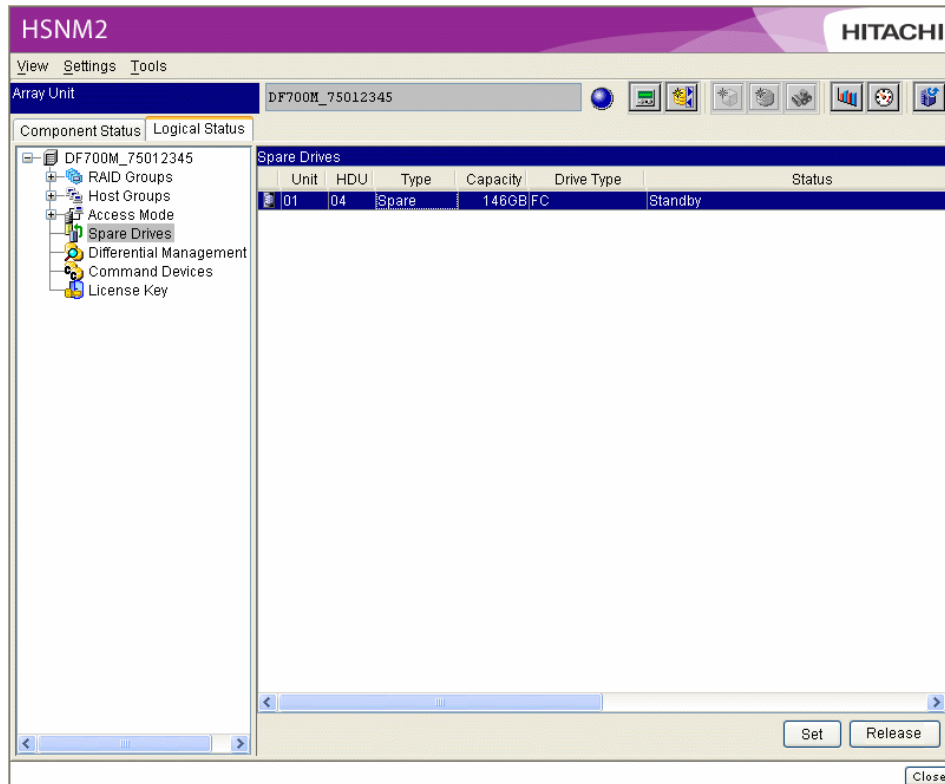

3. Select the HDU number of the spare drives you want to release. Click **Release**. Confirmation and status messages display. To continue through the confirmation and status messages, click **OK** and **Close**. The setting information displays.

Setting Differential Management LU

When the Differential Management LU is not set, you can set it. The Differential Management LU is an exclusive logical unit for storing the differential data at the time when the volume is copied. The Differential Management LU in the disk subsystem is treated in the same way as the other logical units. However, a logical unit that is set as the Differential Management LU is not recognized by a host because it is hidden.

The minimum logical unit size for the Differential Management LU is 5 GB. Up to the two Differential Management LUs can be set. The second Differential Management LU is used for the mirroring.

Setting Differential Management LU

To set the Differential Management LU:

1. Click the **Logical Status** tab on the **Array Unit** screen.
2. Click the **Differential Management LU** icon.

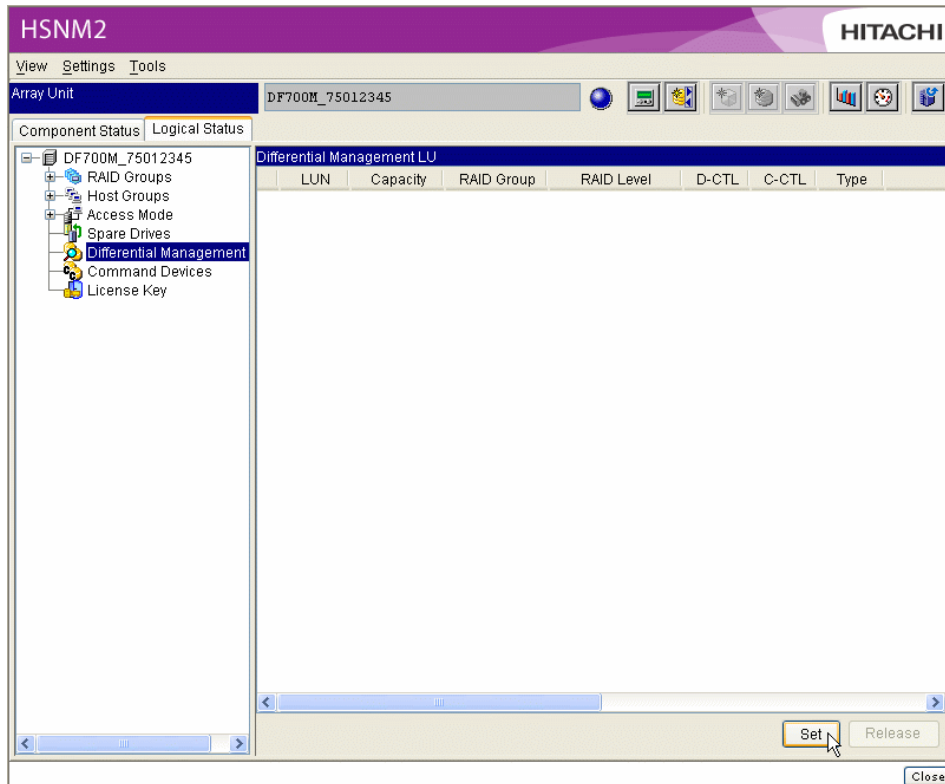

3. Click **Set**.

The **Select Logical Unit** dialog box displays.

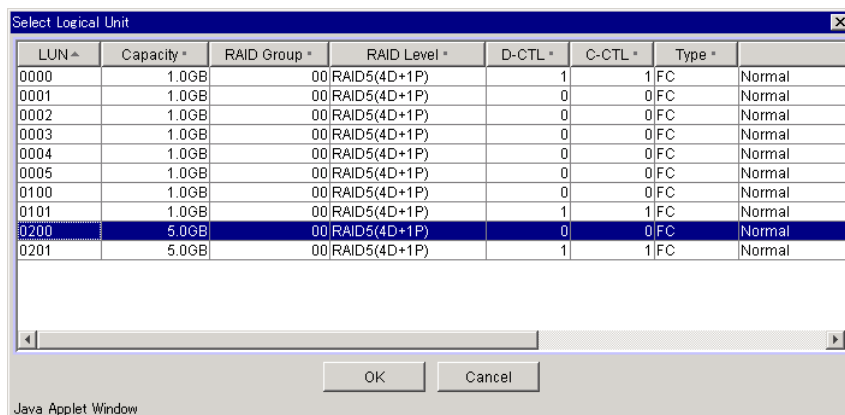

4. Select the LUN you want to set to the differential management LU, and click **OK**.

5. Confirmation and status messages display. To continue through the confirmation and status messages, click **OK**.

The setting information displays.

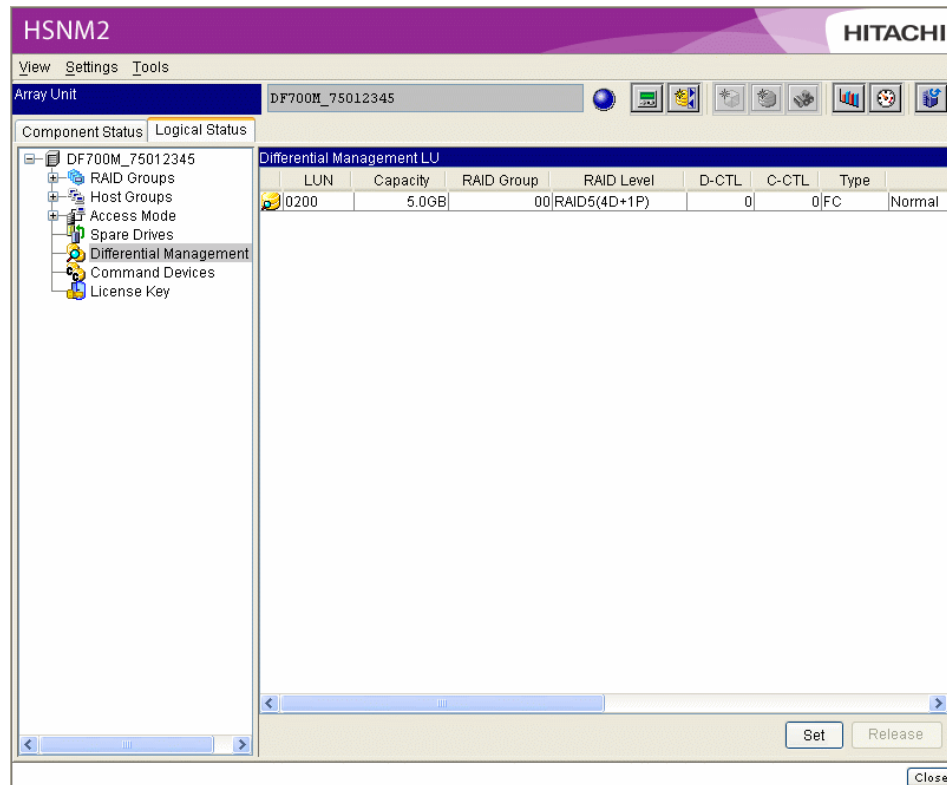

Releasing Differential Management LU

To release the differential management LU:

1. Click the **Logical Status** tab on the **Array Unit** screen.
2. Click the **Differential Management LU** icon.

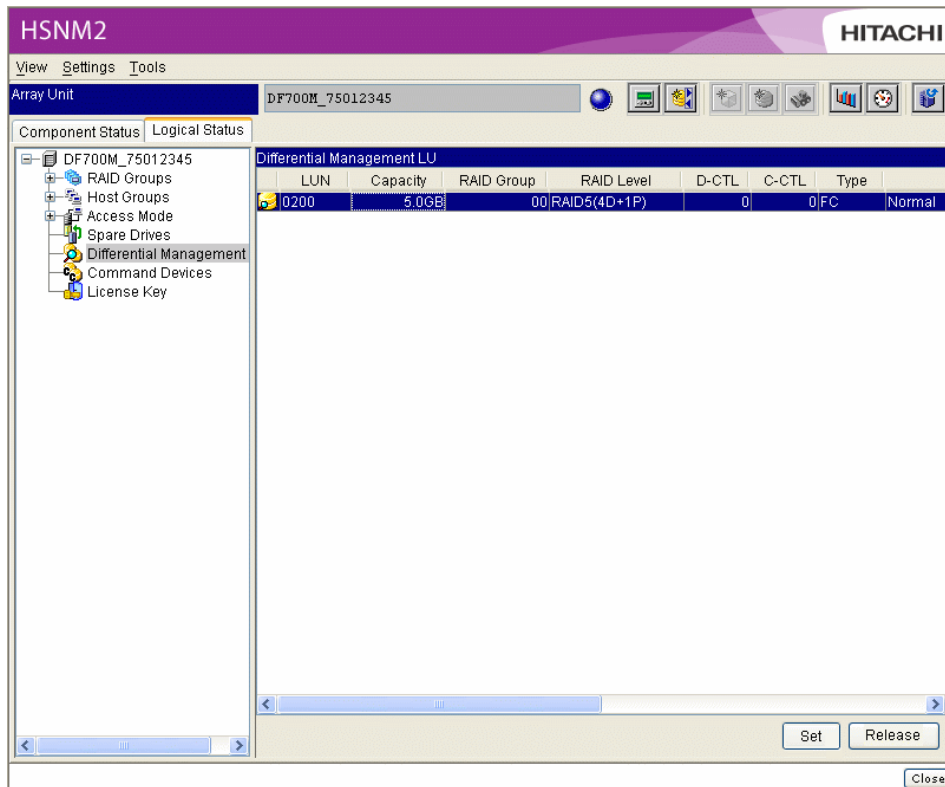

3. Select the LUN you want to release to the differential management LU, and click **Release**.
 4. Confirmation and status messages display. To continue through the confirmation and status messages, click **OK**.
- The setting information displays.

Setting Command Devices

Two command devices can be designated for the subsystem. The Command Device LU size must be greater than or equal to 33 MB.

Setting Command Devices

1. Click the **Logical Status** tab on the **Array Unit** screen.
2. Click the **Command Devices** icon.

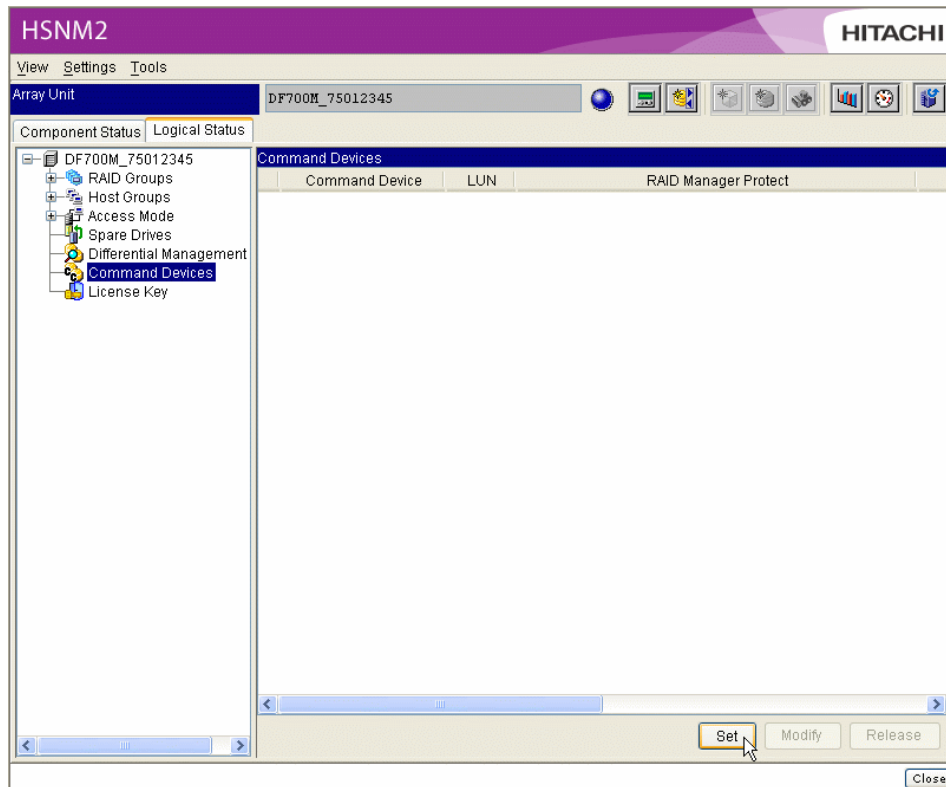

3. Click **Set**.

The **Command Devices Settings** dialog box displays.

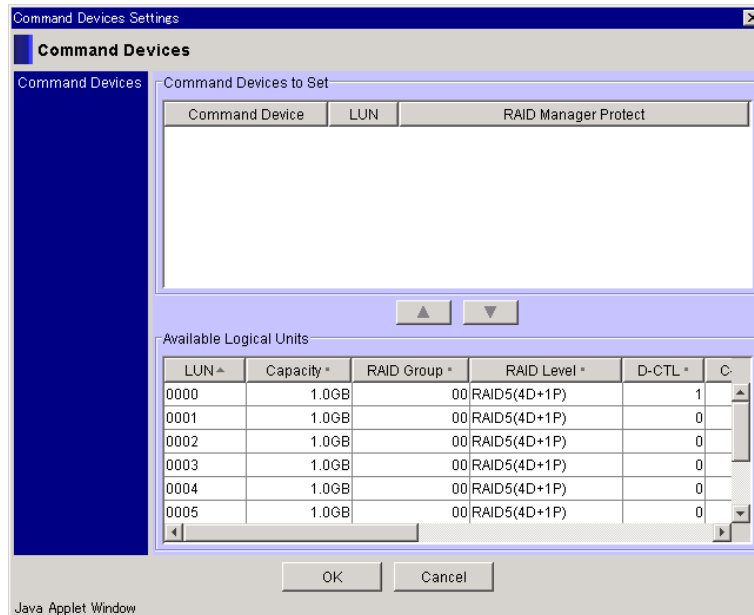

4. In the **Available Logical Units** list, select the LUN you want to set in the command devices, and click **▲**.

The selected LUN moves to the **Command Devices to Set** list.

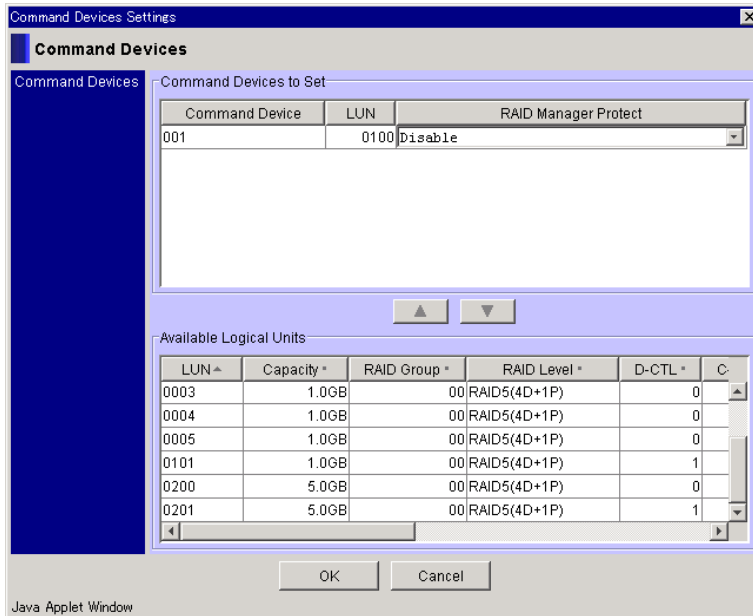

5. Click **OK**.
6. A message displays. Click **OK**.
The setting information displays.

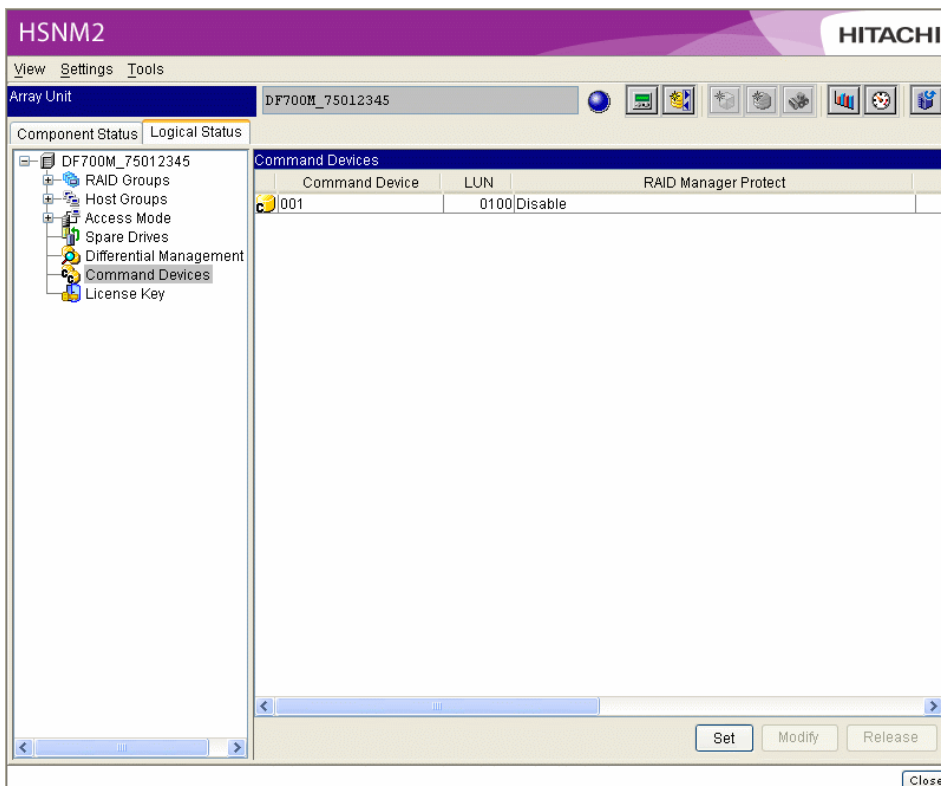

Changing Command Devices

To change the command devices:

1. Click the **Logical Status** tab on the **Array Unit** screen.
2. Click the **Command Devices** icon.

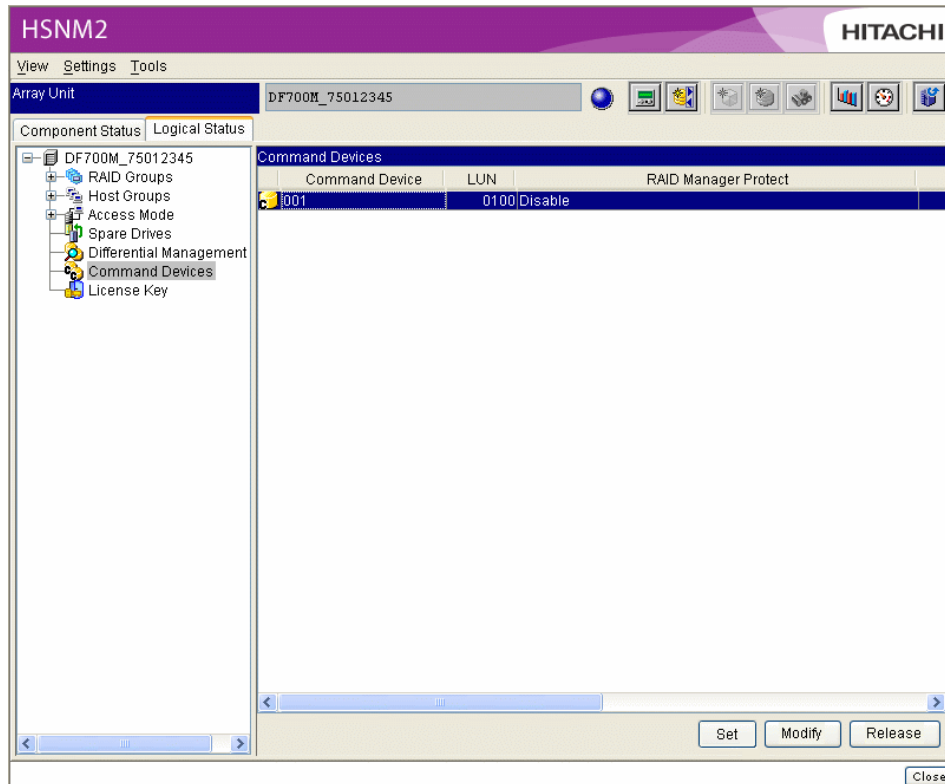

3. Select the **Command Device** number you want to change in the Command Device list, and click **Modify**.

The **Modify Command Devices** dialog box displays.

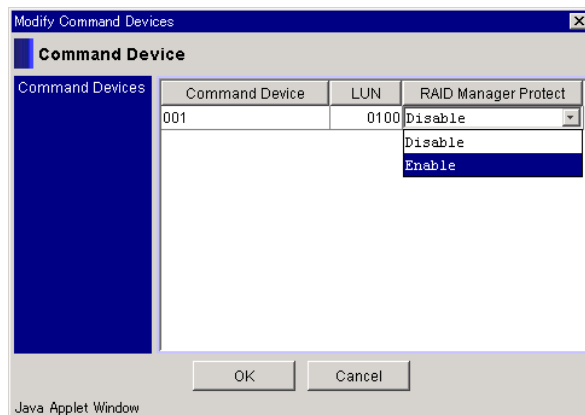

4. In the **RAID Manager Protect** drop-down list, select **Disable** or **Enable**.

5. Click **OK**.
6. Confirmation and status messages display. Click **OK** to continue through confirmation and status messages.

The setting information displays.

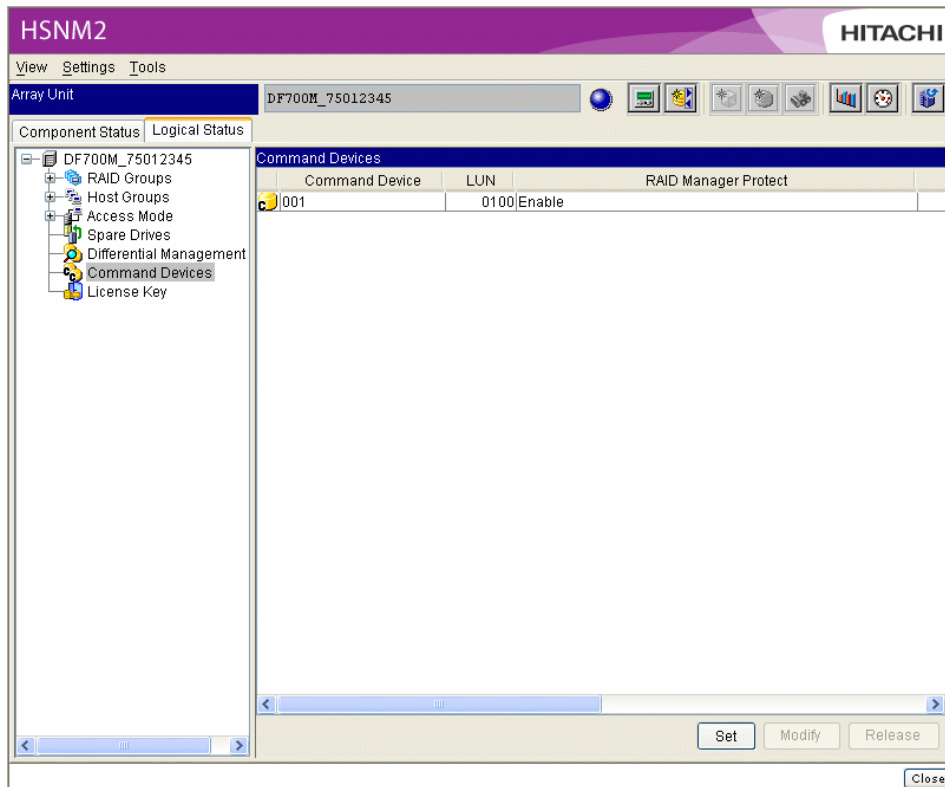

Releasing Command Devices

To release the command devices:

1. Click the **Logical Status** tab on the **Array Unit** screen.
2. Click the **Command Devices** icon.
3. Select the **Command Device** number you want to release the command devices, and click **Release**.
4. Confirmation and status messages display. Click **OK** to continue through confirmation and status messages.

The setting information displays.

Setting Optional Features

This section describes how to install and uninstall optional features.

Installing Optional Features

WARNING: Rebooting requires stopping I/O from the host.

WARNING: If you are using TrueCopy or TrueCopy Extended Distance and you are required to reboot the subsystem, change the pair status to PSUS before you reboot.

WARNING: If you are using a NAS, you must also stop the clusters between NAS units. When restarting the subsystem, you must restart the clusters.

To install the optional features:

1. Click the **Logical Status** tab on the Array **Unit** screen.
2. Click the **License Key** icon.

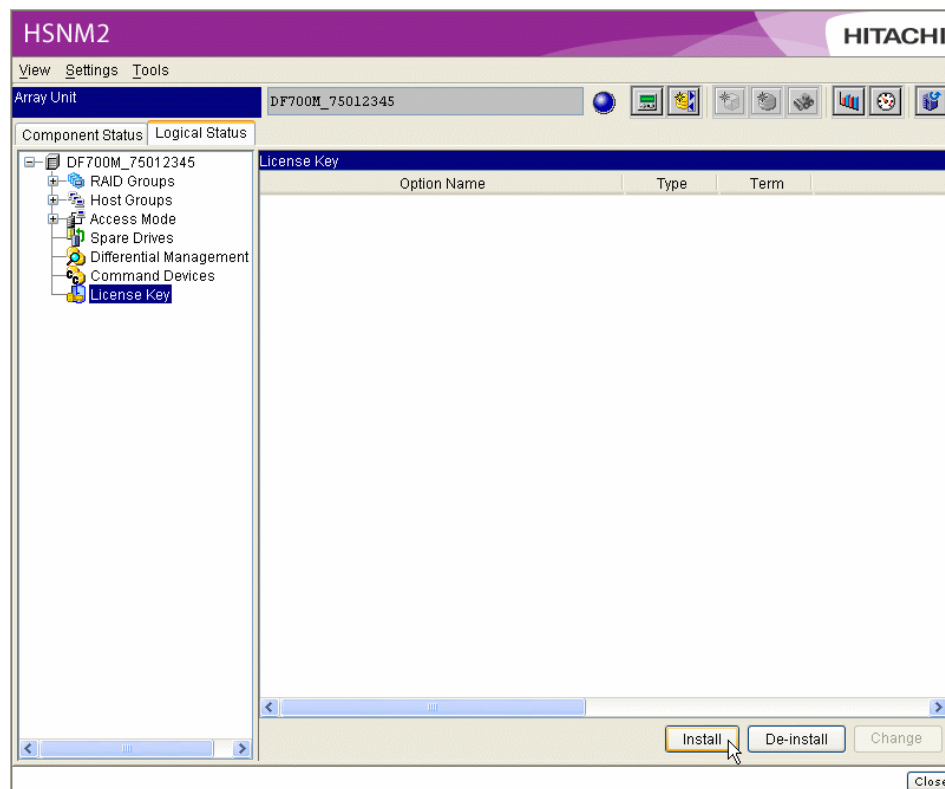

3. Click **Install**.

The **Install Options** dialog box displays.

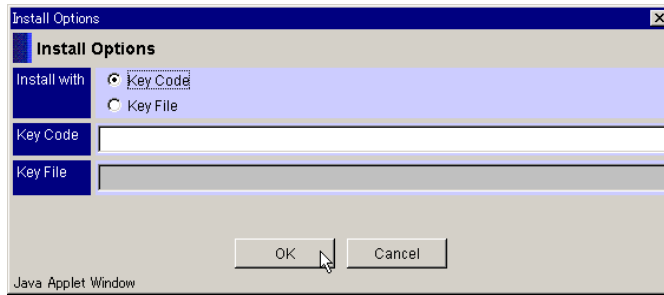

4. Choose an install option, **Key Code**, or **Key File**:

Key Code: For the key code of the priced optional features, refer to the priced optional features manual. In the Key Code field, enter the key code, and click **OK**.

Key File: In the Key File field, enter the path to the key file and click **OK**. An Install Options box displays. Select the desired features, and click **OK**.

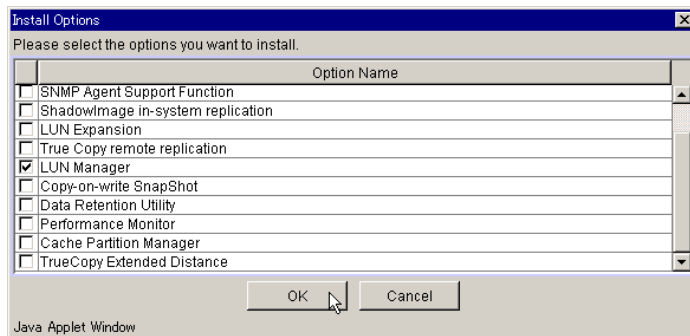

5. In any confirmation screens that display, click **OK** or **Close** to continue.
6. A status message indicates whether the install is successful.



Note: Some options may require a subsystem restart before the options are functional. Follow the on-screen instructions. Before restarting, ensure that the host is not accessing data on the subsystem. A subsystem restart takes about 4 to 15 minutes.

To perform other operations on the **Arrays** screen, select an Array Unit from the **Arrays** screen and open the selected **Array Unit** screen.



Note: For additional information on priced optional features, refer to the corresponding manual of each feature.

De-installing Optional Features

WARNING: Rebooting requires stopping I/O from the host.

WARNING: If you are using TrueCopy or TrueCopy Extended Distance and you are required to reboot the subsystem, change the pair status to PSUS before you reboot.

WARNING: If you are using a NAS, you must also stop the clusters between NAS units. When restarting the subsystem, you must restart the clusters.

To de-install the optional features:

1. Click the **Logical Status** tab on the **Array Unit** screen.
2. Click the **License Key** icon.
3. Click **De-install**.

The **De-install Options** dialog displays.

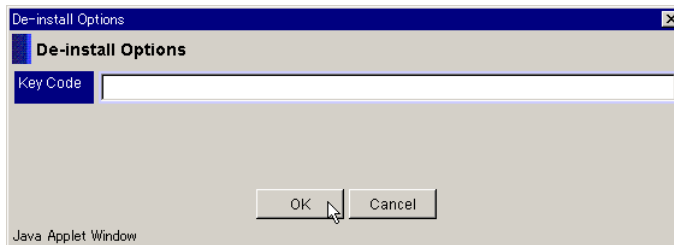

4. Enter the key code, and click **OK**.
5. A status message displays and indicates whether the de-install is successful.

Note: If the message indicates that a subsystem restart is needed, follow the instructions in the message. Before restarting, ensure that the host is not accessing data on the subsystem. A subsystem restart takes about 4 to 15 minutes.

To perform other operations on the **Arrays** screen, select an Array Unit from the **Arrays** screen and open the selected **Array Unit** screen.

Setting Optional Features

After releasing the key of the optional feature, set enable or disable this feature.

WARNING: Rebooting requires stopping I/O from the host.

WARNING: If you are using TrueCopy or TrueCopy Extended Distance and you are required to reboot the subsystem, change the pair status to PSUS before you reboot.

WARNING: If you are using a NAS, you must also stop the clusters between NAS units. When restarting the subsystem, you must restart the clusters.

To set the optional features:

1. Click the **Logical Status** tab on the Array Unit screen.
2. Click the **License Key** icon.

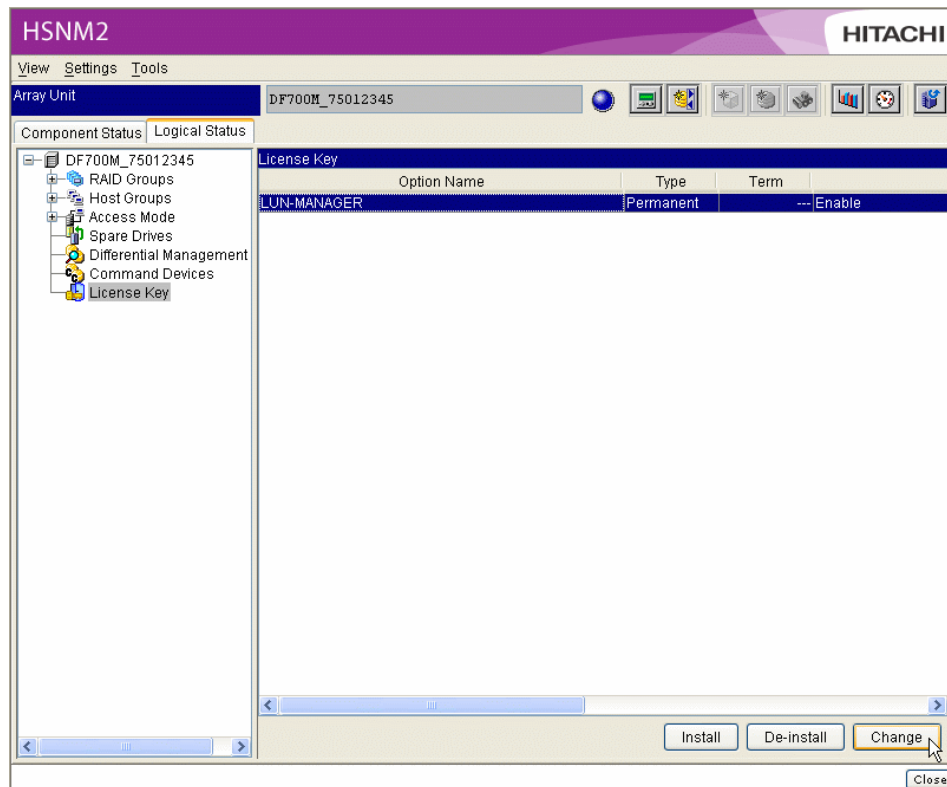

3. Select the optional features to be set up, and click **Change**.
4. A confirmation message displays. Click **OK** to continue setting the enable/disable option.
5. A status message displays and indicates that the priced optional features have been set up.



Note: If the message indicates that a subsystem restart is needed, follow the instructions in the message. Before restarting, ensure that the host is not accessing data on the subsystem. A subsystem restart takes about 4 to 15 minutes.

To perform other operations on the **Arrays** screen, select an Array Unit from the **Arrays** screen and open the selected **Array Unit** screen.

Setting Host Group Information

This section contains information about setting a host group 0 (000:G000), such as a host group option and mapping information.

For information on creating a host group, refer to the LUN Manager User's Guide.

Setting Host Group Options

To set the host group options:

1. Click the **Logical Status** tab.
2. Click the **Port 0A** plus sign.
3. Click the **000:G000** plus sign, then select **Options**.
4. Click **Simple Settings**.

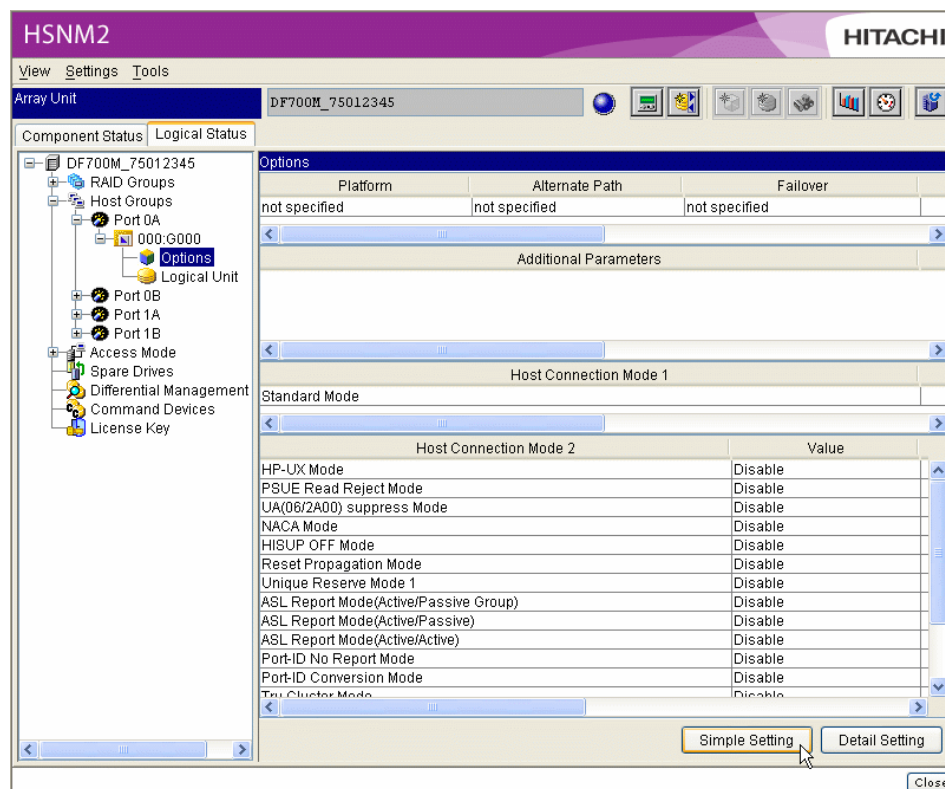

5. As necessary, select **Platform**, **Alternate Path**, and **Failover**. See following figure. The combination, which can be chosen for every platform, is limited.

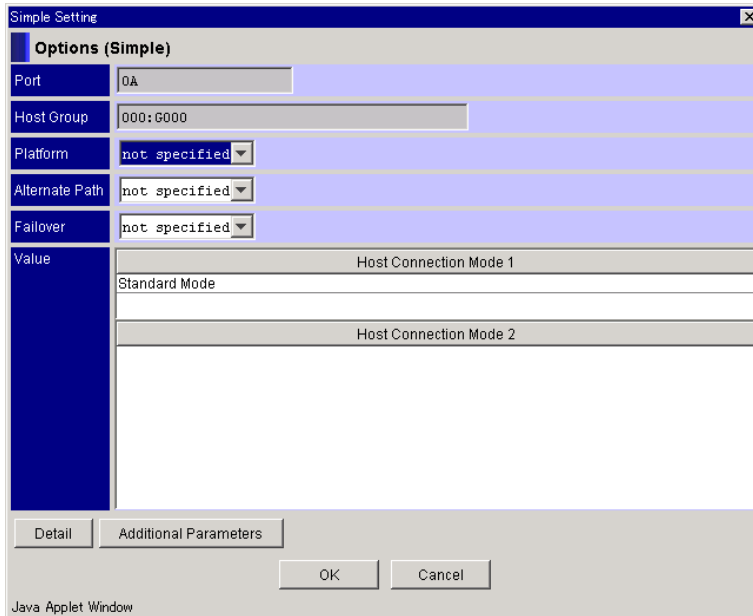

Platform:

- HP-UX
- Solaris
- AIX®
- Windows 2000
- Windows 2003
- Linux®
- Tru64
- not specified

Alternate path:

- not specified
- PV Link: Can be used by HP-UX.
- HDLM: Can be used by Solaris, AIX, and Windows 2000/2003.
- VxVM: Can be used by HP-UX, AIX, Solaris, Windows 2000/2003, and Linux.
- MPxIO: Can be used by Solaris.

Failover:

- not specified
- MC/ServiceGuard: Can be used by HP-UX.
- SunCluster: Can be used by Solaris.
- VCS: Can be used by Solaris and Linux.
- HACMP: Can be used by AIX.
- MSCS: Can be used by Windows 2000/2003.

- Tru Cluster: Can be used by Tru64.

6. Click **Additional Parameters**.

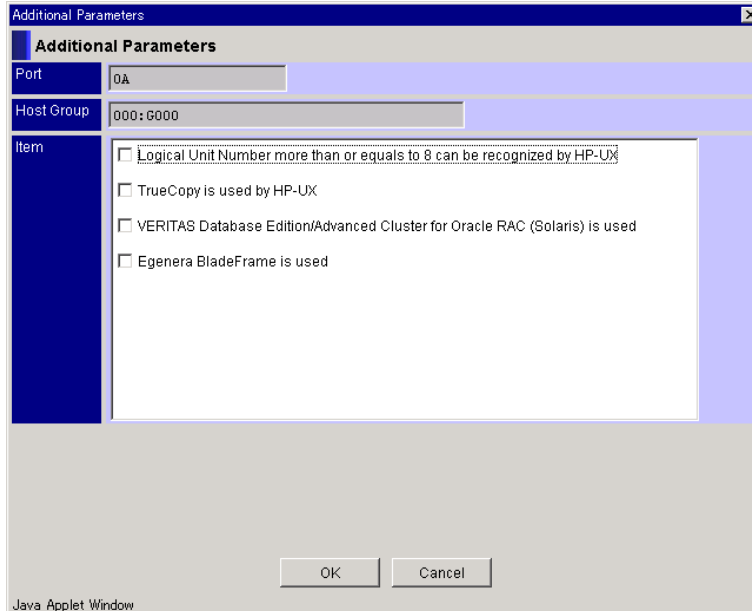

7. Select the appropriate options in the **Item** group and click **OK**.

8. Click **Detail**.

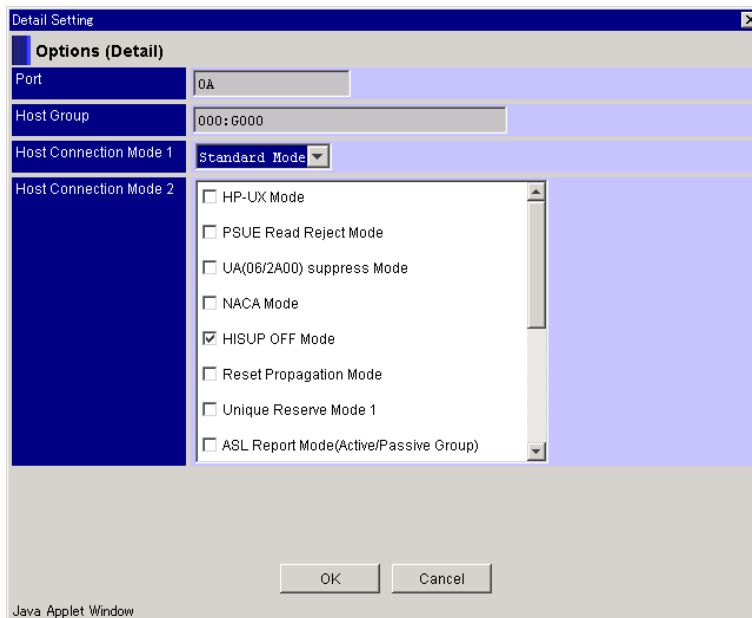

9. Select **Host Connection Mode 1**, **Host Connection Mode 2** and click **OK**.

Host Connection Mode 1:

- Standard Mode: Open system emulation mode
- Open VMS Mode: Open VMS mode
- TRESPASS Mode: TRESPASS mode

- Wolfpack Mode: Wolfpack mode

Host Connection Mode 2:

- HP-UX Mode: Enables the HP-UX Mode.
- PSUE Read Reject Mode: Enables the PSUE Reject Mode.
- UA (60/2A00) Suppress Mode: Suppresses the unit attention (06/2A00).
- NACA Mode: Enables the NACA Mode.
- HISUP OFF Mode: Enables the HISUP OFF Mode.
- Reset Propagation Mode: The mode to propagate reset to other ports.
- Unique Reserve Mode 1: Enables the Unique Reserve Mode 1.
- ASL Report Mode (Active/Passive Group): Enables the ASL Report Mode (Active/Passive Group).
- ASL Report Mode (Active/Passive): Enables the ASL Report Mode (Active/Passive).
- ASL Report Mode (Active/Active): Enables the ASL Report Mode (Active/Active).
- Port ID No Report Mode: Enables the Port ID No Report Mode.
- Port ID Conversion Mode: Enables the Port ID Conversion Mode.
- Tru Cluster Mode: Enables the Tru Cluster Mode.
- Product Serial Response Mode: Enables the Product Serial Response Mode.
- Same Node Name Mode: Enables the Same Node Name Mode.
- CCHS Mode: Enables the CCHS convert.
- SPC-2 Mode: Enables the SPC-2 Mode.

10. Click **OK**.

11. A confirmation message displays. Click **OK**.

The modified host group options display.

Setting Mapping Guard

Mapping guard is a function to protect mapping setting against erroneous operation. Users cannot perform the mapping operation on the Navigator 2 to the logical unit on which the mapping guard is set to effective.

To enable or disable Mapping Guard:

1. Click the **Logical Status** tab on the Array Unit screen.
2. On the **Tools** menu, select **Mapping Guard**.

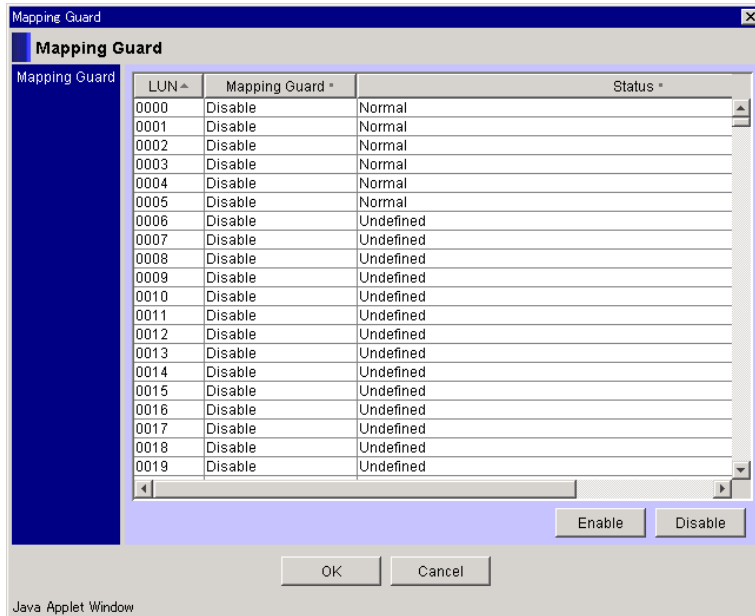

3. In the **Mapping Guard** window.
 - a) Select a **LUN**.
 - b) Click **Enable** or **Disable**.
 - c) Click **OK**.
4. A confirmation message displays. Click **OK**.

Specifying Mapping Mode

To enable or disable Mapping Mode:

1. Click the **Logical Status** tab on the Array Unit screen.
2. Click the **Access Mode** plus sign next to the **Mapping Mode**.

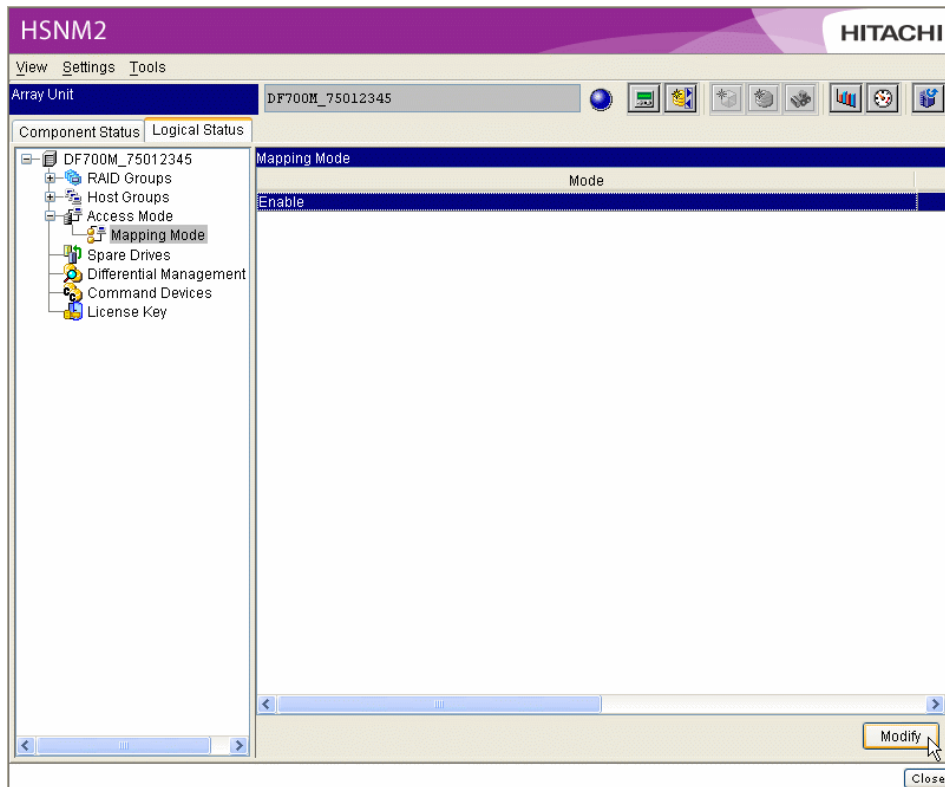

3. On the **Mapping Mode** list, select **Enable or Disable** and click **Modify**.
This operation can also be done from the context menu of the list view.
The **Modify Mapping Mode** dialog box displays.

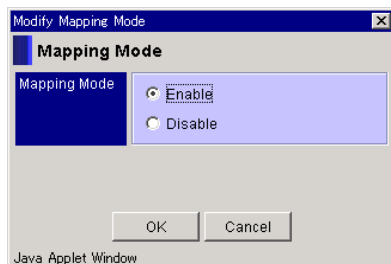

4. Select **Enable or Disable** and click **OK**.
5. A confirmation message displays. Click **OK**.
The setting information displays.

Setting Mapping Information

To set mapping information:

1. Click the **Logical Status** tab on the Array Unit screen.
2. Click the **Port 0A** plus sign and select **000:G000**.
3. Select the **Logical Unit** icon.

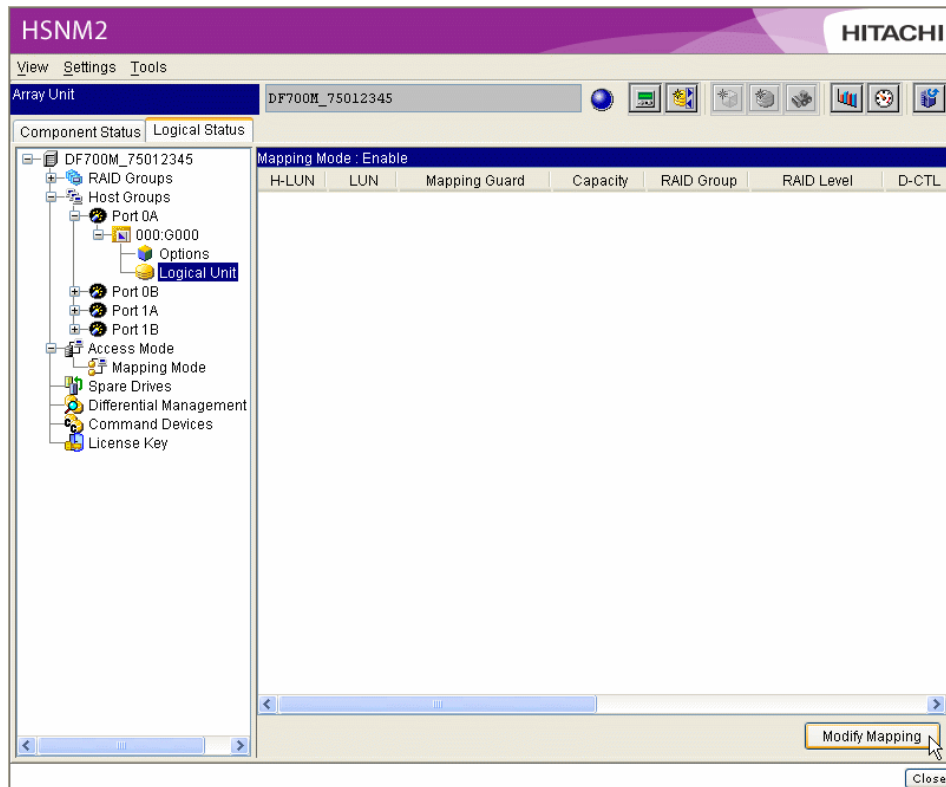

4. Select **Modify Mapping**.

The **Modify Mapping** dialog box displays.

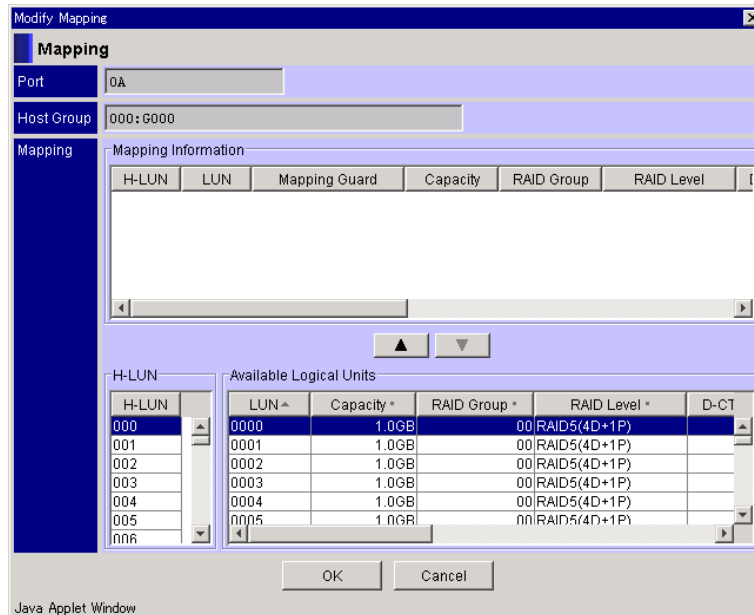

5. Select one **H-LUN** to be added. Select **LUN**, and click . The added contents display in the **Mapping Information** list.

To delete, click the line to be deleted in **Mapping Information** list and click . The deleted contents disappear.

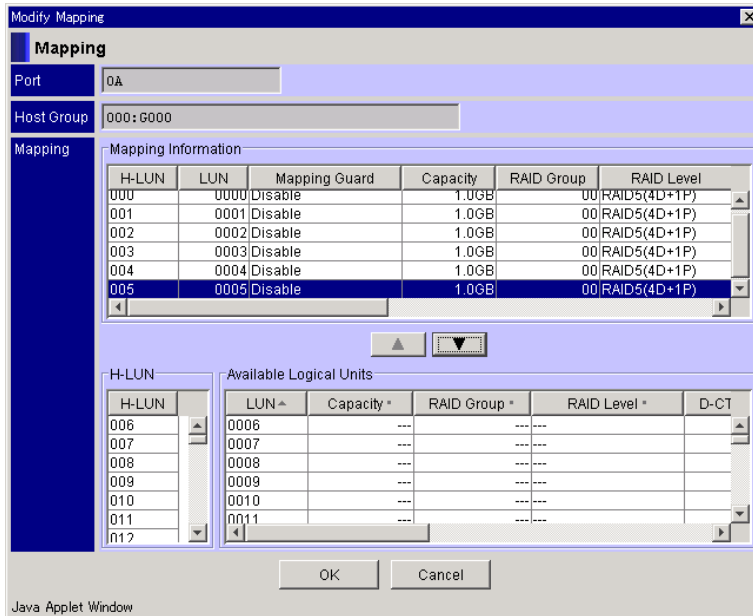

6. Click **OK**.

7. A confirmation message displays. Click **OK**.

The set mapping information is updated and the following window displays.

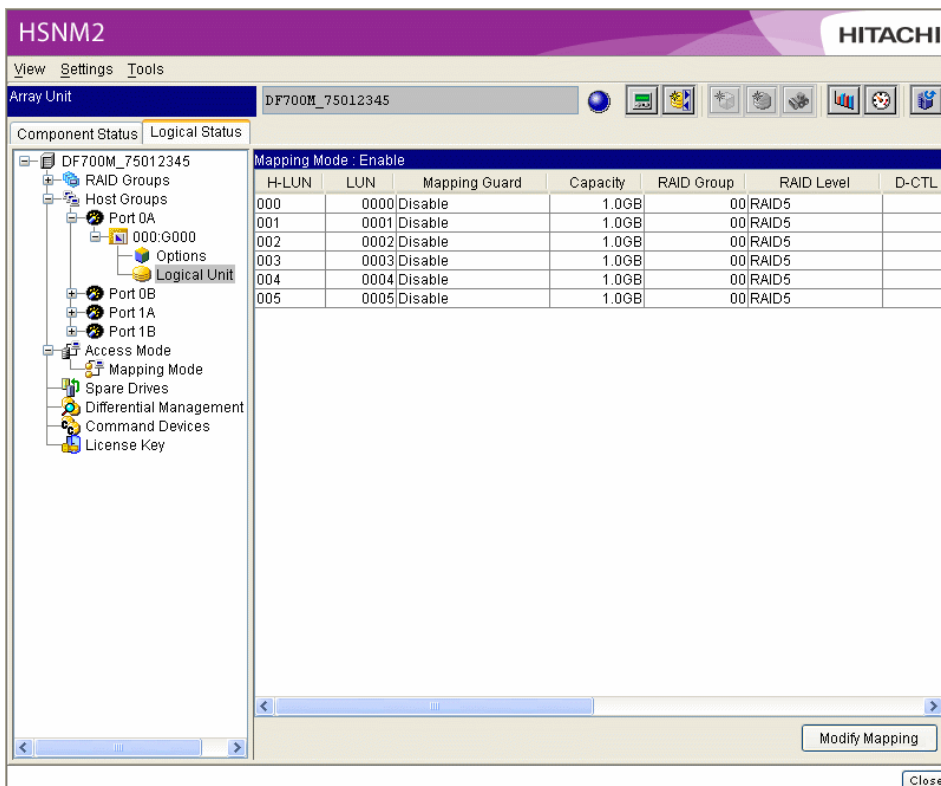

Setting Target Information

This section contains information about setting Target 0 (000:T000) information, such as a target options and mapping information. For information on creating a target, refer to the LUN Manager User's Guide.

Setting Target Options

To set the target options:

1. Click the **Logical Status** tab.
2. Click the **Port 0A** plus sign.
3. Click the **000:T000** plus sign and select **Options**.
4. Click **Simple Settings**.

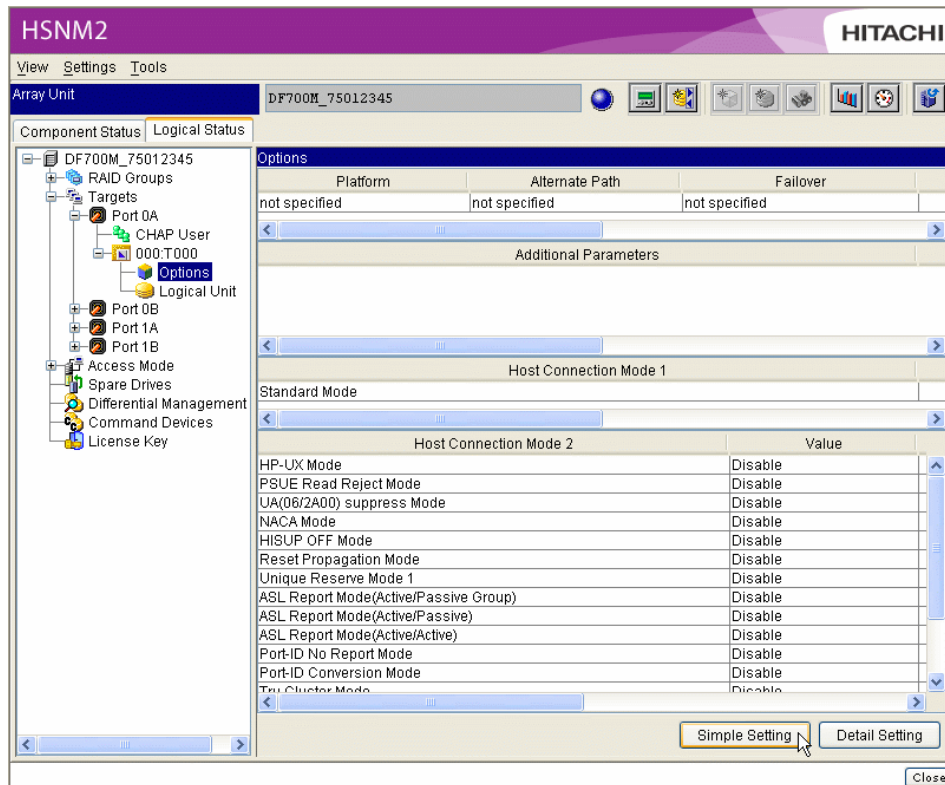

5. As necessary, select **Platform**, **Alternate Path**, and **Failover**. The combination, which can be chosen for every platform, is limited.

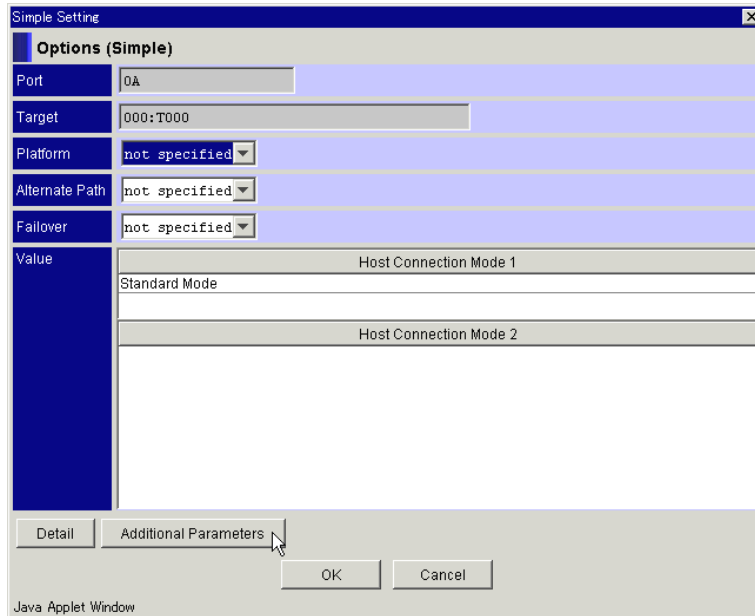

Platform:

- HP-UX
- Solaris
- AIX
- Windows 2000
- Windows 2003
- Linux
- Tru64
- not specified

Alternate path:

- not specified
- PV Link: Can be used by HP-UX.
- HDLM: Can be used by Solaris, AIX®, and Windows 2000/2003.
- VxVM: Can be used by HP-UX, AIX®, Solaris, Windows 2000/2003, and Linux.
- MPxIO: Can be used by Solaris.

Failover:

- not specified
- MC/ServiceGuard: Can be used by HP-UX.
- SunCluster: Can be used by Solaris.
- VCS: Can be used by Solaris and Linux.
- HACMP: Can be used by AIX.
- MSCS: Can be used by Windows 2000/2003.

- Tru Cluster: Can be used by Tru64.

6. Click **Additional Parameters**.

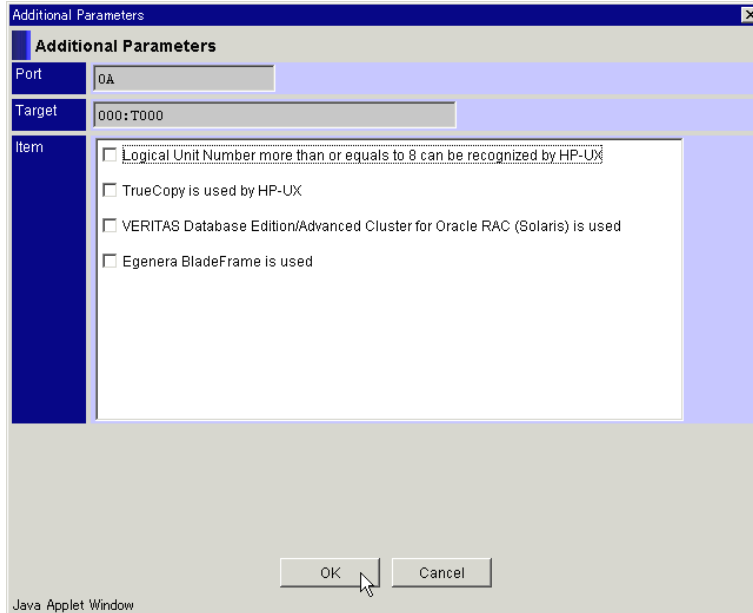

7. Select the appropriate options in the **Item** group and click **OK**.

8. Click **Detail**.

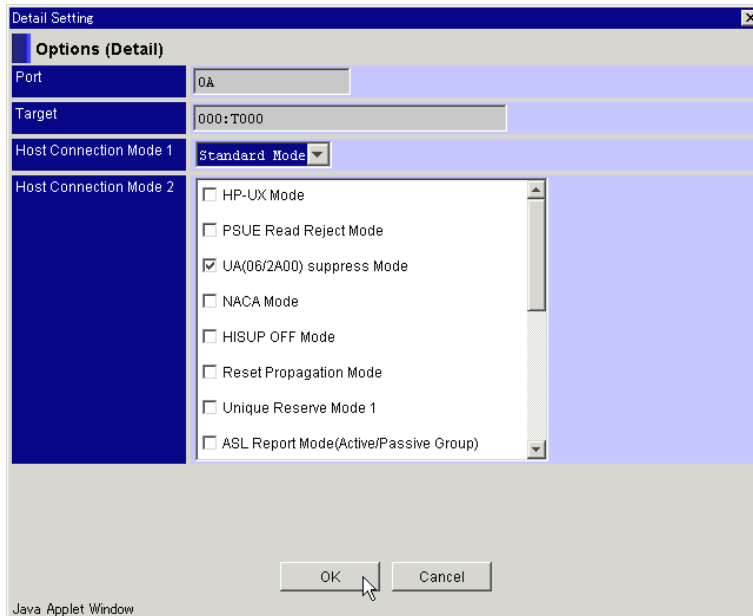

9. Select **Host Connection Mode 1**, **Host Connection Mode 2** and click **OK**.

Host Connection Mode 1:

- Standard Mode: Open system emulation mode
- Open VMS Mode: Open VMS mode
- TRESPASS Mode: TRESPASS mode

- Wolfpack Mode: Wolfpack mode

Host Connection Mode 2:

- HP-UX Mode: Enables the HP-UX Mode.
- PSUE Read Reject Mode: Enables the PSUE Reject Mode.
- UA (60/2A00) Suppress Mode: Suppresses the unit attention (06/2A00).
- NACA Mode: Enables the NACA Mode.
- HISUP OFF Mode: Enables the HISUP OFF Mode.
- Reset Propagation Mode: The mode to propagate reset to other ports.
- Unique Reserve Mode 1: Enables the Unique Reserve Mode 1.
- ASL Report Mode (Active/Passive Group): Enables the ASL Report Mode (Active/Passive Group).
- ASL Report Mode (Active/Passive): Enables the ASL Report Mode (Active/Passive).
- ASL Report Mode (Active/Active): Enables the ASL Report Mode (Active/Active).
- Port ID No Report Mode: Enables the Port ID No Report Mode.
- Port ID Conversion Mode: Enables the Port ID Conversion Mode.
- Tru Cluster Mode: Enables the Tru Cluster Mode.
- Product Serial Response Mode: Enables the Product Serial Response Mode.
- Same Node Name Mode: Enables the Same Node Name Mode.
- CCHS Mode: Enables the CCHS convert.
- SPC-2 Mode: Enables the SPC-2 Mode.

10. Click **OK**.

11. A confirmation message displays. Click **OK**.

The modified target options display.

Setting Mapping Guard

To enable or disable Mapping Guard:

1. Click the **Logical Status** tab on the Array Unit screen.
2. On the **Tools** menu, select **Mapping Guard**.

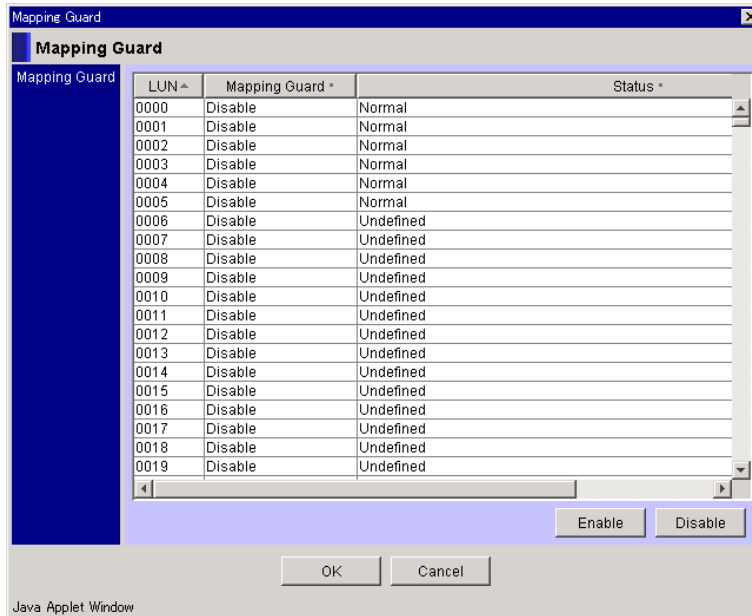

3. In the **Mapping Guard** window:
 - a) Select a **LUN**.
 - b) Click **Enable** or **Disable**.
 - c) Click **OK**.
4. A confirmation message displays. Click **OK**.

Specifying Mapping Mode

To enable or disable **Mapping Mode**:

1. Click the **Logical Status** tab on the Array Unit screen.
2. Click the **Access Mode** plus sign. Select **Mapping Mode**.

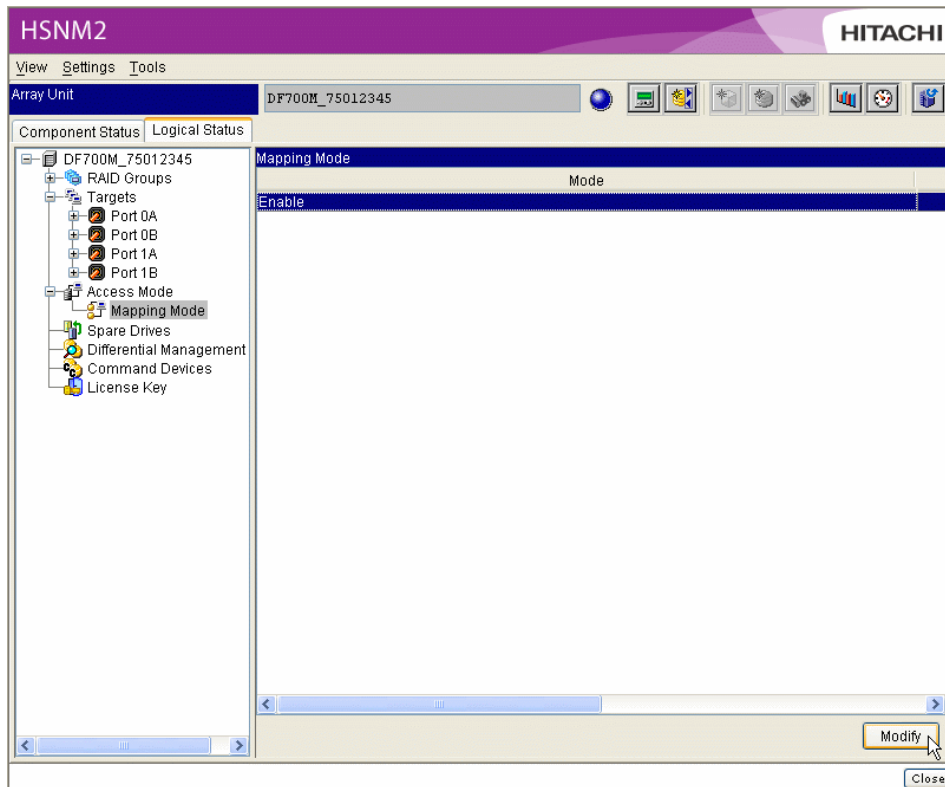

3. On the **Mapping Mode** list, select **Enable or Disable**, and click **Modify**.
This operation can also be done from the context menu of the list view.
The **Modify Mapping Mode** dialog box displays.

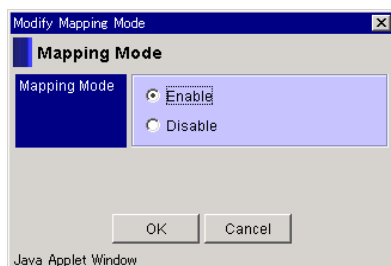

4. Select **Enable or Disable** and click **OK**.
5. A confirmation message displays. Click **OK**.
The setting information displays.

Setting Mapping Information

To set mapping information:

1. Click the **Logical Status** tab on the Array Unit screen.
2. Click the **Port 0A** plus and select **000:T000**.
3. Select the **Logical Unit** icon.

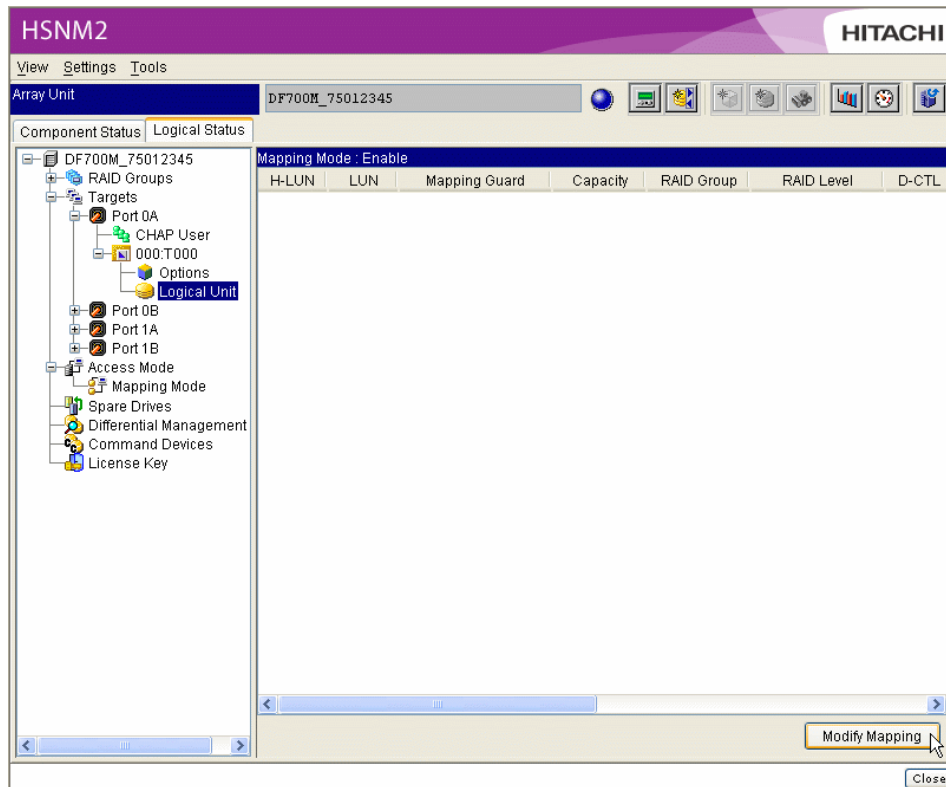

4. Select **Modify Mapping**.

The **Modify Mapping** dialog box displays.

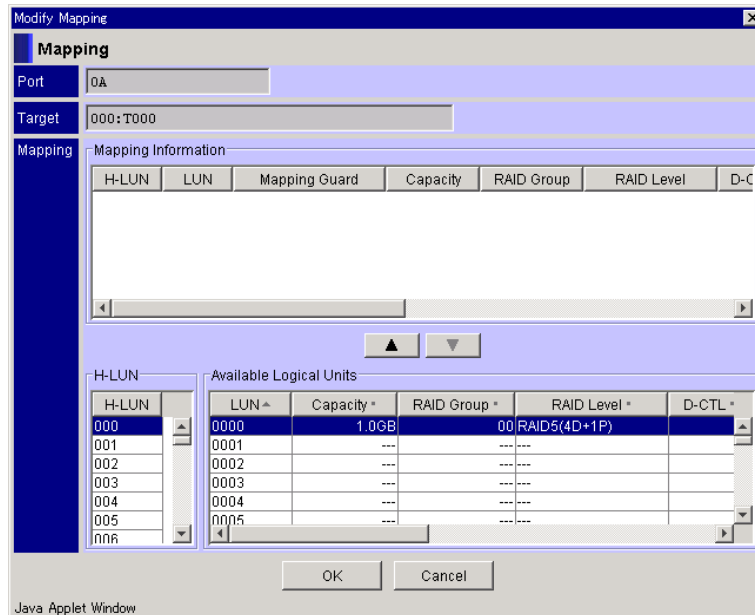

5. Select one **H-LUN** to be added. Select **LUN**, and click . The added contents display in the **Mapping Information** list.

To delete, click the line to be deleted in the **Mapping Information** list and click . The deleted contents disappear.

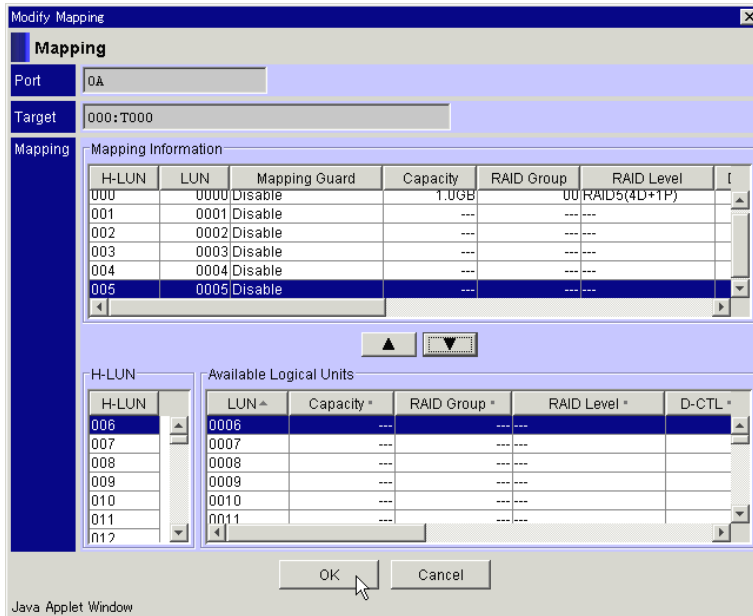

6. Click **OK**.

7. A confirmation message displays. Click **OK**.

The set mapping information is updated and the following window displays.

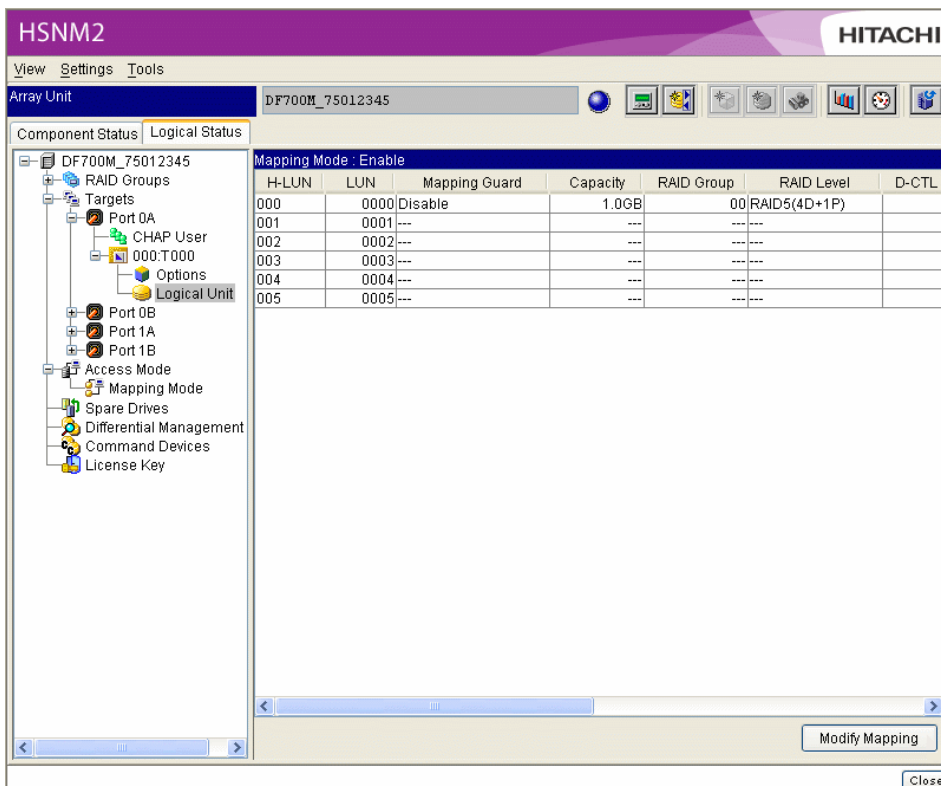

CHAP User

This section contains information about adding, changing, and deleting a CHAP user.

Adding a CHAP User

To add a CHAP User:

1. Click the **Logical Status** tab.
2. Click the **Port 0A** plus sign and select **CHAP User**.
3. Click **Add**.

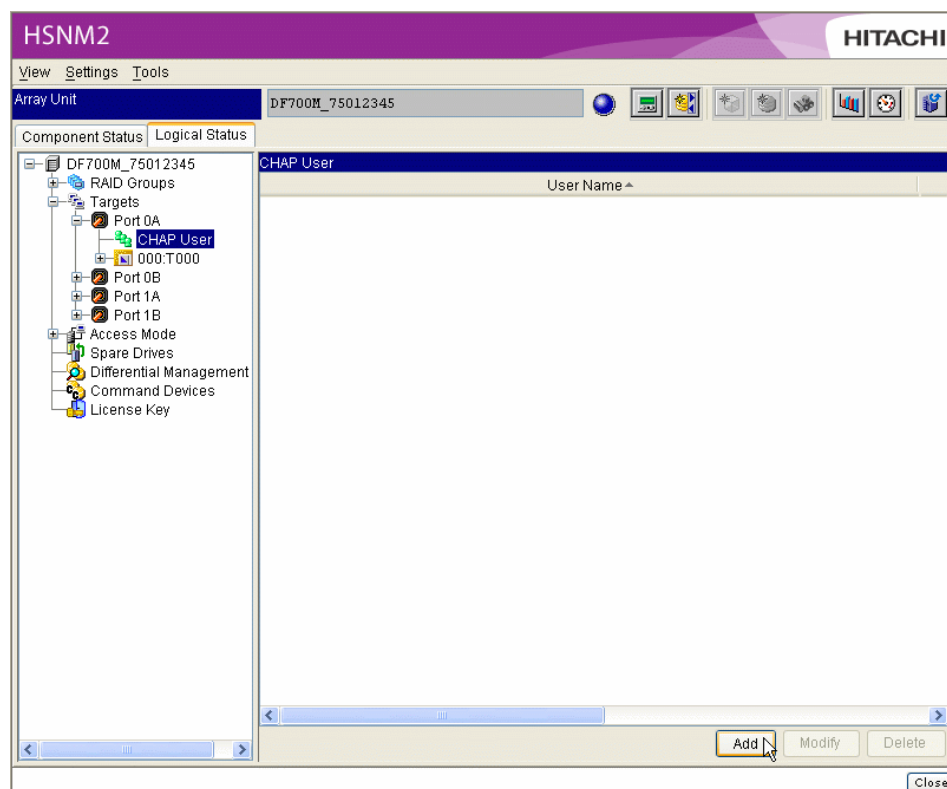

The **CHAP User** dialog box displays.

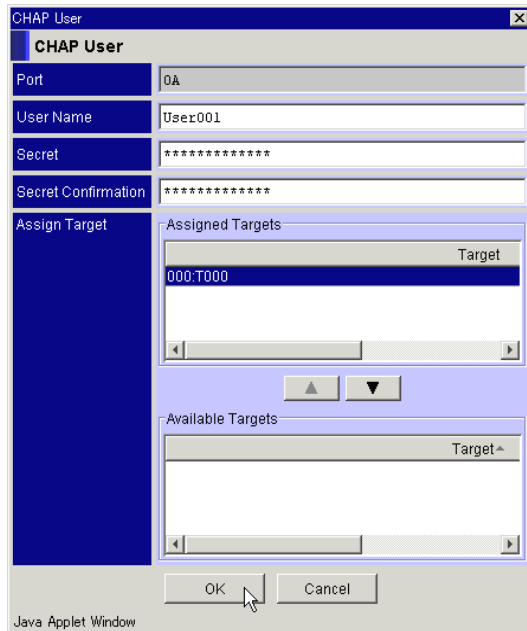

4. In the **CHAP User** dialog box, enter the **User Name**, **Secret**, and **Secret Confirmation**.
5. From the **Available Targets** list, select the target to be assigned, and click .
 - **User Name:** Enter the name of the User with 256 or less alphanumeric character. The following symbols can be used:
(. - + @ _ = : / [] ~ (space))
 - **Secret:** Enter the Secret from 12 through 32 alphanumeric characters. The following symbols can be used:
(. - + @ _ = : / [] ~ (space))
 - **Secret Confirmation:** Enter the characters that enter into the **Secret**.
6. Click **OK**.
7. A confirmation message displays. Click **OK**.

Changing the CHAP User

To change the CHAP user:

1. Click the **Logical Status** tab.
2. Click the **Port 0A** plus sign and select **CHAP User**.
3. Select the **CHAP User** to be changed from the **CHAP User** list.
4. Click **Modify**.

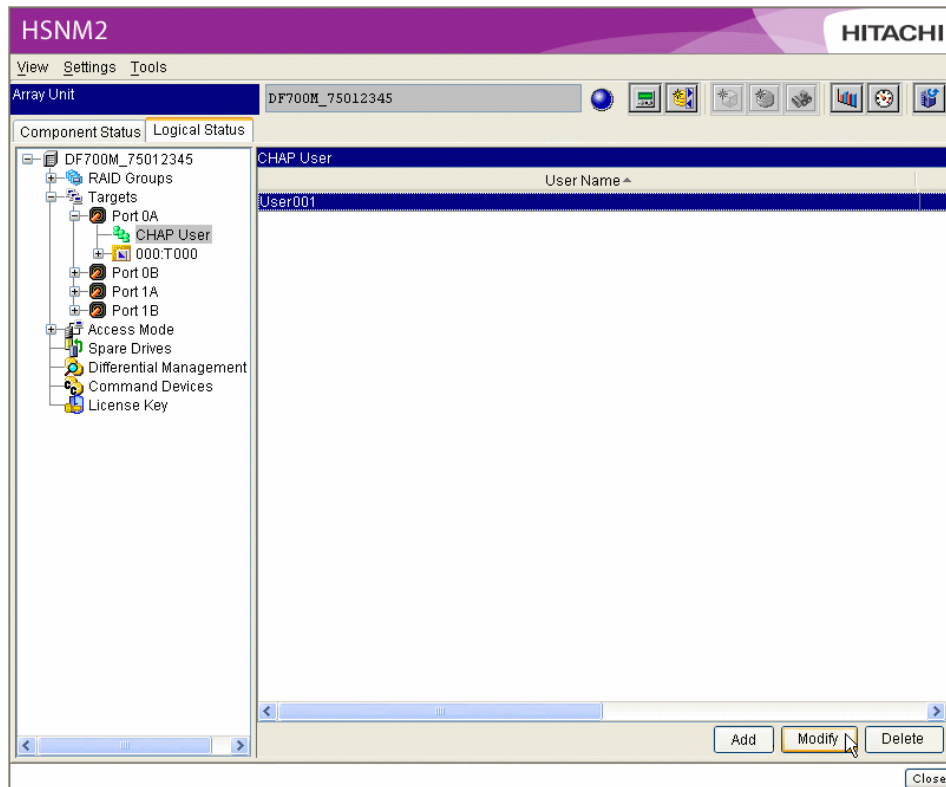

The **CHAP User** dialog box displays.

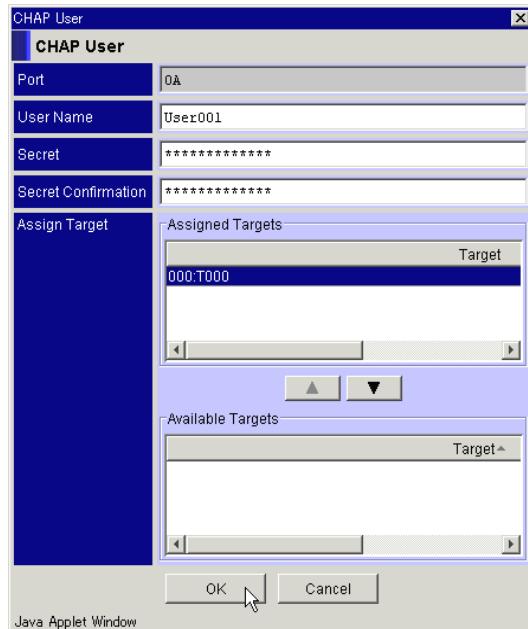

5. As necessary, enter the **User Name**, **Secret**, and **Secret Confirmation**.
6. As necessary, change the **Assigned Targets**, and click **OK**.
7. A confirmation message displays. Click **OK**.

Deleting the CHAP User

To delete the CHAP user:

1. Click the **Logical Status** tab.
2. Click the **Port 0A** plus sign and select **CHAP User**.
3. Select the **CHAP User** to be deleted from the **CHAP User** list.
4. Click **Delete**.

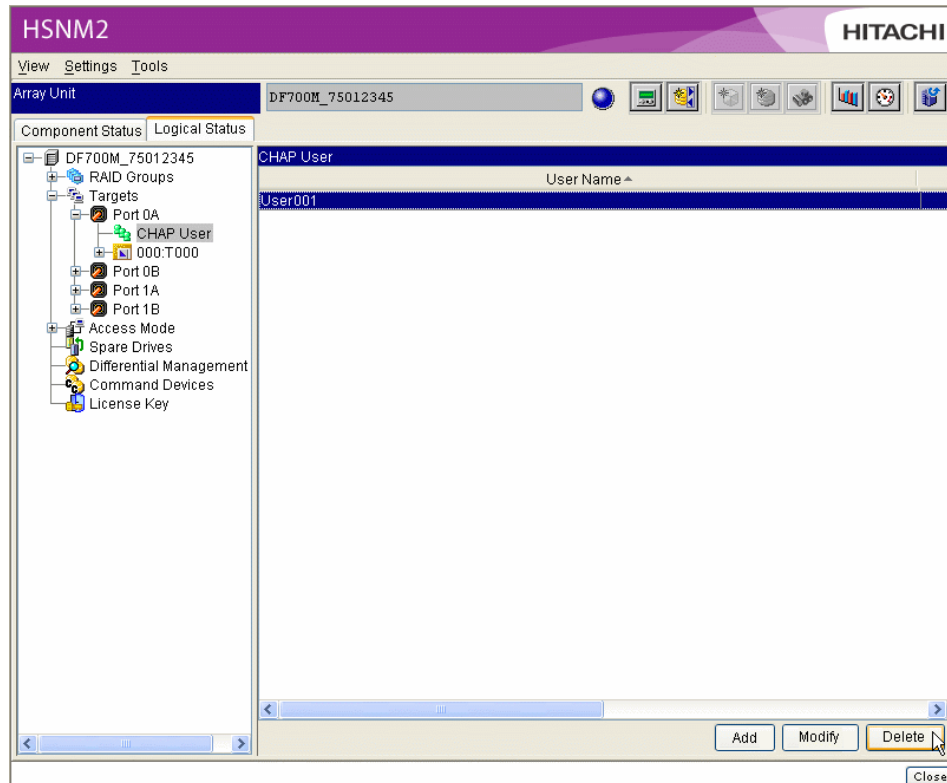

5. A confirmation message displays. Click **OK**.

Setting a Target Information

This section includes changing target information and initializing the target.

Changing Target Information

1. Click the **Logical Status** tab.
2. Click **Port 0A**.
3. Select the **Target** to be changed from the **Target** list.
4. Click **Modify**.

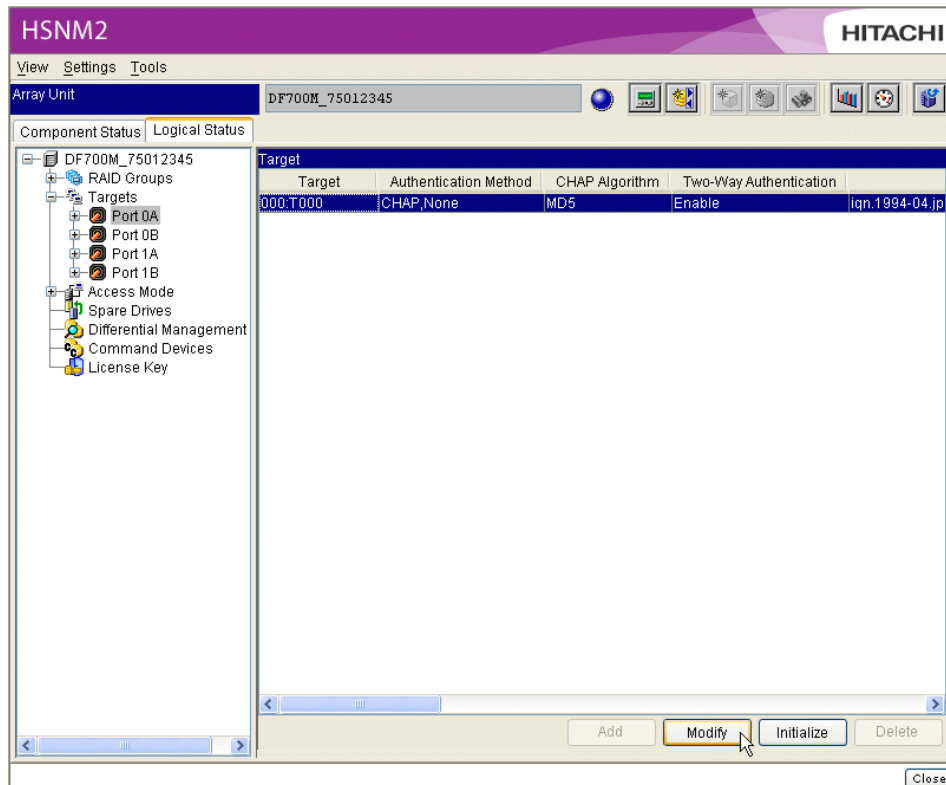

The **Target** dialog box displays.

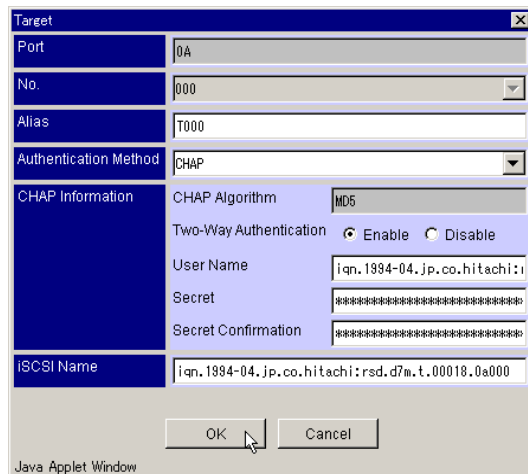

- In the **Target** dialog box, enter or select the **Alias**, the **Authentication Method**, the **CHAP Information**, the **iSCSI Name**.

- **Alias:** Enter the name of the Target with 32 or less alphanumeric character.

(Excluding \, /, :, ;, *, ?, ", <, >, | and `)

Spaces at the top or end are ignored. An identical name cannot be used in an identical Port.

- Authentication Method: Select the CHAP, None, or CHAP,None.

- CHAP Information:
 - CHAP Algorithm:** Displayed MD5 always.
 - Two-Way Authentication:** Select the **Enable** or **Disable** radio button. When the **Enable** radio button is selected, specify following items.
 - User Name:** Enter the name of the User with 256 or less alphanumeric character. The following symbols can be used:
(. - + @ _ = : / [] ~ (space))
 - Secret:** Enter the Secret from 12 through 32 alphanumeric characters. The following symbols can be used:
(. - + @ _ = : / [] ~ (space))
 - Secret Confirmation:** Enter the characters that enter into the **Secret**.
 - **iSCSI Name:** Enter the name of the iSCSI Name with 223 or less alphanumeric character. A period (.), hyphen (-), and colon (:) can be used.
6. Click **OK**.
 7. A confirmation message displays. Click **OK**.

Initializing the Target 000

1. Click the **Logical Status** tab.
2. Click the **Port**.
3. Select the **Target** to be initialized from the **Target** list.
4. Click **Initialize**.

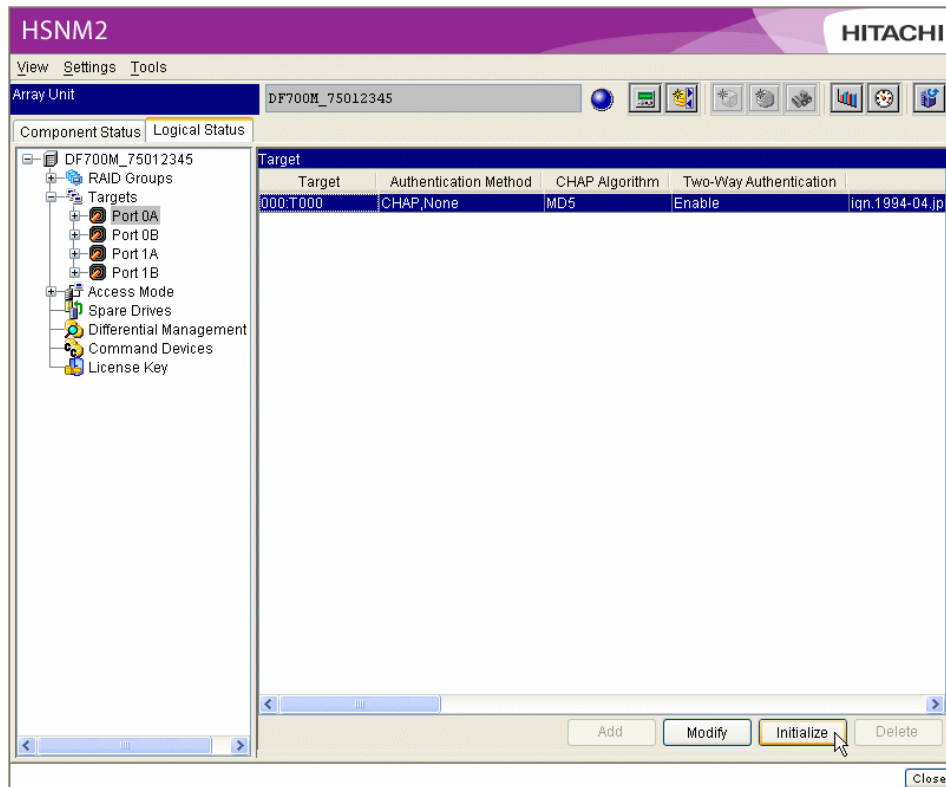

5. A confirmation message displays. Click **OK**.

Setting System Parameters

This section contains information about setting a system configuration, such as Fibre information, for an array unit. Individual items to be set are selected by switching the tab screen. Tab screens might not display, depending on the connected array unit and other variables.

Setting Boot Options

When the boot option is set, the subsystem requires a restart after setting changes.

WARNING: Rebooting requires stopping I/O from the host.

WARNING: If you are using TrueCopy or TrueCopy Extended Distance and you are required to reboot the subsystem, change the pair status to PSUS before you reboot.

WARNING: If you are using a NAS, you must also stop the clusters between NAS units. When restarting the subsystem, you must restart the clusters.

To set the boot option:

1. On the **Tools** menu, select **Configuration Settings** or click . Click the **Boot Options** tab and set the options.

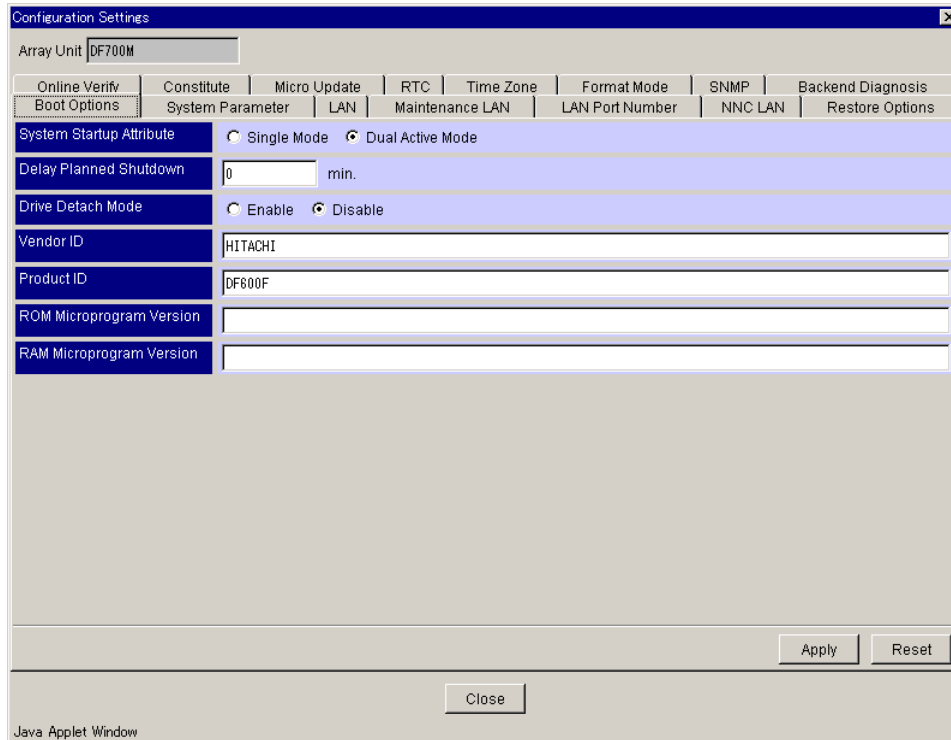

- **System Startup Attribute:** Select the subsystem configuration.

Single Mode: Single configuration

Dual Active Mode: Dual active configuration

- **Delay Planned Shutdown:** Specify the time in minutes to delay the execution of the planned shutdown when the main switch has turned off. The applicable range is from 0 to 60 minutes.
- **Drive Detach Mode:** Validates the drive blockade mode.
- **Vendor ID:** Enter an eight-character vendor name. When the name consists of less than eight characters, make an eight-character entry by filling the reset with space(s). The default value set in HITACHI△. (△ Denotes a space.)
- **Product ID:** Enter a 16-character model name. When the name consists of less than 16 characters, make a 16-character entry by filling the reset with space(s). The default value set in DF600F△△△△△△△△△△. (△ Denotes a space.)
- **ROM Microprogram Version:** Specifies a microprogram version of a ROM reported by inquiry command.
- **RAM Microprogram Version:** Specifies a microprogram version of a RAM reported by inquiry command.

2. Click **Apply**.
3. Follow the information in messages that appear. Click **OK** to continue or **Cancel**.
4. The subsystem restarts in about 4 to 15 minutes.

Setting Fibre Channel Information

Fibre channel settings include **Port Address**, **Transfer Rate**, and **Topology Information**.

Displaying Fibre Channel Information

To display fibre channel information:

1. On the **Tools** menu, select **Configuration Settings** or click .
2. Click the **Fibre Channel** tab.

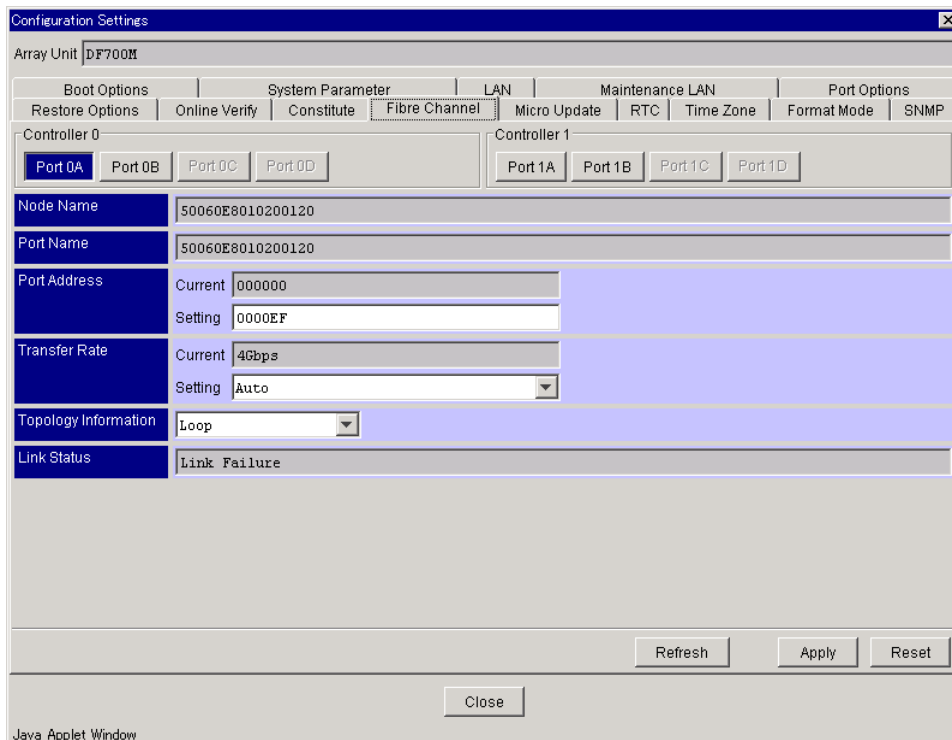

The screenshot shows the 'Configuration Settings' window for an Array Unit 'DF700M'. The 'Fibre Channel' tab is selected. The window is divided into two sections: 'Controller 0' and 'Controller 1'. Under 'Controller 0', the 'Port 0A' button is highlighted. The settings for Port 0A are as follows:

Field	Current Value	Setting Value
Node Name	50060E8010200120	
Port Name	50060E8010200120	
Port Address	000000	0000EF
Transfer Rate	4Gbps	Auto
Topology Information	Loop	
Link Status	Link Failure	

At the bottom of the window, there are buttons for 'Refresh', 'Apply', 'Reset', and 'Close'. The window title is 'Configuration Settings' and it is identified as a 'Java Applet Window'.

- **Node Name:** Describes 8 bytes of data hexadecimal (with 16 characters).
- **Port Name:** Describes 8 bytes of data hexadecimal (with 16 characters).
- **Port Address:** Port address displays as a hexadecimal number.
- **Transfer Rate:** Indicates fibre transfer rate.

- **Topology Information:** Indicates topology status.
- **Link Status:** Indicates link status.

LinkUp (Private Loop): Arbitrated Loop that is not connected with the Fibre Channel switch.

LinkUp (Public Loop): Arbitrated Loop that is connected with Fibre Channel switch.

LinkUp (N_Port connection): Connect Point to Point with host.

LinkUp (F_Port connection): Connect Point to Point with Fibre Channel switch.

Loop Port Bypass: Bypassed from the loop.

Standby: Standby state.

LinkDown: Link is down.

LinkFailure: Link initialization condition.

Setting Fibre Channel Settings

Fibre channel information is set up on a port basis.



Note: This procedure causes the subsystem to cease host access. Before setting, stop access to the port from the host.

To set the fibre channel settings:

1. On the **Tools** menu, select **Configuration Settings** or click .
2. Click the **Fibre Channel** tab.
3. Set the **Port Address**, **Transfer Rate**, and **Topology Information** making them conform to an environment that matches a host.
 - **Port Address:** Enter 8 bytes of data hexadecimal (with 16 characters).
 - **Transfer Rate:** Select the value from the drop-down menu.
 - **Topology Information:** Select the value from the drop-down menu.
4. Click **Apply**.
5. Click **OK** to continue.



Note: It may take time to complete the setting. Click **Refresh** to verify that the correct settings have been made.

Setting iSCSI Port Information

To set the iSCSI port information:

1. On the **Tools** menu, select **Configuration Settings** or click .
2. Click the **iSCSI** tab.

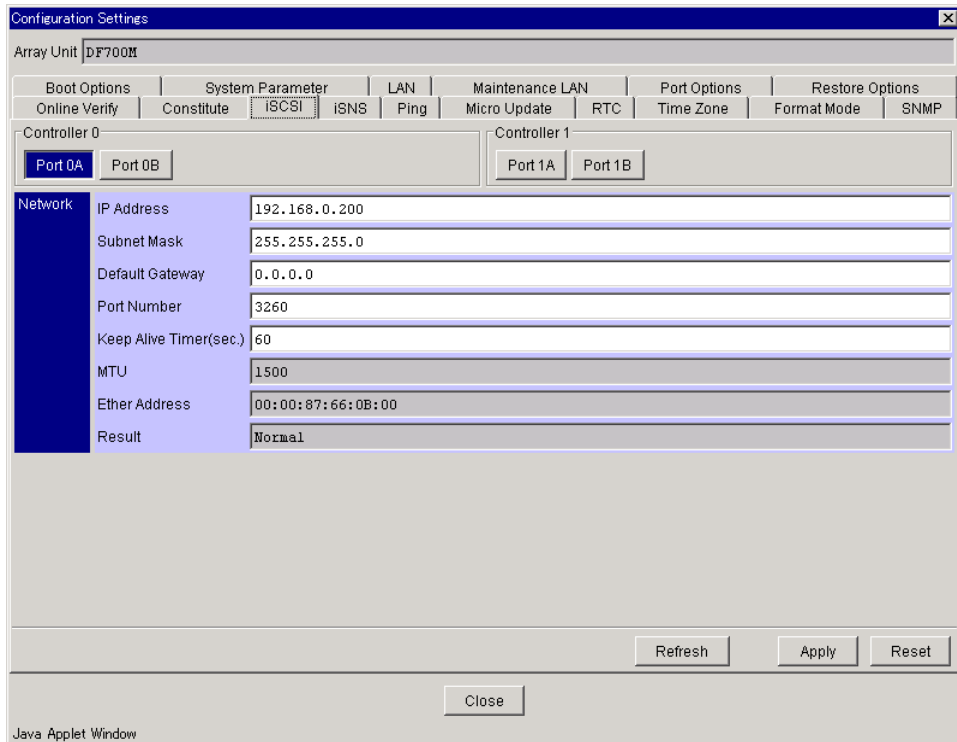

The screenshot shows the Configuration Settings window for Array Unit DF700H. The iSCSI tab is selected under the System Parameter section. The configuration is for Controller 0, Port 0A. The Network section is expanded, showing the following parameters:

Parameter	Value
IP Address	192.168.0.200
Subnet Mask	255.255.255.0
Default Gateway	0.0.0.0
Port Number	3260
Keep Alive Timer(sec.)	60
MTU	1500
Ether Address	00:00:87:66:0B:00
Result	Normal

Buttons for Refresh, Apply, Reset, and Close are visible at the bottom of the window.

3. Set the iSCSI port parameters:
 - Network: Set the IP Address, Subnet Mask, Default Gateway, Port Number, and Keep Alive Timer(sec.) making them conform to an environment.
4. Click **Apply**.
5. Click **OK** to continue.

Setting iSNS Server Information

To set the iSNS server information:

1. On the **Tools** menu, select **Configuration Settings** or click .
2. Click the **iSNS** tab.

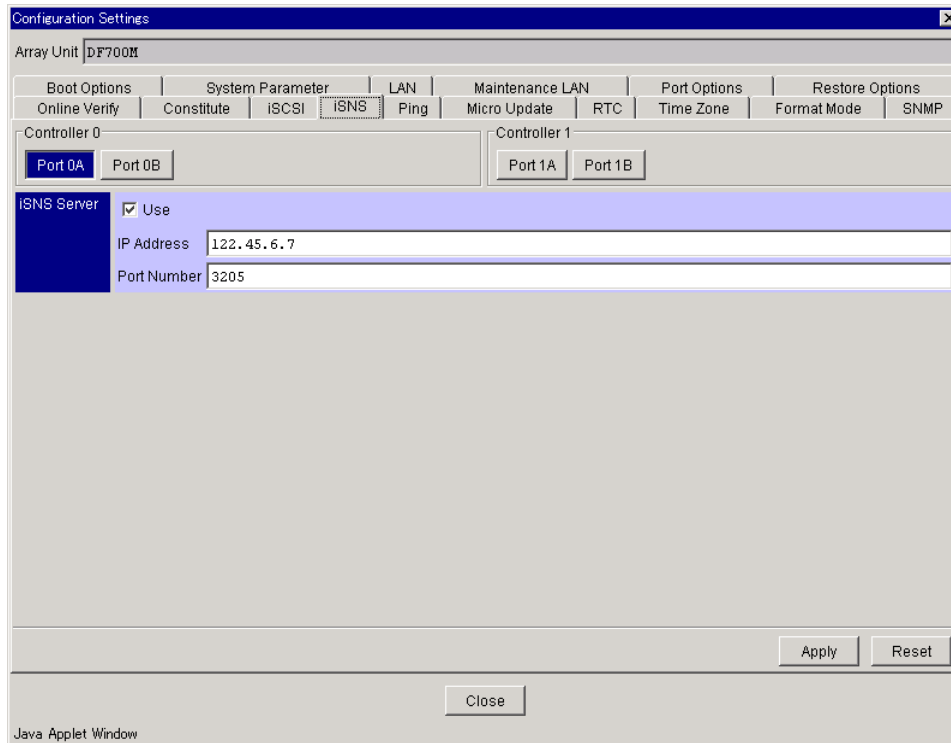

3. Set the iSNS server parameters:
 - Select iSNS Server
 - Click **Use**: Specify whether to use the iSNS server or not. When use the iSNS server, specify the **IP Address** and **Port Number** of the iSNS server.
4. Click **Apply**.
5. Click **OK** to continue.

Sending Ping

Sends the ping to the initiator (host) and displays the result of the sending.

1. On the **Tools** menu, select **Configuration Settings** or click .
2. Click the **Ping** tab.

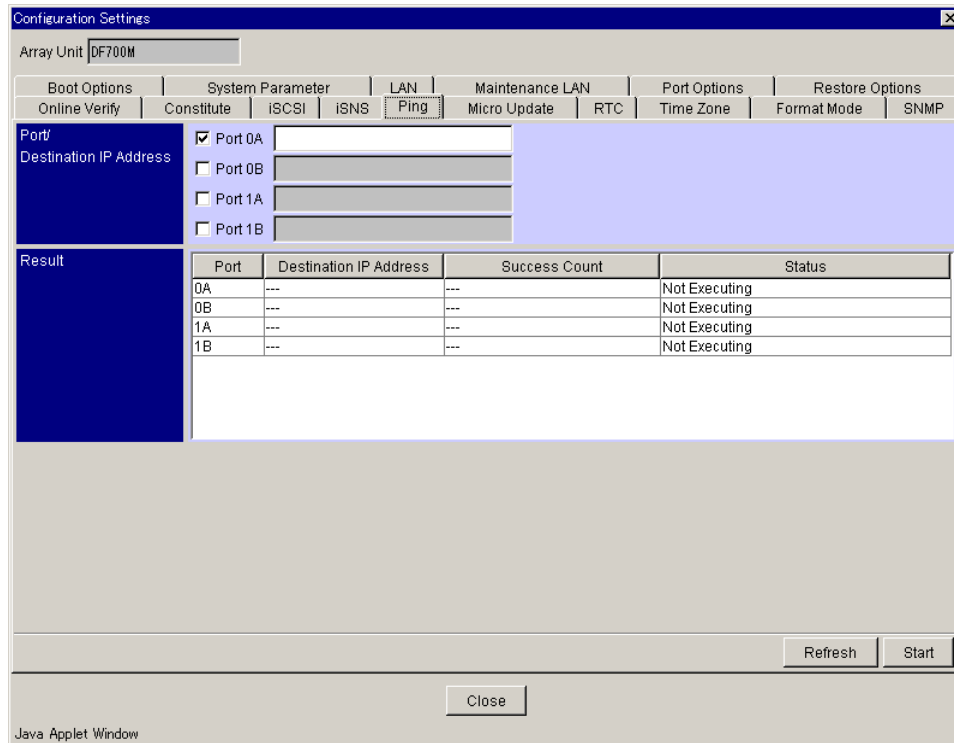

3. Set the ping parameters:
 - **Port:** Select the port that sends the ping.
 - **Destination IP Address:** Specify the IP address of the initiator.
4. Click **Start**.
5. Click **OK** to continue.

The result displays.
6. Select **Refresh** as necessary to display the latest information.

Setting System Parameters

This setting information becomes valid without restarting the subsystem.

1. On the **Tools** menu, click the **Configuration Settings** or click .
2. Click the **System Parameter** tab.

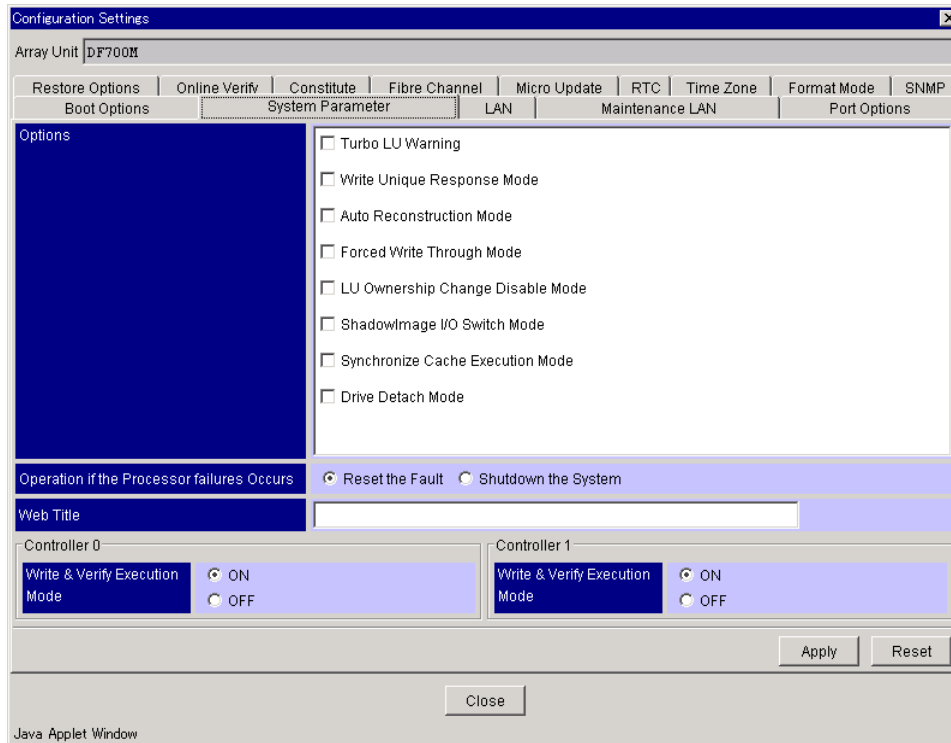

3. Set the system parameters. See Table 5.2 for a description of these parameters.
4. Click **Apply**.
5. Click **OK**.

Table 5.2 Setting System Parameters

Parameter	Description	Operation
Turbo LU Warning	This parameter is to be specified when the Turbo LU setting function is used. Default = Disable	Disable: When the Turbo LU can no longer be maintained due to a failure, the parameter allows host access to be issued. Enable: When the Turbo LU can no longer be maintained due to a failure and the performance is lowered, the parameter suppresses host access and issues a warning.
Write Unique Response Mode	This parameter is to be specified when a host of the NX series is connected. Default = Disable	Disable: Cache memory is used for write commands. Enable: Write commands are executed unconditionally in write-through mode (write data directly to disk without using cache).
Auto Reconstruction Mode	This parameter specifies operations to be performed when a disk drive is removed. Default = Disable	Disable: When a disk drive is removed, correction copy to a spare disk drive is not performed. Enable: When a disk drive is removed, correction copy to a spare disk drive is performed. Caution: This mode is for test purposes and should only be used by authorized service personnel.

Forced Write Through Mode	This parameter specifies the method for executing write commands after a CTL detachment or power failure. Default = Disable	Disable: If a CTL detachment or power failure has occurred, cache memory is used for write commands. Enable: If a CTL detachment or power failure has occurred, write commands are executed in write-through mode (write data directly to disk without using cache).
LU Ownership Change Disable Mode	This parameter specifies an operation to re-assign an LU to a non-owner controller when the controller attempts to access the LU. Default = Disable	Disable: Request internal processing to the Control Unit in charge of the LU. If there is no access for one minute from the Control Unit in charge of the LU, reallocate the Control Unit in charge of the LU. Enable: The access is always made by the Control Unit that controls the LU concerned by request, without re-assigning the LU to a Control Unit that wants to access the LU.
ShadowImage I/O Switch Mode	This parameter specifies an operation of a ShadowImage P-VOL to be performed when a double disk drive failure occurs. Default = Disable	Disable: If a double failure occurs in disk drives of a ShadowImage P-VOL in the PAIR status, the status is changed to PSUE. Enable: If a double failure occurs in disk drives of a ShadowImage P-VOL in the PAIR status, the execution of the host I/O is switched to the S-VOL to continue the execution. Note: For further information, see the ShadowImage User's Guide.
Synchronize Cache Execution Mode	This parameter specifies an operation to be performed when the Synchronize Cache command is received. Default = Disable	Disable: No operation is performed when the Synchronize Cache command is received. Enable: When the Synchronize Cache command is received, all data in the cache memory is written to disk drives. Note: For further information, see the TrueCopy User's Guide.
Drive Detach Mode	Specifies an operation to be performed when a drive failure occurs in the same RAID group. Default = Disable	Disable: When a failure occurs in a disk drive in a state in which another disk drive in the same RAID group has already been detached due to a failure, the parameter does not detach the disk drive that failed secondarily. Enable: When a failure occurs in a disk drive in a state in which another disk drive in the same RAID group has already been detached due to a failure, the parameter detaches the disk drive that failed secondarily and detaches LUs (makes LUs unformatted) in the RAID group concerned.
Operation if the Processor Failure Occurs	This parameter specifies the operation to be performed when a processor failure occurs. Default = Reset of occurred	Reset the Fault: The parameter resets the failure and reboots the Control Unit. Shutdown System: The parameter shuts the disk array subsystem down.
Web	When the Web function built in the disk subsystem is displayed with the browser, this parameter specifies characters to be displayed in the browser title bar. Default = Not set	Characters that can be entered (maximum 32) are alphabetic characters, numerals, and characters other than numerals (excluding ', ", and \).

Write & Verify Execution Mode	This parameter specifies the execution mode for write and verify operation. Default = ON	ON: The write and verify operation is performed. OFF: The write and verify operation is not performed
-------------------------------	---	--

Setting Port Options

The **Port Options** tab allows you to set the system parameter port options. The setting information becomes valid without restarting the subsystem.

1. On the **Tools** menu, click the **Configuration Settings** or click .
2. Click the **Port Options** tab.

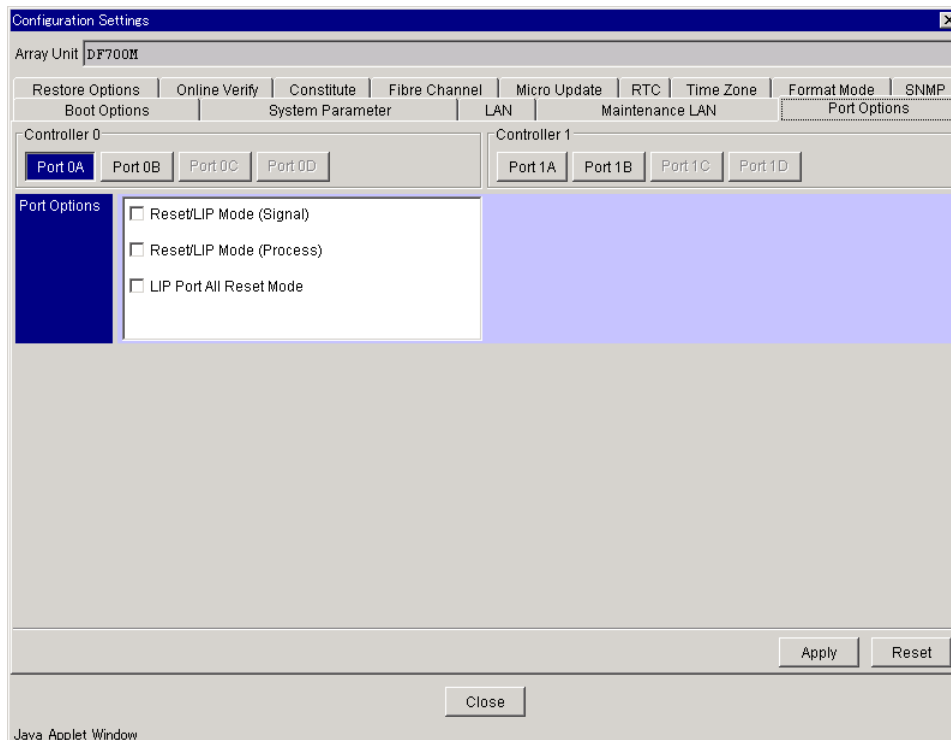

3. Select the desired port, and then select the desired **Port Options**:
 - **Reset/LIP Mode (Signal):** Set this option to transmit Reset/LIP signals to other ports.
 - **Reset/LIP Mode (Process):** Set this option to transmit reset processing to other ports. If this option is set, the **Reset/LIP Mode (signal)** is automatically enabled.
 - **LIP Port ALL Reset Mode:** Set this option to execute reset on receiving LIP.
4. Click **Apply** to apply the selected settings to the subsystem.

Setting Drive Restoration Options

Do not set drive restoration options while a drive restoration is in progress.

To set drive restoration options:

1. On the **Tools** menu, select **Configuration Settings** or click .
2. Click **Restore Options** tab.

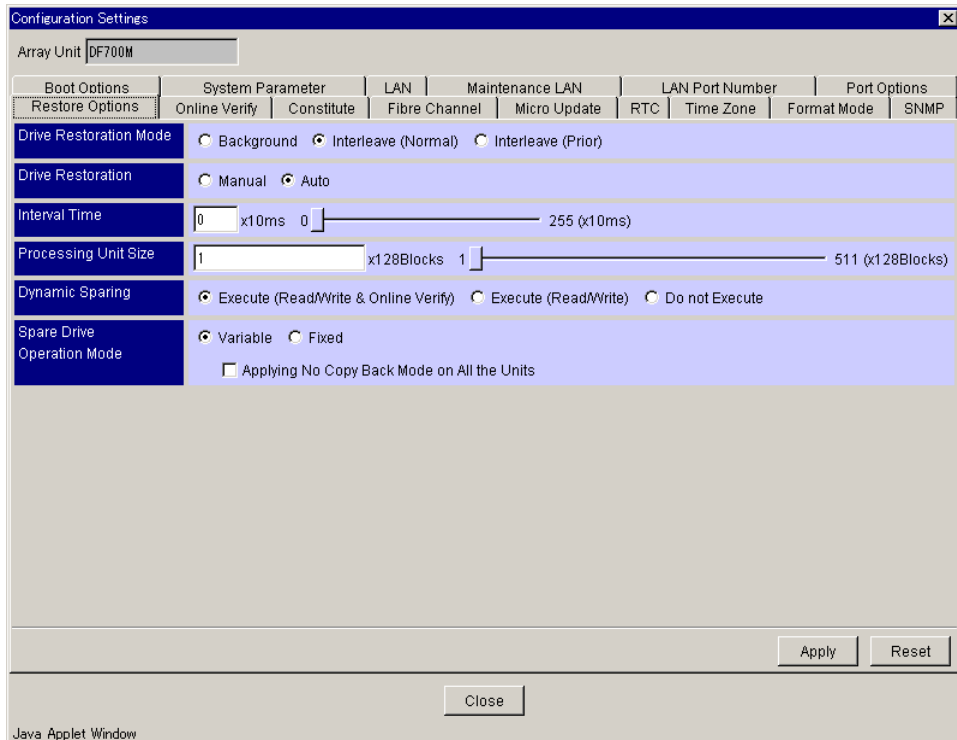

3. Enter the following settings:

Drive Restoration Mode:

- **Background:** Executes drive restoration while host I/O processing is not executed.
- **Interleave (Normal):** Restores the drive at preset time intervals (specified as "Interval Time") giving preference to a host command (restores after executing the command).
- **Interleave (Prior):** Restores the drive at preset time intervals (specified as "Interval Time") taking preference over a host command.

Drive Restoration:

- **Manual:** Starts restoring data and copying by manual operations.
- **Auto:** Automatically starts data and copying restoration.

Interval Time:

The default is 10 × 10 ms with restoration executed at intervals of 100 ms. To set, specify a multiplication factor from 0 to 255 in a unit of 10 ms.

- **Processing Unit Size:** Specify the size of the data block to be restored. The value of the range of 1 to 511 is specified by a multiple of 128. The minimum value is 128, which restores 65 KB data in a single operation. When Interleave mode is specified, the function restores the data of the processing unit size that is specified, waits for the time interval that is specified, and then starts the next data restoration.

Dynamic Sparing: Specify a mode for data restoration for the spare drive when the error occurrence count controlled by preventive maintenance exceeds the threshold value.

- **Execute (Read/Write & Online Verify):** When the error occurrence count in **Read/Write Error** or **Online Verify Error**, Threshold Value Over and Start of Dynamic Sparing display on the panel. Data restoration is performed for the spare drive (when the spare drive is not used), and the error disk is blocked.
- **Execute (Read/Write):** When the error occurrence count in **Read/Write Error** exceeds the threshold value, Threshold Value Over and Start of Dynamic Sparing displays on the panel. Data restoration is performed for the spare disk in the spare drive (when the spare disk is not used), and the error disk is blocked.
When the error occurrence count in **Online Verify Error** exceeds the threshold value, Threshold Value Over displays on the panel, but Dynamic Sparing is not performed.
- **Do not Execute:** When the error occurrence count in **Read/Write Error** or **Online Verify Error** exceeds the threshold value, Threshold Value Over displays on the panel, but Dynamic Sparing is not performed.

Spare Drive Operation Mode: Specify the spare drive operation mode.

- **Variable:** When a failed drive is replaced, the new drive becomes a spare drive.
- **Applying No Copy Back Mode on All Units:** Specify whether to set the Applying No Copy Back Mode on All Units effective or ineffective.
- **Fixed:** Uses only a drive that is designated as a spare (see section 0).

4. Click **Apply**.
5. A confirmation message displays. Click **OK**.

Online Verify Mode

To enable Online Verify Test or to Skip Online Verify:

1. On the **Tools** menu, select **Configuration Settings** or click .

2. Click the **Online Verify** tab.

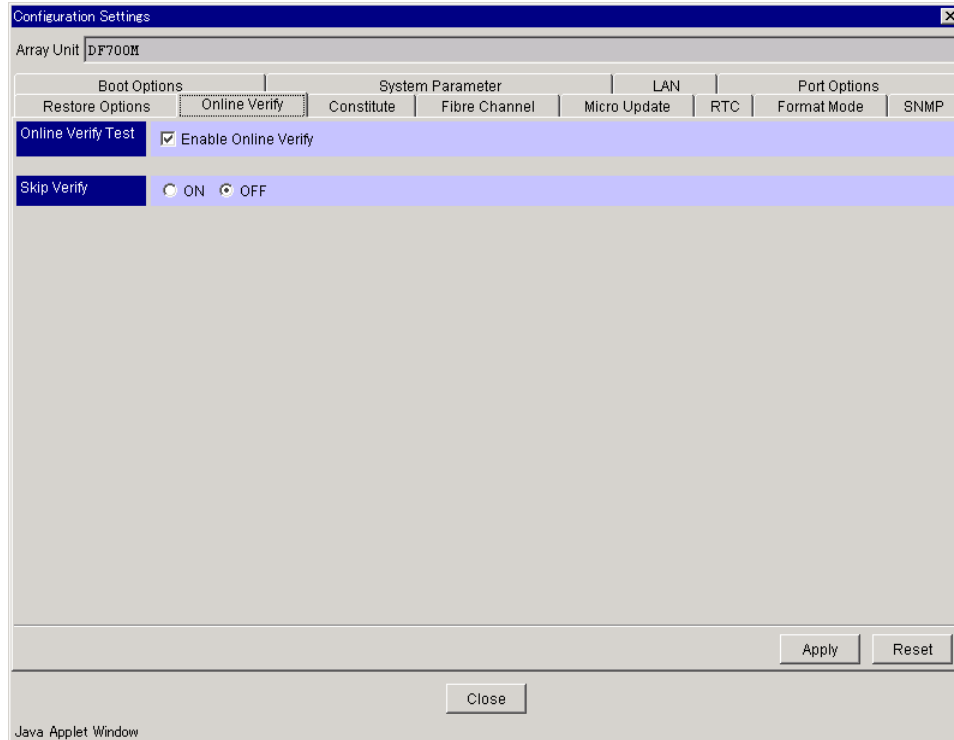

3. Select the desired options:
 - Online Verify Test
 - **Skip Online Verify:** When a verify command is received from a host, ensure that verification operation is performed.
 - **Cache Verify:** Specify whether or not to execute Cache Verify.
4. Click **Apply**.
5. A confirmation message displays. Click **OK**.

Setting Format Priority Mode

Changes to Format Priority Mode apply without restarting the subsystem.

To change the Format Priority Mode:

1. On the **Tools** menu, select **Configuration Settings** or click .
2. Click the **Format Mode** tab.

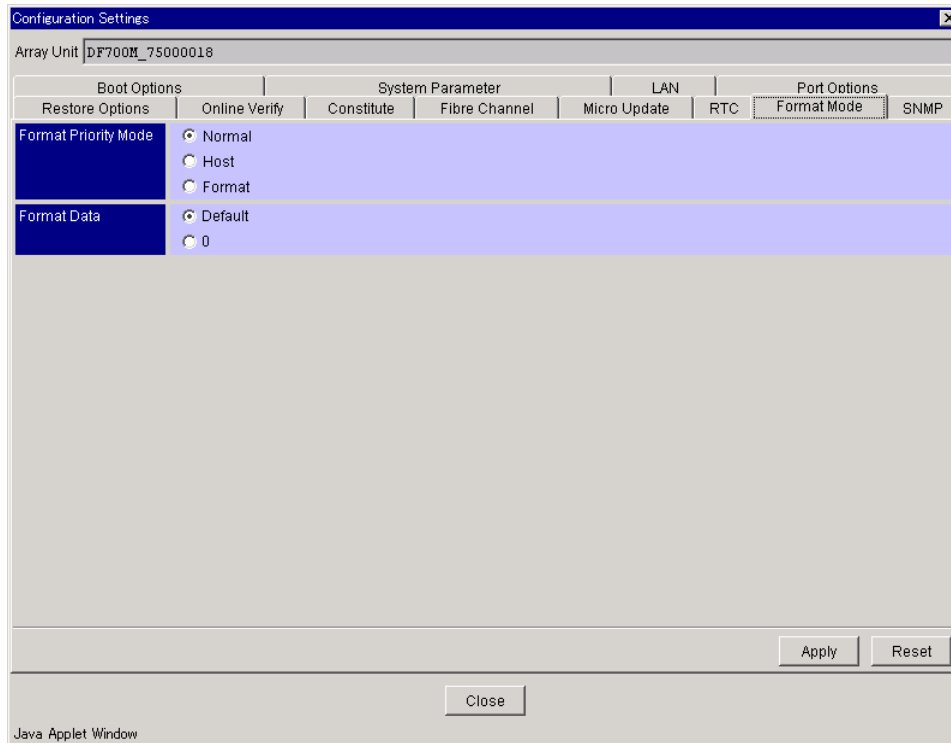

3. Select the **Format Priority** mode and **Format Data** settings.
 - Format Priority** mode:
 - **Normal:** Formats at an idle time when no host I/O is executed.
 - **Host:** Host's I/O is executed preferentially.
 - **Format:** Subsystem formats are done preferentially.
 - Format Data:** Specify a format data.
4. Click **Apply**.
5. A confirmation message displays. Click **OK**.

Setting LAN Configuration

Setting LAN Configuration without Rebooting

LAN information cannot be set when it accesses the user port and the maintenance port of the controller to be set with Web, etc. Execute LAN information after stopping access to the controller to be set.

To Set the LAN configuration without rebooting:

1. On the **Tools** menu, select **Configuration Settings** or click .
2. Click the **LAN** tab.

3. Select **Set now without reboot**.

Configuration Settings

Array Unit: DF0730/A-M

Fibre Channel | Micro Update | RTC | Time Zone | Format Mode | SNMP | Password Protection | Backend Diagnosis
Boot Options | System Parameter | LAN | Maintenance LAN | LAN Port Number | Port Options | Restore Options | Online Verify | Constitute

Set with reboot
 Set now without reboot

Maintenance Port IP Address Automatic Change Mode: Enable Disable

Controller 0

LAN

DHCP: ON

	Current	Setting
IP Address	192.168.0.100	192.168.0.100
Subnet Mask	255.255.255.0	255.255.255.0
Default Gateway	192.168.0.1	192.168.0.1
Negotiation	Auto	100Mbps/Full
Ether Address		
Result	Normal	

Controller 1

LAN

DHCP: ON

	Current	Setting
IP Address	192.168.0.101	192.168.0.101
Subnet Mask	255.255.255.0	255.255.255.0
Default Gateway	192.168.0.1	192.168.0.1
Negotiation	Auto	100Mbps/Half
Ether Address		
Result	Normal	

Refresh Apply Reset

Close

Java Applet Window

- **Set with reboot:** Rebooting is necessary.
 - **Set now without reboot:** Rebooting is unnecessary. You cannot select the DHCP mode.
 - **Maintenance Port IP Address Automatic Change Mode:** The IP address of the maintenance port is set automatically in accordance with the IP address that has been set. When the mode is set as **Enable**, the maintenance port cannot be set with the **Maintenance LAN** tab.
 - **LAN:** Specify **IP Address**, **Subnet Mask**, **Default Gateway**, and **Negotiation**, which is part of the LAN information. **Ether Address** is displayed but cannot be changed.
 - The **Setting** value and the **Current** value are displayed as the information that has been set and that is enabled in the subsystem, respectively.
4. Click **Apply**.
 5. A message displays stating that the setting is completed. To continue, click **OK**.
 6. The following message displays when the LAN information is set in the case that it accesses the user port and the maintenance port of the controller to be set with Web, etc.

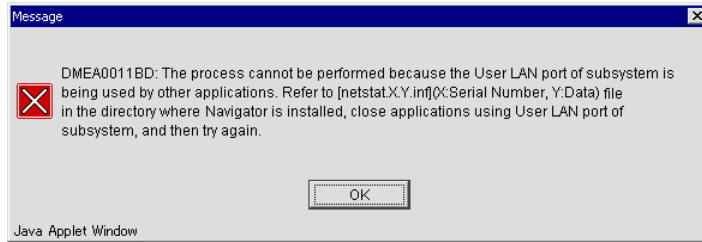

The usage condition of the LAN port is output to netstat.inf. See following figure. In the netstat.inf file, "Local address" means IP address of the controller, "Foreign Address" means IP address of PC connecting with the subsystem, "State" means the status of TCP connection. Regardless of "Status" in the netstat.inf file, stop the all application currently connecting from "Foreign address", and execute it again.

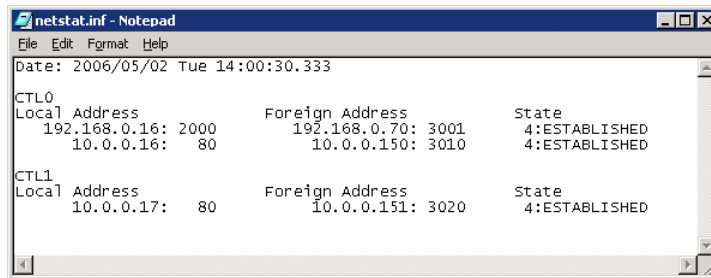

Setting LAN Configuration with Rebooting

This procedure requires restarting the subsystem.

WARNING: Rebooting requires stopping I/O from the host.

WARNING: If you are using TrueCopy or TrueCopy Extended Distance and you are required to reboot the subsystem, change the pair status to PSUS before you reboot.

WARNING: If you are using a NAS, you must also stop the clusters between NAS units. When restarting the subsystem, you must restart the clusters.

To set the subsystem LAN configuration:

1. On the **Tools** menu, select **Configuration Settings** or click .
2. Click the **LAN** tab.
3. Select **Set with reboot**.

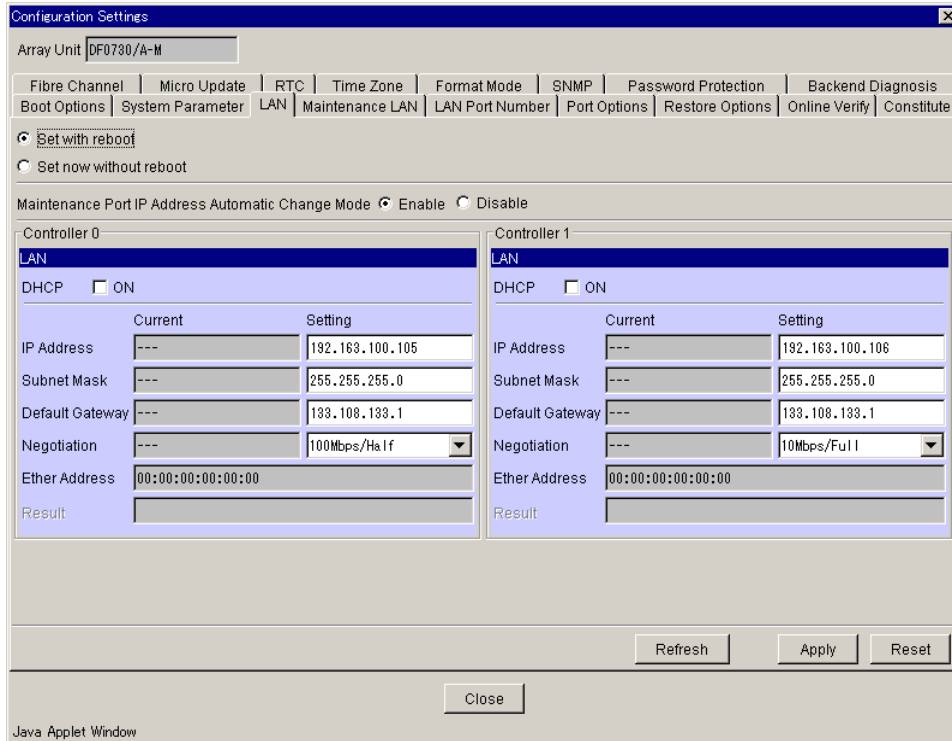

- **Maintenance Port IP Address Automatic Change Mode:** The IP address of the maintenance port is set automatically in accordance with the IP address that has been set. When the mode is set as **Enable**, the maintenance port cannot be set with the **Maintenance LAN** tab.
- **DHCP:** Specify whether the DHCP mode will be valid or invalid.
- **LAN:** Specify **IP Address**, **Subnet Mask**, **Default Gateway**, or **Negotiation**, which is part of the LAN information. **Ether Address** is displayed but cannot be changed.
- The **Setting** value and the **Current** value are displayed as the information that has been set and that is enabled in the subsystem, respectively.



Note: When **ON** is selected in **DHCP**, **Network** is disabled (gray) and cannot be selected.

4. Click **Apply**.
5. A message indicates that a subsystem restart is needed to apply the settings. Before restarting, be certain that the host is not accessing data on the subsystem. A subsystem restart takes about 4 to 15 minutes.

To continue, click **OK**.

6. A message warns that the subsystem restart can cause disruptions when using TrueCopy or TrueCopy Extended Distance: failure of TrueCopy or TrueCopy Extended Distance paths and changing pairs with PAIR or COPY status to PSUE.

To restart and apply the LAN settings, click **OK**.



Note:

- To validate the LAN information, restart the array unit. The previous settings stay valid until restarting. The array unit cannot access the host until the reboot is completed and the system restarts. Therefore, ensure that the host has stopped accessing data before beginning the restart process.
- If LAN configuration information is modified, an error message (Interface Error) may display without displaying a restart completion message when restarting is initiated. When an error message displays after the LAN configuration information is modified and a restarting is directed to be done, close the Array Unit screen, make a change in the information that has been registered through the Arrays screen, and then open the Array Unit screen again.

Setting the LAN Port Number

The port number can be set when the firmware version of the AMS/WMS array subsystem is 0726/E or later (9500V array subsystem is x65B/H or later).

The port number is set for each controller, however, set both controllers without closing the setting window. After setting the both controllers, close the Array Unit screen and edit the services file of the OS that is operating Navigator 2. When the two or more disk array subsystems are registered, set all of them. The setting of the services file is enabled without closing the Arrays screen.

Set the port number in a range of 1024 to 49151.



Note: When the TCP/IP port number is set out of a range of 1024 to 49151 and the number is already used in the management ports, it may be forcibly changed to 1024 in some cases.

When changing the TCP/IP port number of the array unit that is connected over a LAN, register the changed port number as "df-damp-snm port number/TCP". Before starting Navigator 2, you must register the changed port number in the services file of the OS on which Navigator 2 is installed. If it is not registered, the array unit may not be able to be connected to the LAN.

Table 5.3 Registering a Changed TCP/IP Port Number

Array Unit	Firmware Version
Simple Modular Storage 100	1810/A or later
Adaptable Modular Storage 2100/2300	0832/B or later
Adaptable Modular Storage 2500	0840/A or later

1. On the **Tools** menu, select **Configuration Settings** or click .
2. Click the **LAN Port Number** tab.

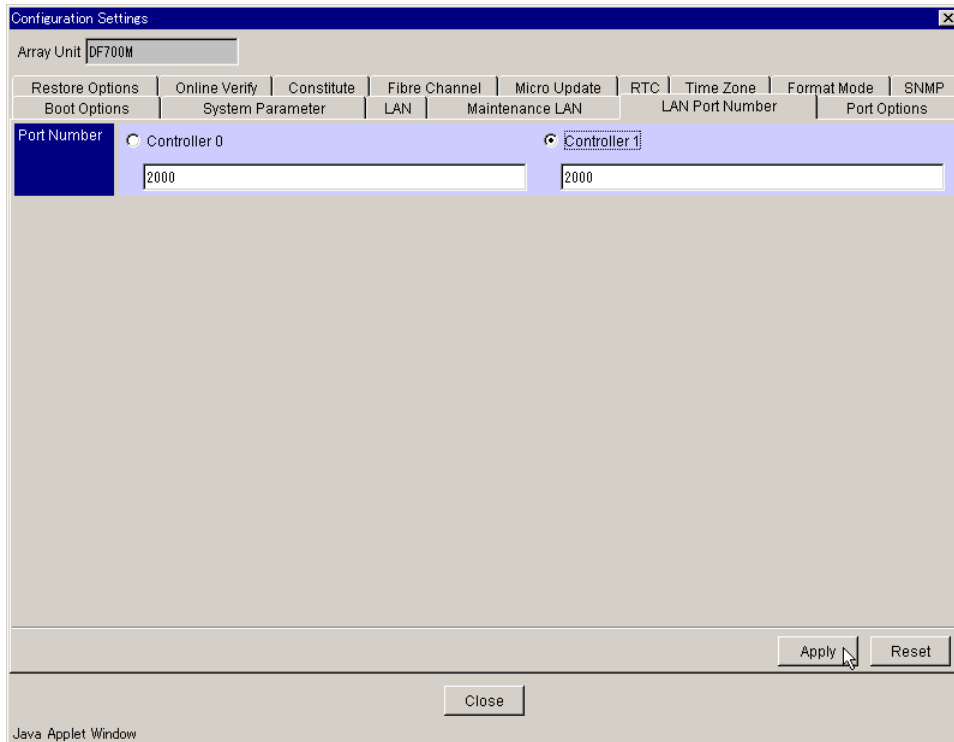

3. Select the radio button of **Controller1** and enter a port number in the port number text field.



Note: Enter a port number that is not used by the OS that is operating Navigator 2, various types of applications, etc. in the port number field.

4. Click **Apply**.
5. When the confirmation message displays, click **OK** (three times).
6. When the following confirmation message displays, click **Cancel**.

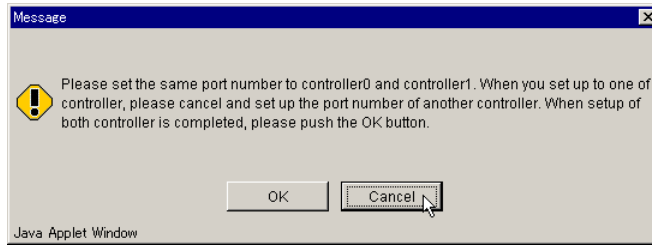

Navigator 2 goes to the **LAN Port Number** tab screen.

7. Select the radio button of the **Controller0** and enter a port number to be set in the port number text field. Enter the port number that is set in the **Controller1**.
8. Click **Apply**.
9. When the confirmation message displays, click **OK** (five times).
The Array Unit screen is closed.

An example of the edit of the services file (in the case of Windows 2000):

1. Open the services file using a text editor such as `Notepad.exe`, etc.
2. Add a port number to be used by Navigator 2 referring to the following example, and then overwrite and save it.

When adding the port number to the last line, ensure that you start a new line.

```
# Copyright (c) 1993-1999 Microsoft Corp.
#
# This file contains port numbers for well-known services defined by IANA
#
# Format:
#
# <service name> <port number>/<protocol> [aliases...] [#<comment>]
#
echo          7/tcp
echo          7/udp
:
:
radacct      1813/udp          #RADIUS accounting protocol
nfsd        2049/udp      nfs          #NFS server
knetd       2053/tcp          #Kerberos de-multiplexor
man         9535/tcp          #Remote Man Server
df-damp-snm 23456/tcp
```

Setting the IP Address of the Maintenance Port



Note: The LAN configuration information for the maintenance of the subsystem is usually set at the factory shipment; therefore you do not have to set it.

To set the IP address of the maintenance port:

1. On the **Tools** menu, select **Configuration Settings** or click .
2. Click the **Maintenance LAN** tab.

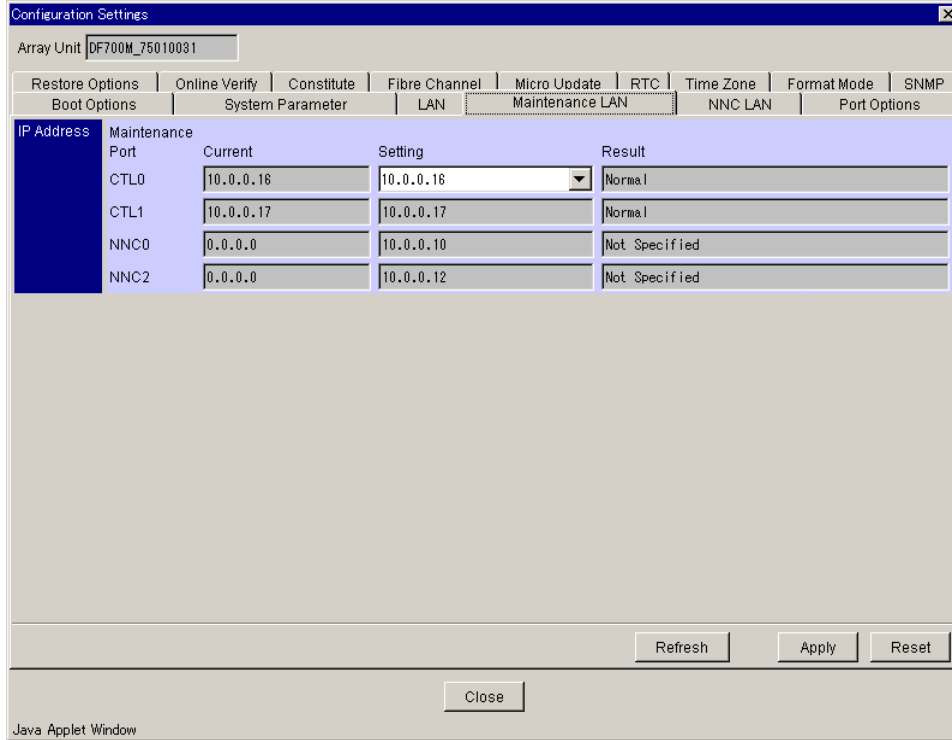

- **IP Address:** Select the IP address of the CTL0 from the drop-down list. When the **Maintenance Port IP Address Automatic Change Mode** is set as **Enable** with the **LAN** tab, the display is grayed and the setting cannot be made.

3. Click **Apply**.
4. When the confirmation message displays, click **OK**.

Setting RTC

Changes to the RTC apply without restarting the subsystem.

To set the RTC:

1. On the **Settings** menu, click the **Configuration Settings** or click .
2. Click the **RTC** tab.

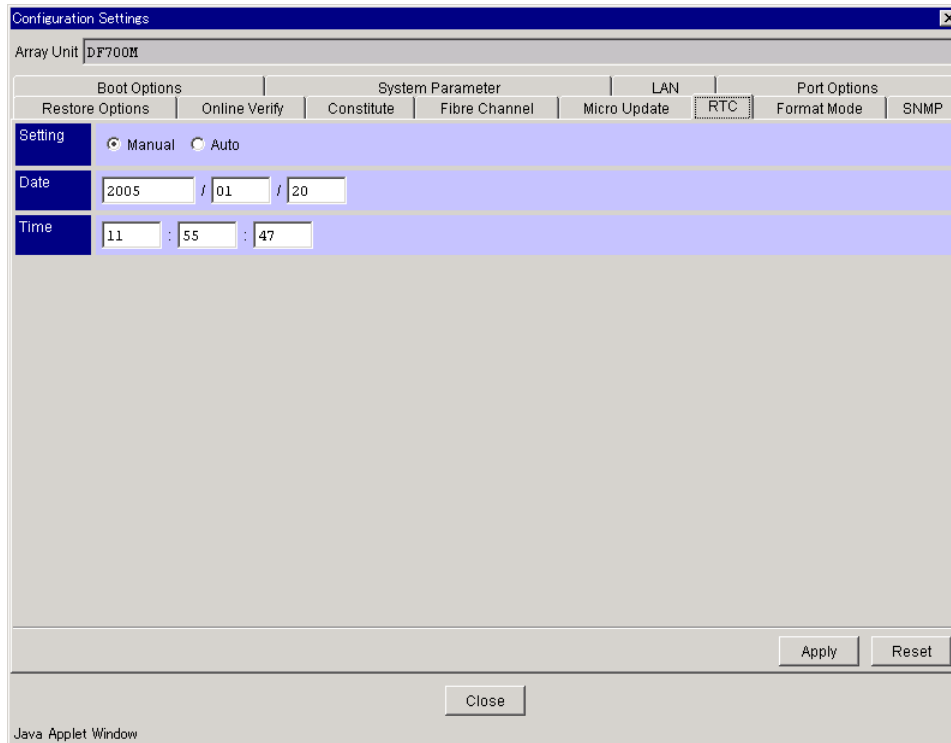

3. Set the RTC:
 - **Setting:** Select Manual or Auto.
 - **Manual:** Sets the date and time.
 - **Auto:** Sets the time of the Web Server executing Navigator 2.
 - **Date:** Displays the date.
 - **Time:** Displays the time.
4. Click **Apply**.
5. A confirmation message displays. Click **OK**.

Setting Time Zone and NTP Server

To set the time zone:

1. On the **Tools** menu, select **Configuration Settings** or click .
2. Click the **Time Zone** tab.

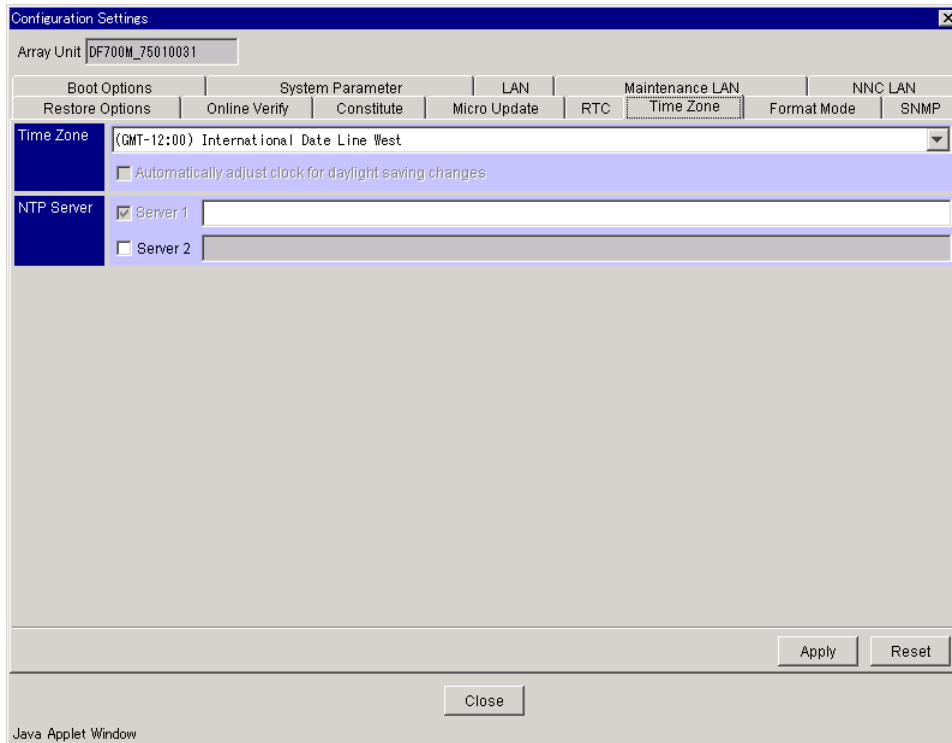

- **Time Zone:** Select a time zone from the **Time Zone** drop-down list.
 - Automatically adjust clock for daylight saving changes: Specify whether to use the daylight saving or not.
 - **NTP Server:** Specify the IP address of the NTP server.
3. Click **Apply**.
 4. When the confirmation message displays, click **OK**.

Outputting Configuration Information to a File

This section describes how to output the configuration information of the subsystem in a text file or set the configuration using a text file.

The configuration information output in a text file includes the status of the system parameters, RAID group/logical unit, port/host group, and the constituent parts of the subsystem. The configuration to be set includes the system parameters, RAID group/logical unit, and port/host group. The status of the constituent parts of the subsystem cannot be set.

The configuration information is handled with separate text files for the system parameters, for RAID group/logical unit, and for port/host group.

Copying configuration information between subsystems can be executed by outputting a text file of the configuration from the subsystem, then using the output text file to set another subsystem.

Editing a text file to set the subsystem can be done, however, it is recommended that this function be used for the configuration of the same subsystem. To change the configuration, use individual functions.

File Output for System Parameters

To output the settings of the system parameters for the subsystem in text form to a specified file:

1. On the **Tools** menu, select **Configuration Settings** or click .
2. Click the **Constitute** tab.

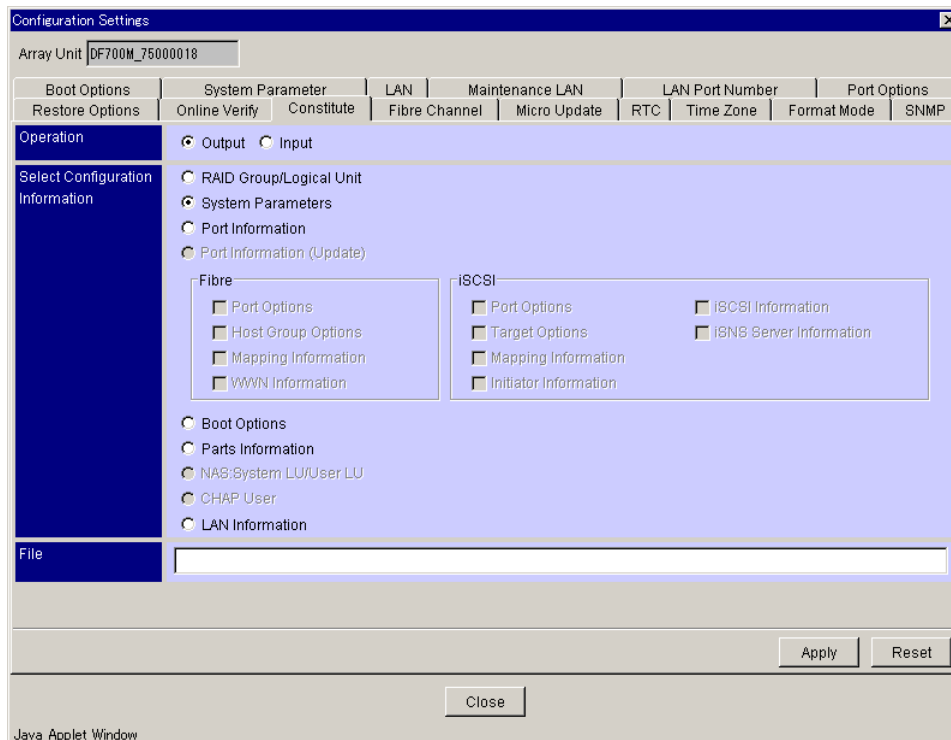

3. Check the **System Parameters** option in the **Select Configuration Information** box.
4. Specify the directory and file name to which the configuration file will be output.
5. Select the **Output** option.
6. Click **Apply**.
7. When the confirmation message displays, click **OK**.

System parameter information is saved in the form of a text file with the specified file name. The format of the output file consists of the following items. The outline of the layout of the output file is shown in following figure.

- File header

- Subsystem registration name with Navigator 2
- Output time (Web Server time where Navigator 2 is installed)
- Firmware revision
- Subsystem type
- Serial number
- Common controller parameters
- Controller parameters

System parameter list.

```
DF Name : DF700M_75000026
Date : 2007/11/30 15:21:52
Firmware Revision : 0720/A-M
Array Unit Type : DF700M
Serial Number : 75012345

---- System Parameter ----
Options
Turbo LU Warning = OFF
Write Unique Response Mode = OFF
Auto Reconstruction Mode = OFF
Forced Write Through Mode = OFF
LU ownership Change Disable Mode = OFF
ShadowImage I/O Switch Mode = OFF
Synchronize Cache Execution Mode = OFF
Drive Detach Mode = OFF
Operation if the Processor failures occurs = Reset the Fault
Web Title = ""
---- CTL0 Parameter ----
write & Verify Execution Mode = ON
---- CTL1 Parameter ----
write & Verify Execution Mode = ON
```

Setting System Parameters with a File

Set the system parameters in the subsystem with the information described in the file. If you set the system parameters using a file that was output when a priced optional feature is in an unlocked state, the setting may terminate abnormally. To set system parameters, use a file that was output when all priced optional features are in a locked state.

For a dual system, setting cannot be executed if one of the controllers is detached. Verify that the subsystem is operating normally.

When system parameters are set, the subsystem cannot execute commands from the host. The functions of Navigator 2 can no longer work; however, the wizard sets the system parameters and failure monitoring. After setting, restart the subsystem. Confirm that it is operating successfully. It connects to the host and Navigator 2.

To set subsystem parameters with a file:

1. Edit the file for setting the system parameters to set the subsystem. The file has a specified format. The format of the file is the same as that of the file output by the subsystem. Refer to the following sections of this manual for the format and parameters of the file respectively.

For the format of the file, see section 0.

2. On the **Tools** menu, select **Configuration Settings** or click .
3. Click the **Constitute** tab.
4. Click the **System Parameter** option.
5. Specify the directory and file name of the file that describes the system parameters edited in step 1. The specified file name displays in the text box.
6. Select the **Input** option.
7. Click **Apply**.
8. When the confirmation message displays, click **OK**.

RAID/Logical Units and Configuration File Output Status

To output RAID group/logical unit definition information already set in the subsystem to a specified file in a text format:

1. On the **Tools** menu, select **Configuration Settings** or click .
2. Click the **Constitute** tab.

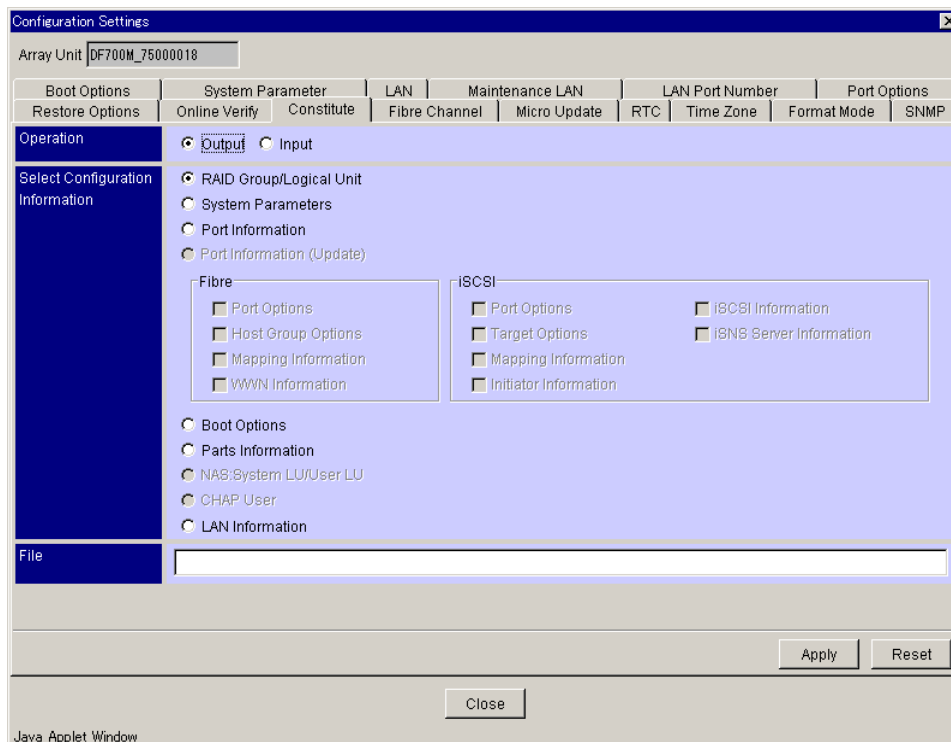

3. Click the **RAID Group/Logical Unit** option in the **Select Configuration Information** box.
4. Specify the directory and file name to output the file of the configuration.

5. Select the **Output** option.
6. Click **Apply**.
7. When the confirmation message displays, click **OK**.

System parameter information is saved in the form of a text file with the specified file name.

The format of the output file consists of the following items. An outline of the layout of the output file is shown in following figure.

- File header
- Subsystem registration name at Navigator 2
- Output time (Web Server time where Navigator 2 is installed)
- Firmware revision
- Subsystem type
- Serial number
- RAID group/logical unit configuration
- Status of constituent parts

Array unit configuration information list.

DF Name : DF700M_75000026
 Date : 2007/11/30 15:30:38
 Firmware Revision : 0720/A-M
 Array Unit Type : DF700M
 Serial Number : 75012345

```

---- RAID Configuration Information ----
---- RAID Configuration ----
RAID RAID Start Location Number of HDU Number of Free Capacity Type
Group Level [Unit No. HDU No.] in parity group parity group [block]
0 5 0 0 5 5 1 134217728 FC
1 5 0 0 5 5 1 268435456 FC

-- End

---- Drive Location of RAID Group ----
RAID Group Drive Location(Unit No.-HDU No.)
0 0-0 0-1 0-2 0-3 0-4
1 0-5 0-6 0-7 0-8 0-9

-- End
-- End

---- LU Configuration Information ----
LU Capacity Status Staging Number of Number of RAID RAID Number of Stripe Size Capacity Type
No. [block] [block] Current CTL Default CTL Group Level Cache Partition [KB] [MB/GB]
0 65535 Normal 512 0 0 0 5 0 64 31.9 MB FC
1 65535 Normal 512 0 0 0 5 0 64 31.9 MB FC

-- End

---- Drive Configuration Information ----
Location Status Type Vendor ID Product ID Revision Serial Number Capacity Drive Type
Unit0 ,HDU0 Normal Data HITACHI DISK-DRIVE 0AA0 U00-H00- 500GB FC
Unit0 ,HDU1 Normal Data HITACHI DISK-DRIVE 0AA0 U00-H01- 500GB FC
Unit0 ,HDU2 Normal Data HITACHI DISK-DRIVE 0AA0 U00-H02- 500GB FC
Unit0 ,HDU3 Normal Data HITACHI DISK-DRIVE 0AA0 U00-H03- 500GB FC
Unit0 ,HDU4 Normal Data HITACHI DISK-DRIVE 0AA0 U00-H04- 500GB FC

-- End
  
```

Setting RAID Group/Logical Unit Definition with a File

Set the subsystem according to the RAID group/logical unit setting information described in a file. If the setup of the RAID group/logical unit is configured and completed, all of the previous user's data will be lost. The RAID group/logical unit capacity configuration, as specified in the file, is set after deleting the current RAID group/logical unit. If user data is needed, configure the setting after backing up the system.

1. Edit the file to set the RAID group/logical unit information in the subsystem. The file has a specified format. The format of the file is the same as that of the file output by the subsystem. For the proper file format, see section 0.

The parameters in the file are **RAID configuration information**, **LU configuration information**, and **Drive information** in the format of the output file. In the output file, there are items that give the status of constituent parts. Ignore these items while setting up the configuration. The parameters are described below:

- a) **RAID configuration information:** Sets the RAID configuration which specifies RAID level, RAID group number and RAID size. If the RAID group is not set, "-" is shown after **Level**, and no other parameters are set.

- b) **LU configuration information:** Sets the logical unit configuration.

Specify the logical unit number, logical unit capacity, pre-read capacity, number of controllers in current use, number of controllers in default use, RAID group number and RAID level, and logical unit status.

In logical unit status, for cases where formatting is to be executed, specify **Normal**. Formatting cannot be executed if another status is specified.

In cases where the full capacity of the RAID group is allocated to one logical unit, specify **All** in **Capacity**.

If the number of the controller in current use is specified as "0" or "1", it becomes the same as the number of the controller in default use.

In cases where logical units of less than the maximum logical unit number are created, specify at the end that "After nn, not define" (nn: the last logical unit number + 1).

- c) **Drive information:** Sets the configuration of the HDU installed in the subsystem. For an HDU that is not installed, do not specify anything.

When a capacity bigger than that of the installed HDU is specified, it is regarded as an error and not set.

2. On the **Tools** menu, select **Configuration Settings** or click .
3. Click the **Constitute** tab.
4. Click the RAID **Group/Logical Unit** option.
5. Specify the directory and name of the file that describes the RAID group definition and logical unit definition edited in step 1. The specified file name is shown in the text box.
6. Select the **Input** option.
7. Click **Apply**.
8. Messages display and warn you of the following:
 - The procedure deletes the current RAID/LU configuration.
 - User data in the logical units are invalidated and cannot be recovered.To continue, click **OK** in the messages.
9. A message displays, stating that the RAID configuration setting has started:
 - When the setting of the RAID group ends abnormally, an error message displays and interrupts processing.
 - If the setting of the RAID group ends normally, a message that the setting of logical unit has started displays, and executes the logical unit setting.
 - When the logical unit setting ends abnormally, an error message displays and interrupts processing.
 - If the logical unit setting ends normally, formatting of the set logical unit starts.
10. A message displays stating that the setting is complete. Click **OK**.

Port/Host Group Information File Output

To output the settings of the port/host group information for the subsystem in text form to a specified file:

1. On the **Tools** menu, select **Configuration Settings** or click .
2. Click the **Constitute** tab.

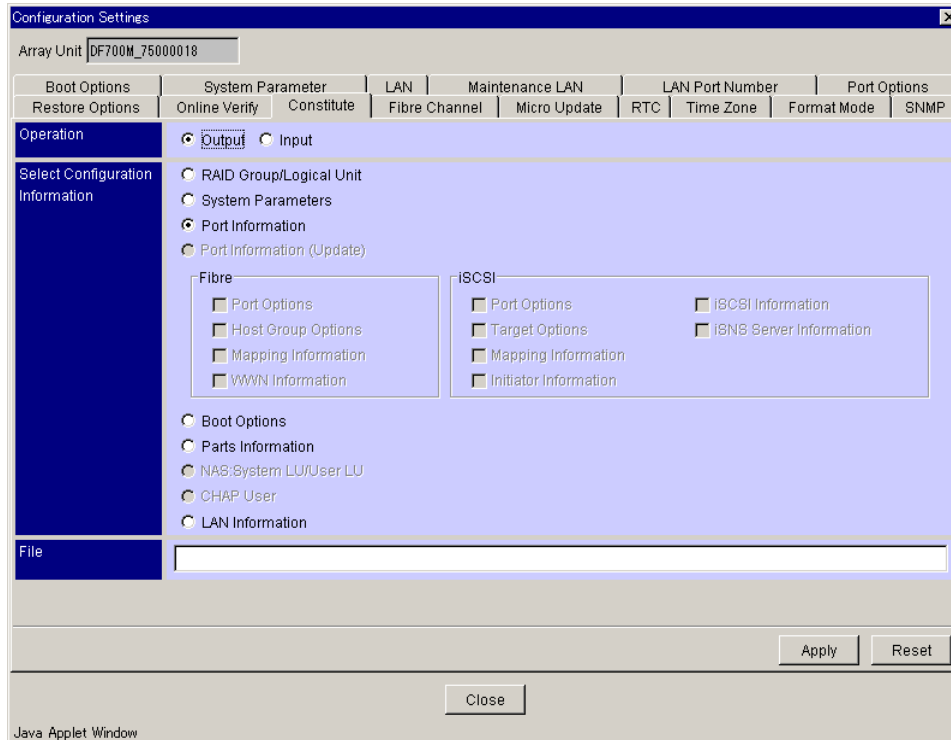

3. Check the **Port Information** option in the **Select Configuration Information** box.
4. Specify the directory and file name to which the host group information file will be output.
5. Click the **Output** option.
6. Click **Apply**.
7. When the confirmation message displays, click **OK**.

The host group information is saved in the form of a text file with the specified file name.

The format of the output file consists of the following items. The outline of the layout of the output file is shown in following figure.

- File header
- Registration name with Navigator 2 of the subsystem

- Output time (Web Server time where Navigator 2 is installed)
- Firmware revision
- Subsystem type
- Serial number
- Mapping mode
- Port option
- Host group option
- Host group information
- Logical unit mapping information

Configuration Information list.

```

DF Name : DF700M_75000026
Date : 2007/11/30 15:34:58
Firmware Revision : 0720/A-M
Array Unit Type : DF700M
Serial Number : 75012345

---- CommonInformation ----
MappingMode = ON

---- CTL0 ----
---- PortA ----
PortType = Fibre
---- PortOptions ----
Reset/LIP Mode(Signal) = OFF
Reset/LIP Mode(Process) = OFF
LIP Port All Reset Mode = OFF

---- HostGroupList ----
---- HostGroupInformation ----
HostGroupNumber = 0
HostGroupName = "G000"

---- HostSystemConfiguration ----
Platform = not specified
Alternate Path = not specified
Failover = not specified
Additional Parameters
None

---- HostGroupOptions ----
Host Connection Mode 1 = Standard Mode
Host Connection Mode 2
HP-UX Mode = OFF
PSUE Read Reject Mode = OFF
UA(06/2A00) suppress Mode = OFF
NACA Mode = OFF
HISUP OFF Mode = OFF
Reset Propagation Mode = OFF
Unique Reserve Mode 1 = OFF
ASL Report Mode(Active/Passive Group) = OFF
ASL Report Mode(Active/Passive) = OFF
ASL Report Mode(Active/Active) = OFF
Port-ID No Report Mode = OFF
Port-ID Conversion Mode = OFF
Tru Cluster Mode = OFF
Product Serial Response Mode = OFF
Same Node Name Mode = OFF
CCHS Mode = OFF
SPC-2 Mode = OFF

---- LuMapping ----
H-LUN LUN
-- HostGroupInformationEnd
-- HostGroupListEnd

--- LUNManagementInformation ---
Security = OFF
---- PermissionList ----
-- PermissionListEnd

```

Setting Port/Host Group Information with a File

To set Port/Host Group settings with a file:

1. On the **Tools** menu, select **Configuration Settings** or click .

2. Click the **Constitute** tab.

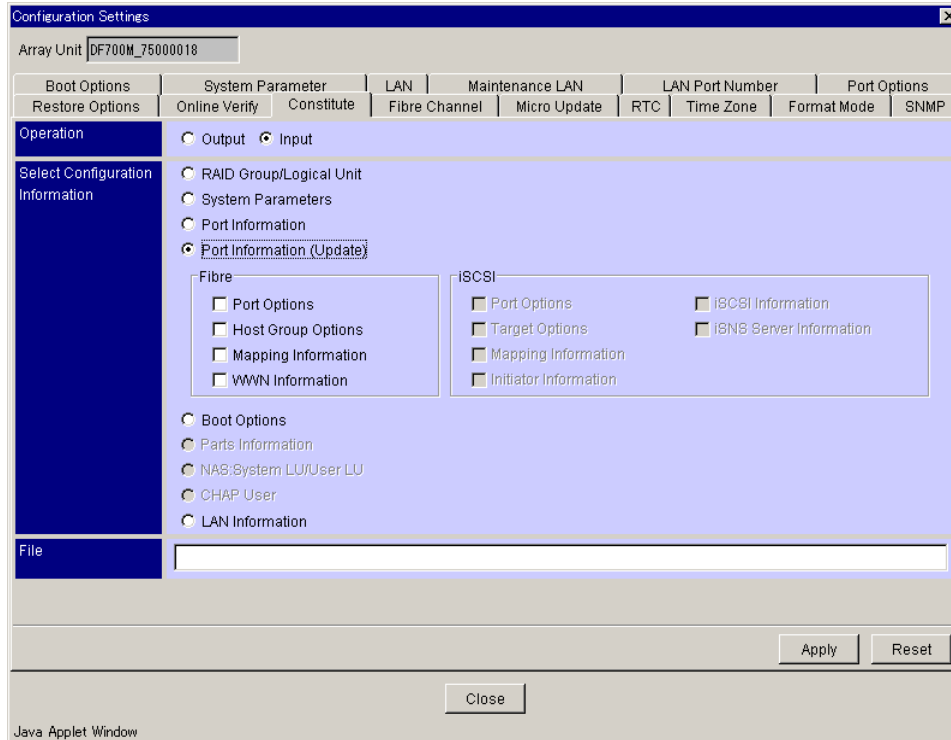

3. Click the **Port Information (Update)** option in the **Select Configuration Information** box.
4. Select the items that you will set from setting information for **Fibre**. An error will occur if nothing is chosen. (When the LUN Manager function is valid, the WWN Information displays for setting information for **Fibre**.)
5. Specify the directory and file name to which the host group information file will be input.
6. Select the **Input** option.
7. When the confirmation message displays, click **OK** to continue.
8. One or more messages advise that a subsystem restart is required. Follow the on-screen instructions to stop subsystem access and click **OK** to continue.
9. A message displays, stating that the setting is complete. Click **OK**.

File Output of Boot Option Information

1. On the **Tools** menu, select **Configuration Settings** or click .
2. Click the **Constitute** tab.

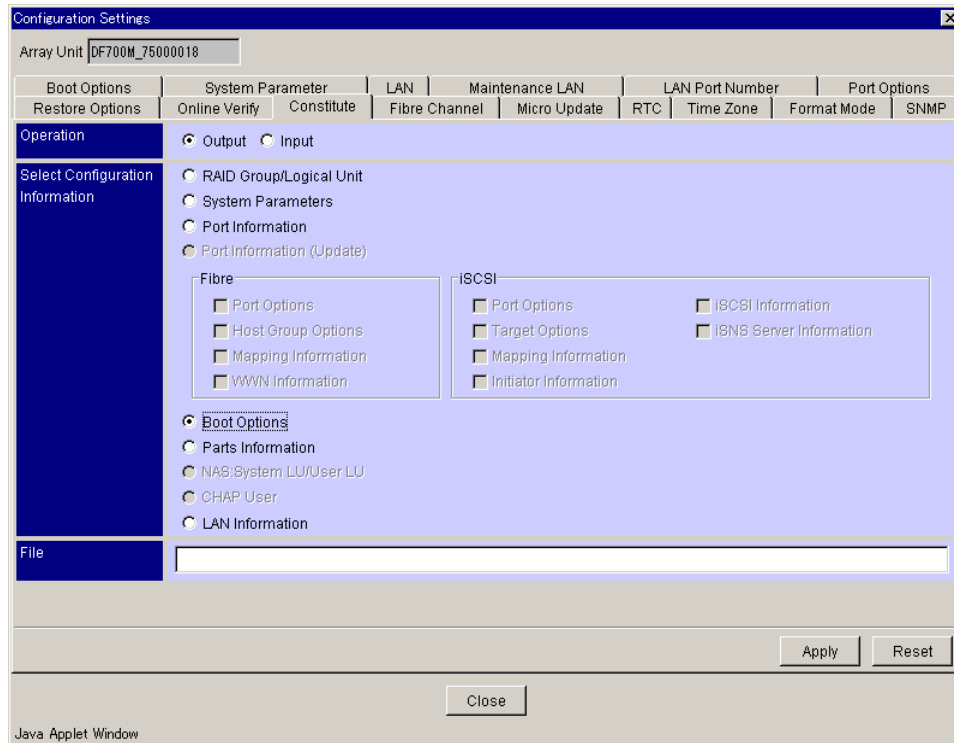

3. Check **Boot Options** in the **Select Configuration Information** box.
4. Specify the directory and file name to which the boot option information file will be output.
5. Click **Apply**.
6. When the confirmation message displays, click **OK**.

The boot options information is saved in the form of a text file with the specified file name.

The format of the output file consists of the following items. The outline of the layout of the output file is shown in following figure.

- File header
- Output time (Web Server time where Navigator 2 is installed)
- Firmware revision
- Subsystem type
- Serial number
- Boot options information

```

Boot Option list.
DF Name : DF700M_75000026
Date : 2007/11/30 15:39:25
Firmware Revision : 0720/A-M
Array Unit Type : DF700M
Serial Number : 75012345

---- Boot Options ----
System Startup Attribute = Dual Active Mode
Delay Planned Shutdown = 0
Options
  Drive Detach Mode = OFF
INQUIRY Information
Vendor ID =
Product ID =
ROM Microprogram Version =
RAM Microprogram Version =

```

Setting Boot Option Information with a File

WARNING: Rebooting requires stopping I/O from the host.

WARNING: If you are using TrueCopy or TrueCopy Extended Distance and you are required to reboot the subsystem, change the pair status to PSUS before you reboot.

WARNING: If you are using a NAS, you must also stop the clusters between NAS units. When restarting the subsystem, you must restart the clusters.

1. On the **Tools** menu, select **Configuration Settings** or click .
2. Click the **Constitute** tab.

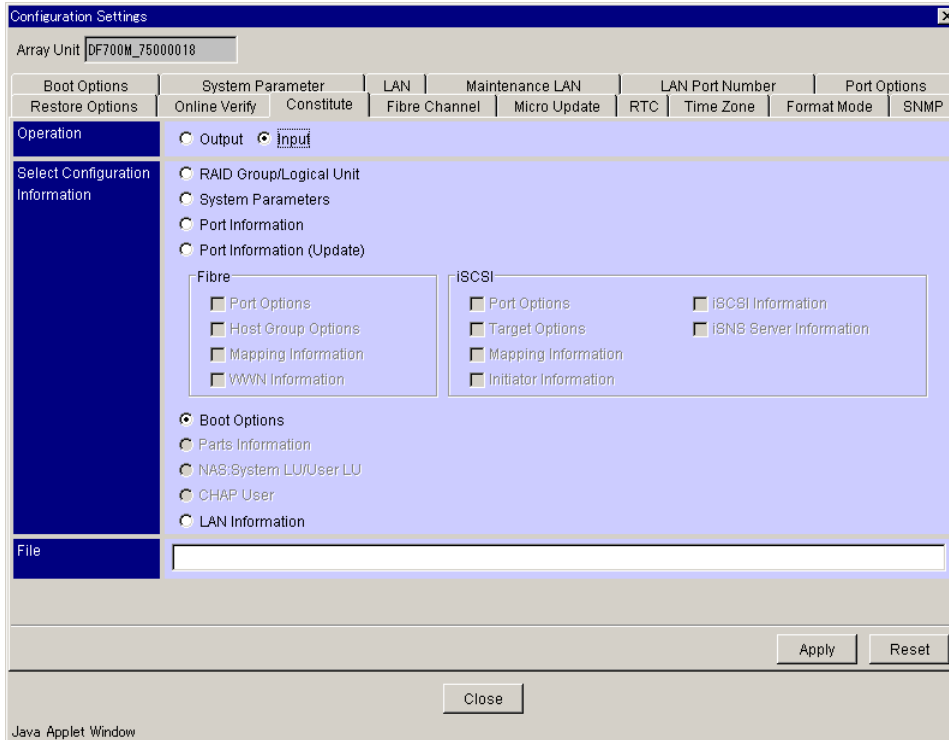

3. Check **Boot Options** and **Input** option in the **Select Configuration Information** box.

4. Specify the directory and file name to which the boot option information file will be input.
5. Click **Apply**.
6. When the confirmation message displays, click **OK**.
7. One or more messages advise that a subsystem restart is required. Follow the on-screen instructions to stop subsystem access and click **OK**.

When you choose to restart the subsystem, the time the restart began displays. This usually takes approximately 4 to 15 minutes.



Note: It may take time for the subsystem to respond, depending on the condition of the subsystem. If it does not respond after 15 minutes, check the condition of the subsystem.

8. A message displays, stating that the restart is successful.

File Output of Parts Information

To output parts information to a file:

1. On the **Tools** menu, select **Configuration Settings** or click .
2. Click the **Constitute** tab.

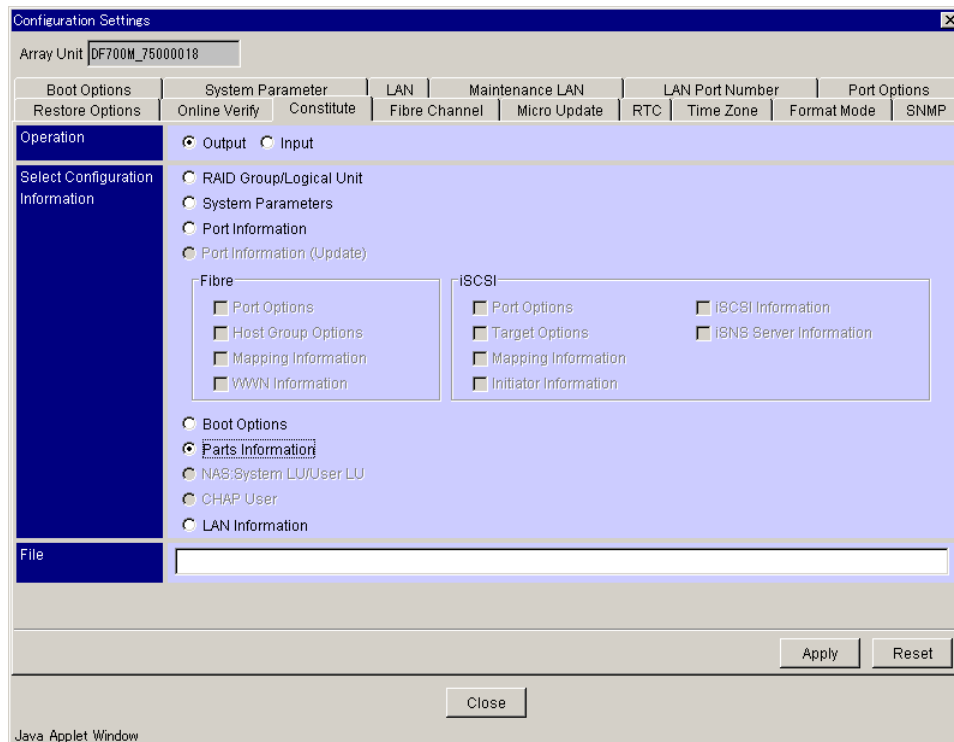

3. Check **Parts Information** in the **Select Configuration Information** box.

- Specify the directory and file name to which the parts information file will be output.
- Click **Apply**.
- When the confirmation message displays, click **OK**.

Outputting NAS System LU/User LU to a File

To output the NAS system LU/User LU to a file:

- On the **Tools** menu, select **Configuration Settings** or click .
- Click the **Constitute** tab.

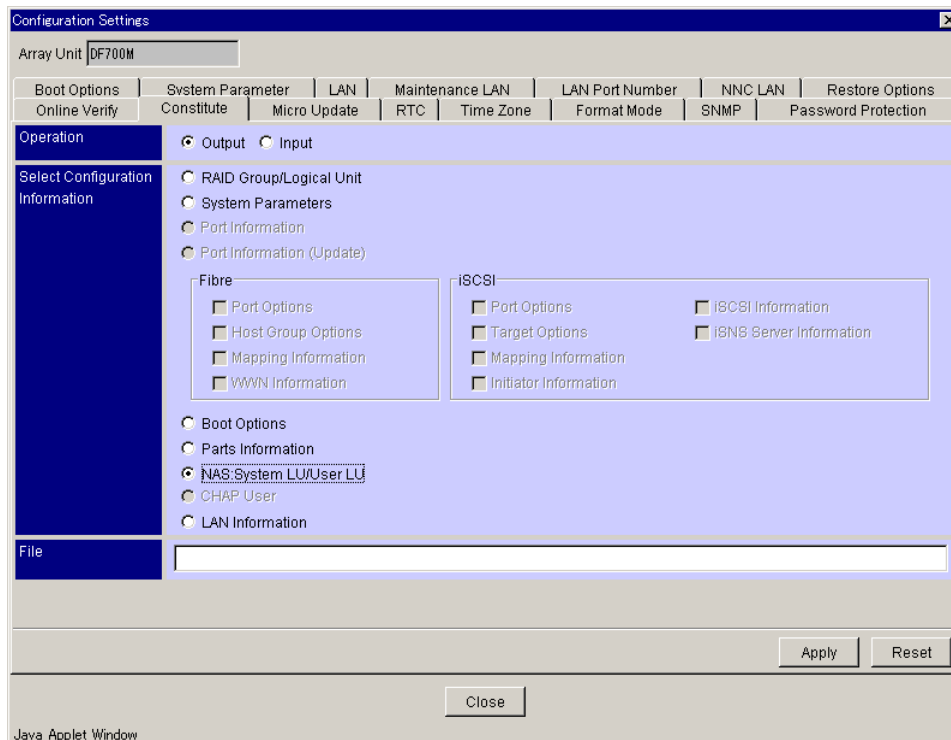

- Check the **NAS: System LU/User LU** option in the **Select Configuration Information** box.
- Specify the directory and file name to which the NAS system LU/User LU information file will be output.
- Click **Apply**.
- When the confirmation message displays, click **OK**.

The NAS System LU and NAS User LU information is saved in the form of a text file with the specified file name.

The format of the output file consists of the following items. The outline of the layout of the output file is shown in following figure.

- File header
- Registration name with Navigator 2 of the subsystem
- Output time (Web Server time where Navigator 2 is installed)
- Firmware revision
- Subsystem type
- Serial number
- NAS System LU information
- NAS User LU information

```

NAS LU mapping information list.
DF Name : DF700M_75000026
Date : 2007/11/30 15:52:13
Firmware Revision : 0720/A-M
Array Unit Type : DF700M
Serial Number : 75012345

---- NNC 0/2 Mapping Information ----
---- system LU Information ----
system LU                                LUN
system Disk(CTL0)                        0
system Disk(CTL1)                        1
volume for dump(CTL0)                   2
volume for dump(CTL1)                   3
Command Device                          4
working Area for Dump                    5
System Common volume                    6
Backup volume for Common                 7
Backup volume for Common 2              8

-- Separator
---- User LU Information ----
H-LUN      LUN
0          9
1         10
2         11

-- Separator
-- End

```

Setting NAS System LU/User LU Information with a File

1. On the **Tools** menu, select **Configuration Settings** or click .
2. Click the **Constitute** tab.
3. Check the **NAS:System LU/User LU** option and **Input** option in the **Select Configuration Information** box.
4. Specify the directory and file name to which the NAS system LU/User LU information file will be input.
5. Click **Apply**.
6. When the confirmation message displays, click **OK**.

File Output of iSCSI Port Information

To output the settings of the iSCSI port information for the subsystem in text form to a specified file:

1. On the **Tools** menu, select **Configuration Settings** or click .

2. Click the **Constitute** tab.

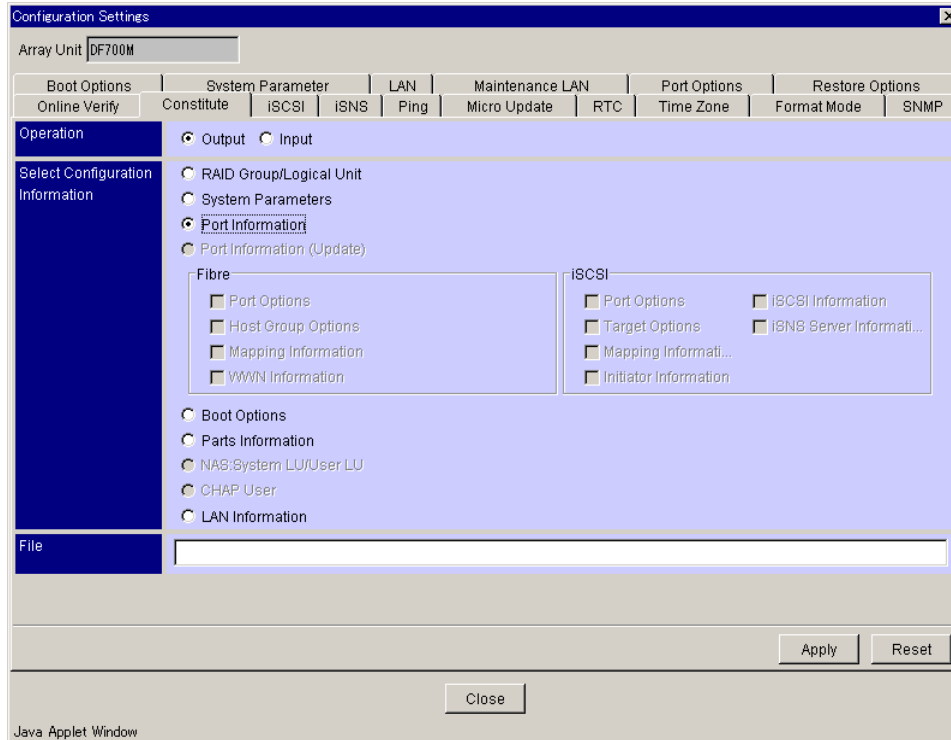

3. Check the **Port Information** option in the **Select Configuration Information** box.
4. Specify the directory and file name to which the iSCSI port information file will be output.
5. Click the **Output** option.
6. Click **Apply**.
7. When a message displays, confirming that the iSCSI port information is output with the specified file name, click **OK**.

The iSCSI port information is saved in the form of a text file with the specified file name.

The format of the output file consists of the following items. The outline of the layout of the output file is shown in following figure.

- File header
- Registration name with Navigator 2 of the subsystem
- Output time (Web Server time where Navigator 2 is installed)
- Firmware revision
- Subsystem type
- Serial number

- Mapping mode
- iSCSI port information
- Port options
- Target information
- Host system configuration
- Target options
- Logical unit mapping information

```

Configuration Information list.

DF Name : DF700M_75000026
Date : 2007/11/30 15:34:58
Firmware Revision : 0720/A-M
Array Unit Type : DF700M
Serial Number : 75012345

---- CommonInformation ----
MappingMode = ON

---- CTL0 ----
---- PortA ----
PortType = Fibre
---- PortOptions ----
Reset/LIP Mode(Signal) = OFF
Reset/LIP Mode(Process) = OFF
LIP Port All Reset Mode = OFF

---- HostGroupList ----
---- HostGroupInformation ----
HostGroupNumber = 0
HostGroupName = "G000"

---- HostSystemConfiguration ----
Platform = not specified
Alternate Path = not specified
Failover = not specified
Additional Parameters
None

---- HostGroupOptions ----
Host Connection Mode 1 = Standard Mode
Host Connection Mode 2
HP-UX Mode = OFF
PSUE Read Reject Mode = OFF
UA(06/2A00) suppress Mode = OFF
NACA Mode = OFF
HISUP OFF Mode = OFF
Reset Propagation Mode = OFF
Unique Reserve Mode 1 = OFF
ASL Report Mode(Active/Passive Group) = OFF
ASL Report Mode(Active/Passive) = OFF
ASL Report Mode(Active/Active) = OFF
Port-ID No Report Mode = OFF
Port-ID Conversion Mode = OFF
TRU Cluster Mode = OFF
Product Serial Response Mode = OFF
Same Node Name Mode = OFF
CCHS Mode = OFF
SPC-2 Mode = OFF

---- LUMapping ----
H-LUN LUN
-- HostGroupInformationEnd
-- HostGroupListEnd

--- LUNManagementInformation ---
Security = OFF
---- PermissionList ----
-- PermissionListEnd

```

Setting iSCSI Port Information with a File

To set iSCSI Port settings with a file:

1. On the **Tools** menu, select **Configuration Settings** or click .
2. Click the **Constitute** tab.

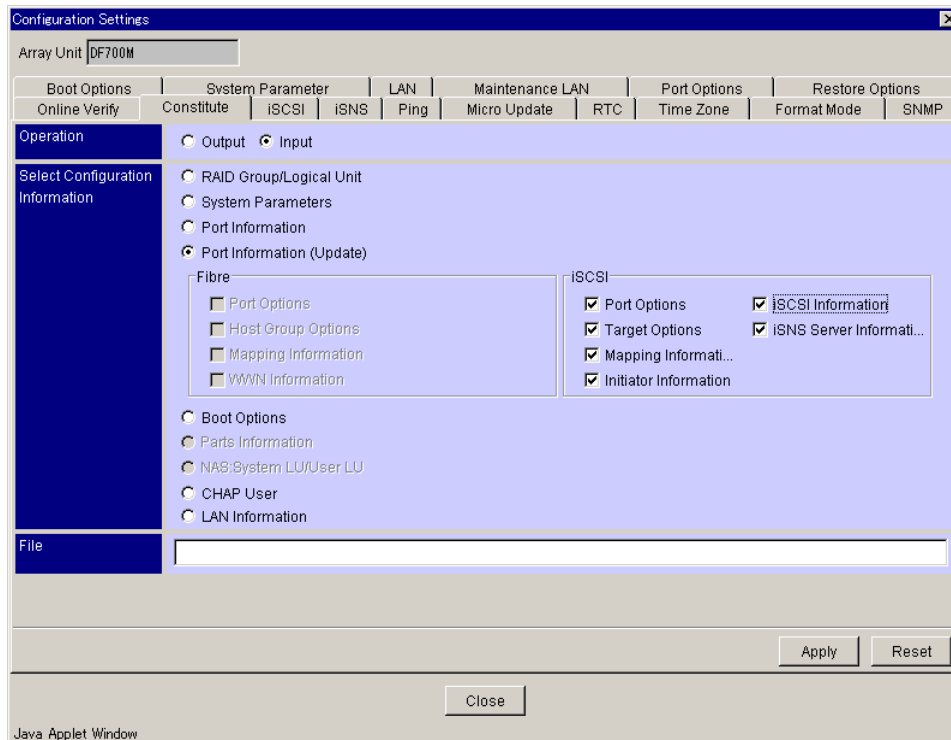

3. Click the **Port Information (Update)** option in the **Select Configuration Information** box.
4. Select the items that you will set from Setting Information for **iSCSI**. An error occurs if nothing is chosen. (When the LUN Manager function is valid, the Initiator Information displays for Setting Information for **iSCSI**.)
5. Specify the directory and file name to which the iSCSI port information file will be input.
6. Select the **Input** option.
7. A confirmation message displays. To continue, click **OK**.
8. One or more messages advise that a subsystem restart is required. Follow the on-screen instructions to stop subsystem access and click **OK** to continue.
9. A message displays, stating that the setting is complete. Click **OK**.

Setting CHAP User Information with a File

1. On the **Tools** menu, select **Configuration Settings** or click .
2. Click the **Constitute** tab.

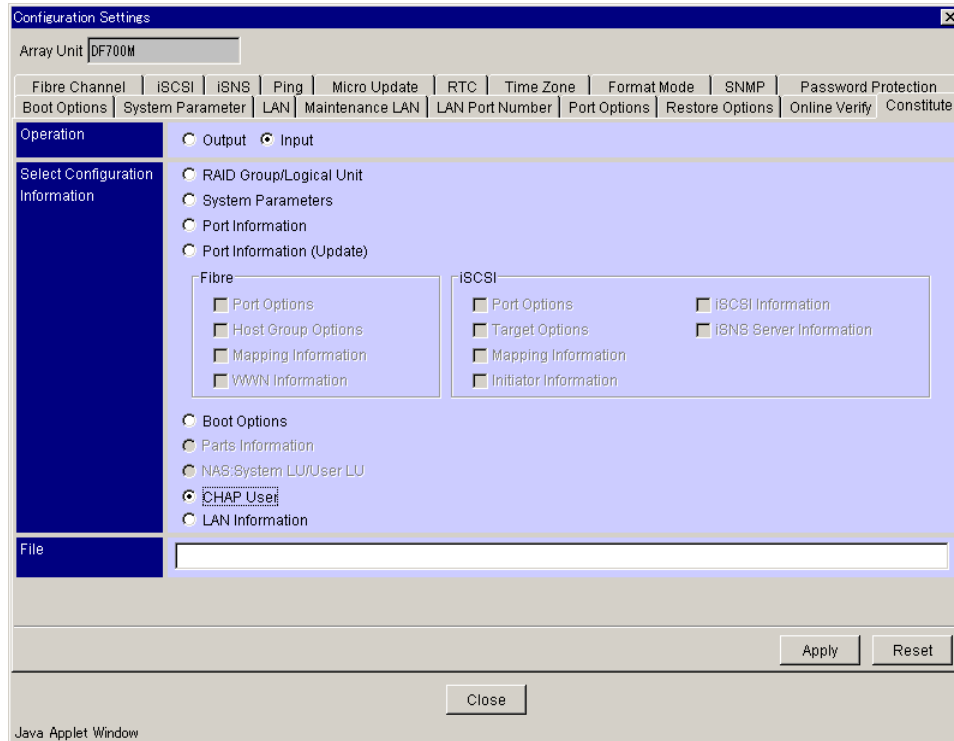

3. Click the **CHAP User** option in the **Select Configuration Information** box.
4. Specify the directory and file name to which the CHAP User information file will be input.
5. Select the **Input** option.
6. A confirmation message displays. To continue, click **OK**.

The CHAP User information setting file format is shown in Table 5.3.

Table 5.3 CHAP User Information Setting File Format

File Contents	Descriptions
User name,secret,Target No. or alias ...	The lines are invalid until <CHAP User> appears.
<CHAP User>,,	The valid lines are from <CHAP User> to <END>.
<Port 0A>,,	The line specifies the port. (<Port ALL> specifies all ports)
hitachi-0,abcdefghij00,alias0	The first column is CHAP User, and the second column is Secret.
hitachi-1,abcdefghij01,alias1	The third row and the following are aliases of Target to assign.
#hitachi-1,abcdefghij01,alias1	The line with the first character of # is a comment line. (Invalid line)
hitachi-2,abcdefghij02,3	The Target number can be specified as the alias of Target.
<Port 0B>,,	
<Add CHAP User>,,	If <Add CHAP User> is specified, CHAP User is added.
hitachi-0,abcdefghij00,alias0	If nothing is specified, all CHAP Users are deleted, and then added.
hitachi-1,abcdefghij01,alias0,alias01,alias02	One or more Targets can be specified.
<Port 1A>,,	
<Port 1B>,,	
<END>,,	The line of <END> and the following are all invalid lines.

File Output of LAN Information

To output the settings of the LAN information for the subsystem in text form to a specified file:

1. On the **Tools** menu, select **Configuration Settings** or click .
2. Click the **Constitute** tab.

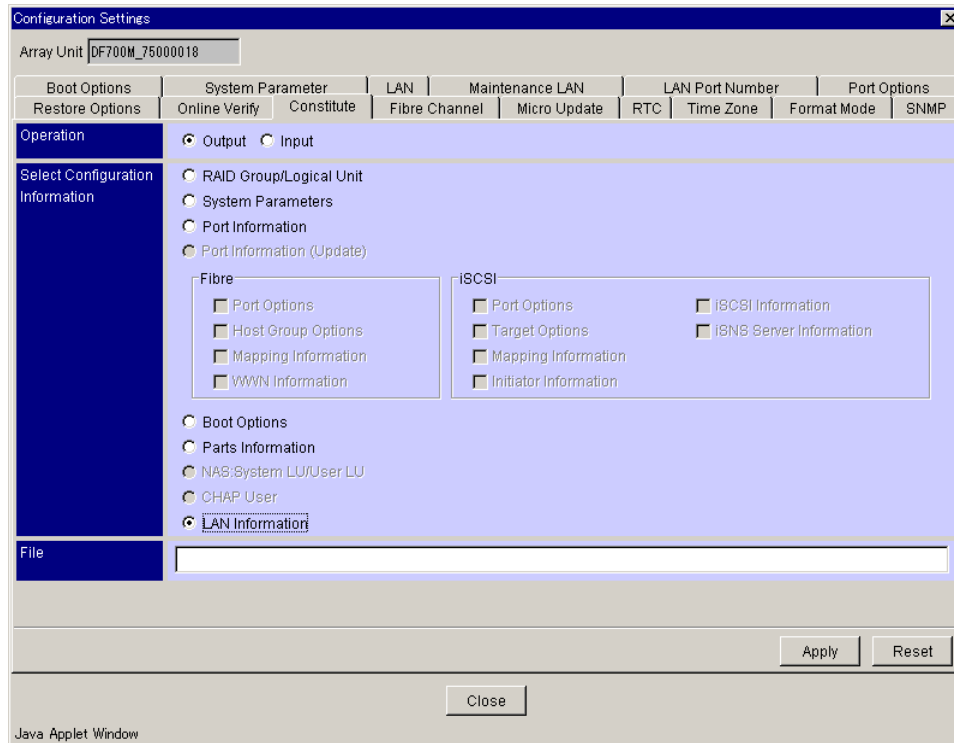

3. Check the **LAN Information** option in the **Select Configuration Information** box.
4. Specify the directory and file name to which the LAN information file will be output.
5. Click the **Output** option.
6. Click **Apply**.
7. When a message displays, confirming that the LAN information is output with the specified file name, click **OK**.

The LAN information is saved in the form of a text file with the specified file name.

The format of the output file consists of the following items. The outline of the layout of the output file is shown in following figure.

- File header
- Registration name with Navigator 2 of the subsystem
- Output time (Web Server time where Navigator 2 is installed)
- Firmware revision
- Subsystem type
- Serial number
- User LAN information

Maintenance Port IP Address Automatic Change Mode

- Maintenance Port LAN information

Concerning the Ether Address of the user LAN information, only the information on the controller connected over the LAN is output. To output the information on the both controllers, connect the both controllers over the LAN. When the information is output in the state in which the controller(s) is (are) blocked, the LAN information on the blocked controller(s) is output as 0.0.0.0.

```
LAN parameter list.
DF Name : DF700M_75000026
Date : 2007/11/30 15:48:08
Firmware Revision : 0720/A-M
Array Unit Type : DF700M
Serial Number : 75012345

---- User LAN Parameter ----
Maintenance Port IP Address Automatic Change Mode = OFF
---- CTL0 Parameter ----
DHCP = OFF
IP Address = 1.2.3.4
Subnet Mask = 11.12.13.14
Default Gateway = 21.22.23.24
Negotiation = 100Mbps/Full
Ether Address = 00:00:87:70:FF:1A
---- CTL1 Parameter ----
DHCP = ON
IP Address = 101.102.103.104
Subnet Mask = 111.112.113.114
Default Gateway = 121.122.123.124
Negotiation = 100Mbps/Half
Ether Address = --:--:--:--:--:--

---- Maintenance LAN Parameter ----
CTL0 IP Address = 10.0.0.16
CTL1 IP Address = 192.168.0.17
```

Setting LAN Information with a File

WARNING: The User LAN Parameter (Maintenance Port IP Address Automatic Change Mode, IP Address, Subnet Mask, Default Gateway) and Maintenance LAN Parameter (Network Address) can be set up. The other information cannot be set up.

To set LAN settings with a file:

1. On the **Tools** menu, select **Configuration Settings** or click .
2. Click the **Constitute** tab.

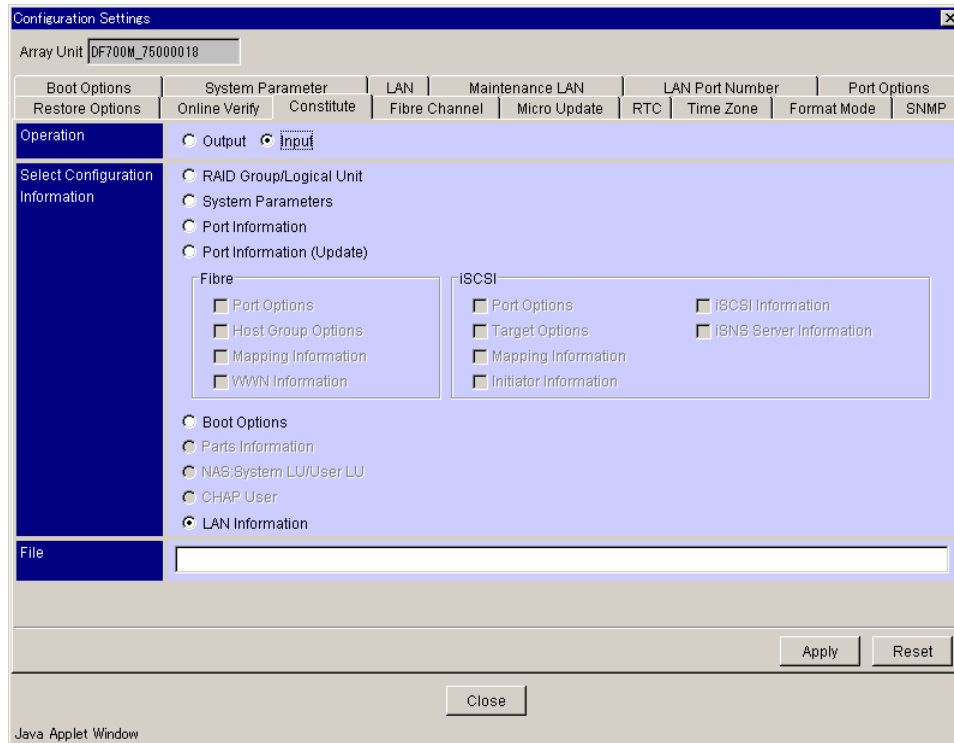

3. Click the **Input** option in the **Operation** box.
4. Check the **LAN Information** option in the **Select Configuration Information** box.
5. Specify the directory and file name to which the LAN information file will be input.
6. Click **Apply**.
7. A confirmation message displays. To continue, click **OK**.

Replacing a Firmware



Note: If a firmware is read during the firmware download, the download processing is interrupted. Read a firmware after checking that it is not under download.

The function downloads and replaces the firmware in the subsystem. When replacing the firmware, download it, and then replace it.

This section includes the following:

- Firmware Download
- Replacing the firmware

Firmware Download

Download the firmware from the CD-R into the subsystem. In the download, the firmware is stored in the subsystem; the firmware of the subsystem is not replaced.

1. Copy the firmware from the CD-R to the hard disk.



Note: For a directory where Navigator 2 is installed, do not copy the firmware directly to the CD-R. Create a subdirectory and copy it under this subdirectory. Specify the name of a directory in the hard disk drive to which the firmware is copied, with a one-byte coded alphanumeric.

2. On the **Tools** menu, select **Configuration Settings** or click .
3. Click the **Micro Update** tab.

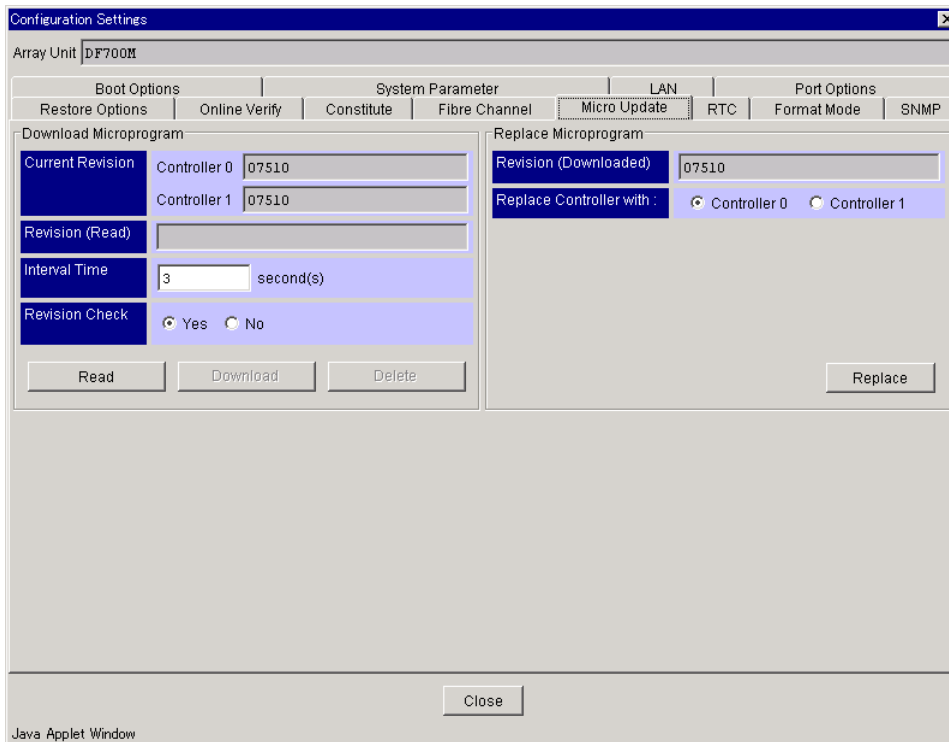

The screenshot shows the 'Configuration Settings' dialog box with the 'Micro Update' tab selected. The 'Array Unit' is 'DF700M'. The 'Download Microprogram' section includes fields for 'Current Revision' (Controller 0: 07510, Controller 1: 07510), 'Revision (Read)', 'Interval Time' (3 second(s)), and 'Revision Check' (Yes selected). The 'Replace Microprogram' section includes 'Revision (Downloaded)' (07510) and 'Replace Controller with' (Controller 0 selected). Buttons for 'Read', 'Download', 'Delete', and 'Replace' are present. A 'Close' button is at the bottom.

- **Current Revision:** Firmware revision of each controller of the subsystem.
- **New Revision:** A firmware revision stored in the system in which Navigator 2 is installed. When the firmware is not read, a blank is displayed.

- **Interval Time:** Interval time for download. Specify the time between 1 and 60 seconds. For the LAN connection, when the interval time is specified as 3 seconds, the download requires approximately 9 minutes. The time required for the execution varies with the network status and depends on I/Os issued by the host. When the interval time is specified as one second longer, the time required for the download is prolonged by 3 minutes.

This function can be used during execution of the I/O instructed by the host. However, when the download function is executed, I/O performance of the host is reduced. To enhance performance, specify a longer interval time.

- **Revision Check:** Instructs the revision check of the firmware to be downloaded. When the download instruction is specified, whether or not a hot replacement is applicable to the firmware is checked. Select **Yes**.

When no firmware is read, the **Download** and **Delete** buttons are displayed in gray and cannot be selected.

4. The firmware is read into the PC in which Navigator 2 is installed. Click **Read**. When a revision is displayed **Revision (Read)**, the firmware is already read. To download the firmware that is already read, execute Download.

When you have clicked **Read**, specify the revision directory in which the firmware is installed is specified, all the firmwares are read automatically.

5. When a confirmation message displays, asking whether to read the firmware, click **OK**.

If the firmware is already read, a confirmation message displays. When **OK** is clicked, the firmware is overwritten. To stop reading the firmware, click **Cancel**.

To delete the firmware that is already read in the Web Server, click **Delete**. When a confirmation message displays, click **OK**.

6. When a window for specifying a revision directory in which the read firmware exits displays, enter this directory. When **OK** is clicked, reading the firmware is started.

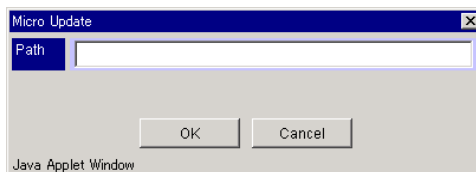

When using Windows®:

D:\DF700\program\micro_upload\firmware\0710A

Directory in the hard disk in which the firmware is copied.

7. When a message displays indicating that the firmware has been read, click **OK**.

The revision of the read firmware displays in the **Revision (Read)** field.

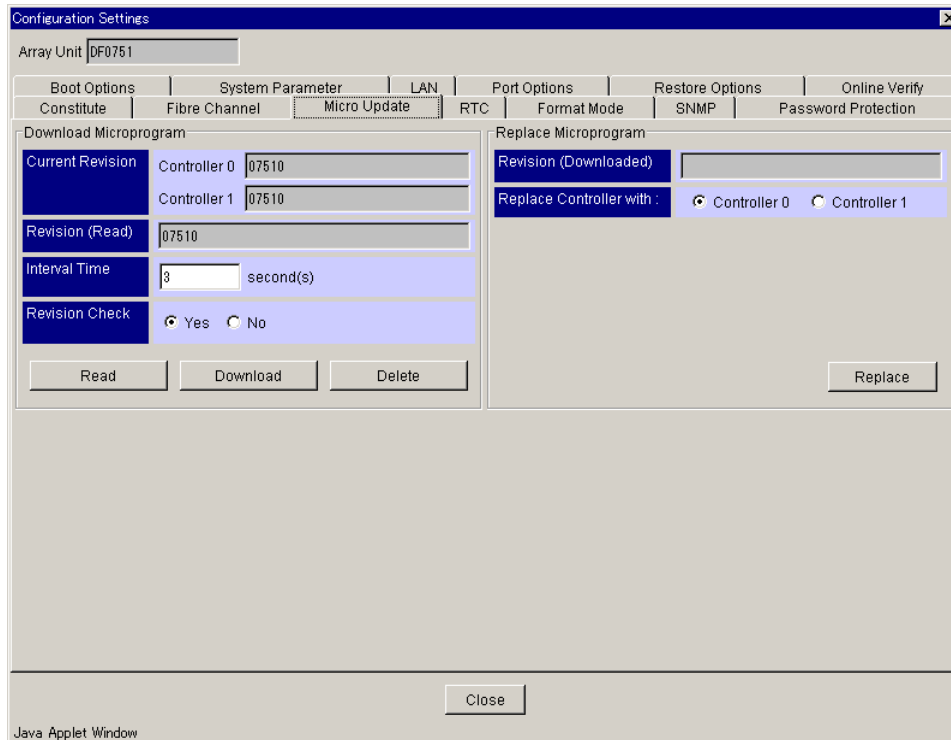

8. To download the firmware, click **Download**.
9. When a confirmation message displays requesting confirmation to download the firmware, click **OK**.
10. Select the access receptionist opportunity from the host after firmware replaced.

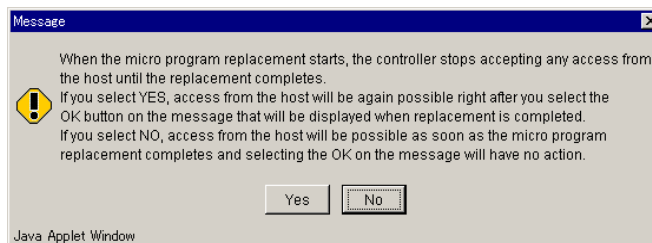

- If you click **Yes**, Navigator 2 will not receive access from the host until you click **OK**.
- If you click **No**, Navigator 2 receives access from the host.

A message displays stating that the download is being executed. This message displays the revision of the program being downloaded, interval time, and progress.

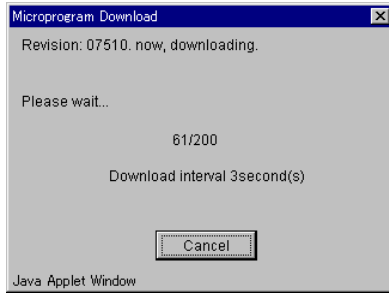

The download can be aborted. To abort the download halfway, click **Cancel**. A confirmation message displays. When **OK** is clicked, the download is aborted. When **Cancel** is clicked, the download is continued.

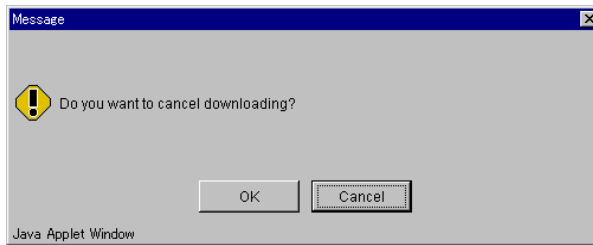

11. When the firmware is normally downloaded, a confirmation message displays. Click **OK**.



Note: After the firmware downloads, restart the subsystem or replace the firmware. If a hot replacement of the controller board is done before restarting the subsystem or the firmware replacement, the replaced new controller may be blocked. Download may terminate with a DMES05EA03 message when the subsystem is heavy host I/Os. Perform the download operation again.

Replacing a Firmware

Replace the firmware for the controller with the firmware downloaded in the subsystem. When replacing the firmware, replace both controller 0 and controller 1 firmwares. When connecting with both controllers or only with controller 0, replacement begins with controller 0 and then with controller 1. When connecting only with controller 1, replacement takes place in controller 1 and then controller 0.

Note: When only the controller of one side replaces firmwares and the Array Unit screen is closed, there is a case where the Array Unit screen stops opening after that. When the Array Unit screen does not open, replace the firmwares after replacing the firmwares into the registration of a controller that is not replacing firmwares.

WARNING: This operation will interrupt I/O from the host and may require rebooting the subsystem.

WARNING: If you are using TrueCopy or TrueCopy Extended Distance and you are required to reboot the subsystem, change the pair status to PSUS before you reboot.

WARNING: If you are using a NAS, you must also stop the clusters between NAS units. When restarting the subsystem, you must restart the clusters.

To replace the firmware:

1. On the **Tools** menu, select **Configuration Settings** or click .
2. Click the **Micro Update** tab.

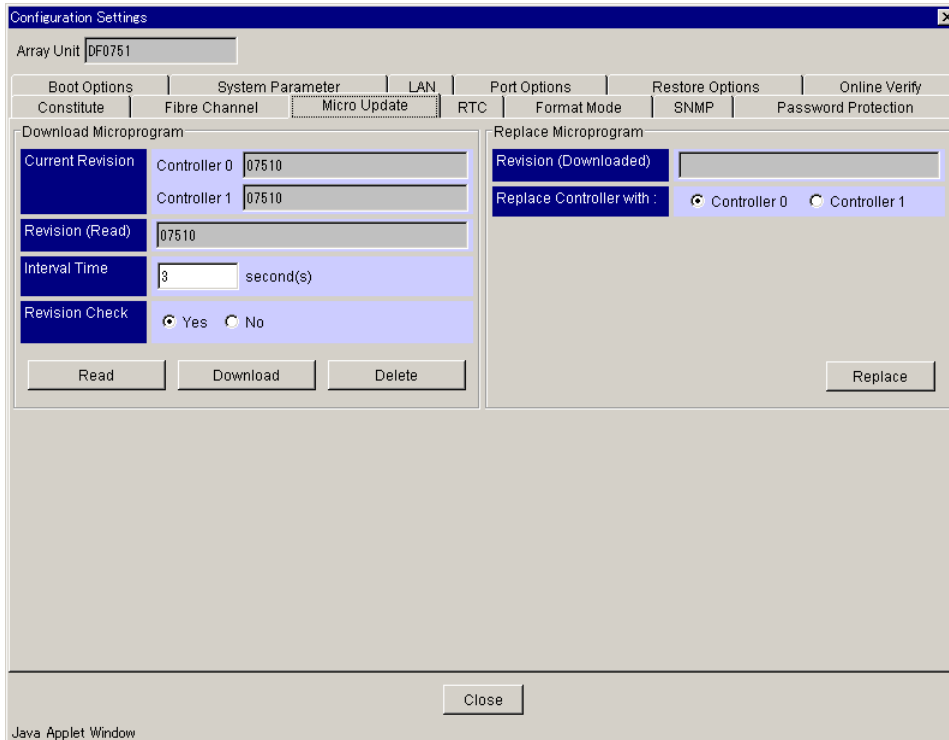

3. Select the controller whose firmware is to be replaced and click **Replace**.
4. A confirmation message displays. Click **OK**.

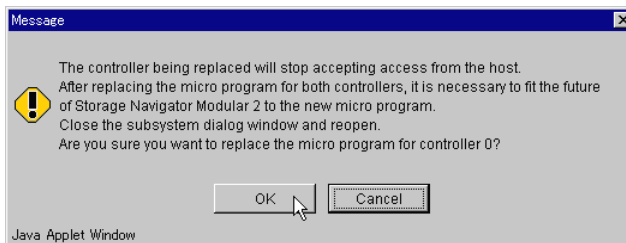

A status message displays.

5. After the firmware download, the following message displays. Check the contents of the message and click **OK**.

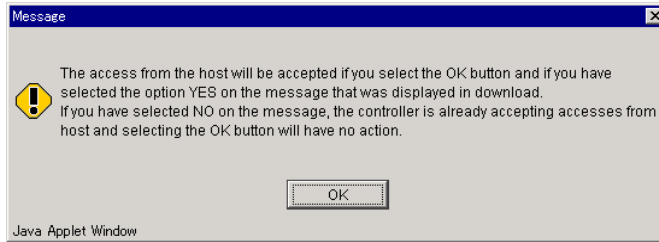

6. When the firmware replacement terminates normally, a completion message displays. When you click **OK**, the replacement firmware updates and a window displays.

If the downloaded firmware fails, a failure message displays. To validate the downloaded firmware, restart the subsystem.



Note: It may take time for the subsystem to respond, depending on the condition of the subsystem. If it does not respond after 15 minutes, check the condition of the subsystem.

7. Repeat this procedure to replace the firmware on the other controller. When replacements for both controllers terminate normally, the subsystem firmware replacement is complete.



Note: When a firmware is replaced, if the firmware for only one of the controllers is replaced, the subsystem declares a warning state. When the other controller's subsystem is replaced, the subsystem recovers from the warning state. Always replace the firmware for both controllers.

Setting the Backend Diagnosis Information

1. On the **Tools** menu, select **Configuration Settings** or click .
2. Click the **Backend Diagnosis** tab.

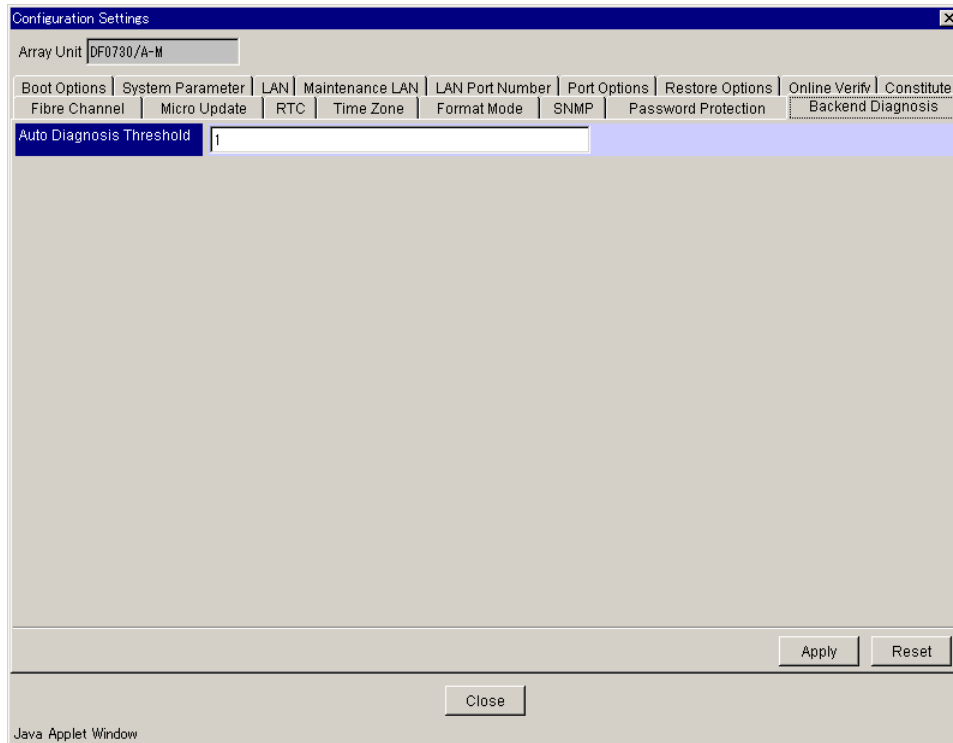

3. Click **Apply**.
4. A confirmation message displays. Click **OK**.

Configuring NNC

The following figure shows an example of a connection of the host computer (Web Server) in which Navigator 2 is installed and the subsystem to which the NNC option has been added.

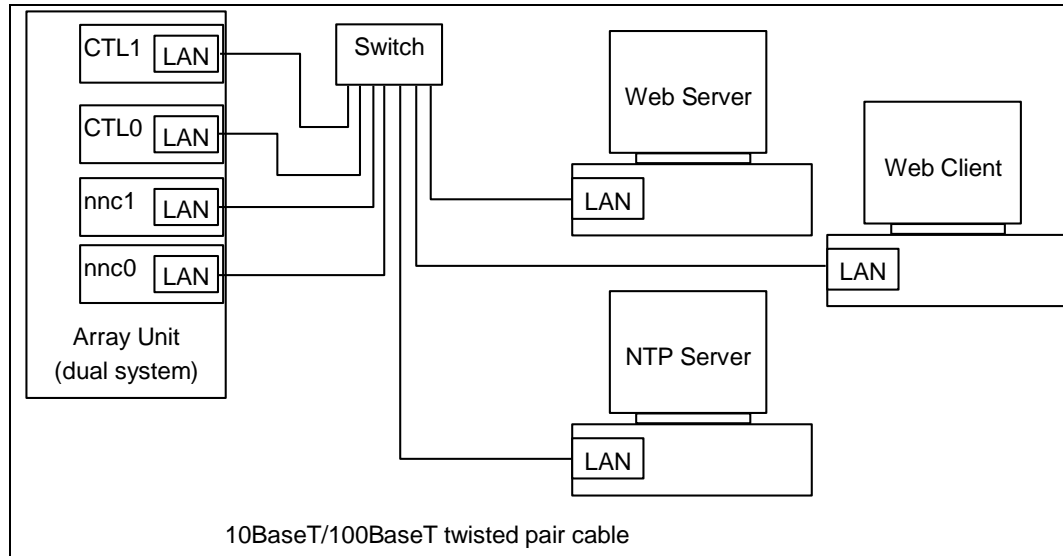

Setting NNC LAN Information

To set the NNC LAN information for management port:

1. On the **Tools** menu, select **Configuration Settings** or click .
2. Click the **NNC LAN** tab.

Configuration Settings

Array Unit: DF700M_75010031

Restore Options | Online Verify | Constitute | Micro Update | RTC | Time Zone | Format Mode | SNMP

Boot Options | System Parameter | LAN | Maintenance LAN | NNC LAN

NNC 0

Network	
	Setting
IP Address	199.60.13.2
Subnet Mask	255.255.255.0
MTU	2000
Negotiation	100Mbps/Full
Result	Normal

Current: IP Address 199.60.13.1, Subnet Mask 255.255.255.0, MTU 1500, Negotiation 100Mbps/Half, Result Normal

NNC 2

Network	
	Setting
IP Address	199.60.13.3
Subnet Mask	255.255.255.0
MTU	2500
Negotiation	100Mbps/Full
Result	Normal

Current: IP Address 199.60.13.2, Subnet Mask 255.255.255.0, MTU 3000, Negotiation 100Mbps/Half, Result Normal

Refresh Apply Reset

Close

Java Applet Window

- **Network:** Specify the **IP Address**, **Subnet Mask**, **MTU**, and **Negotiation**, which is part of the LAN information.

3. Click **Apply**.
4. When the confirmation message displays, click **OK**.

Setting NAS System Logical Units



Note: The NAS system logical units are usually set at the factory shipment, so that a user is not required to set them.

Nine logical units are required for the NAS system. The following figure shows the capacity that is necessary. When no logical unit is available for allocating to the NAS system logical unit, create it. See section 0 for information about creating a logical unit.

For NNC Type2

For NNC Type1

Name	LUN	Capacity	Name	LUN	Capacity
System Disk(CTL0)	0000	29.0GB	System Disk(CTL0)	0000	15.0GB
System Disk(CTL1)	0100	29.0GB	System Disk(CTL1)	0100	15.0GB
Volume for Dump(CTL0)	0001	6.0GB	Volume for Dump(CTL0)	0001	5.0GB
Volume for Dump(CTL1)	0101	6.0GB	Volume for Dump(CTL1)	0101	5.0GB
Command Device	0005	35.0MB	Command Device	0005	35.0MB
Command Device(Secondary)	0007	35.0MB	Working Area for Dump	0006	5.0GB
System Common Volume	0008	6.0GB	System Common Volume	0008	3.0GB
Backup Volume for Common	0009	6.0GB	Backup Volume for Common	0009	3.0GB
Backup Volume for Common 2	0010	6.0GB	Backup Volume for Common 2	0010	3.0GB

To set the NAS system logical units:

For NNC Type2

1. Click the **Logical Status** tab on the Array Unit screen.
2. Click the **NAS** plus sign.
3. Click the **NNC0/2** plus sign.
4. Click the **System** icon.

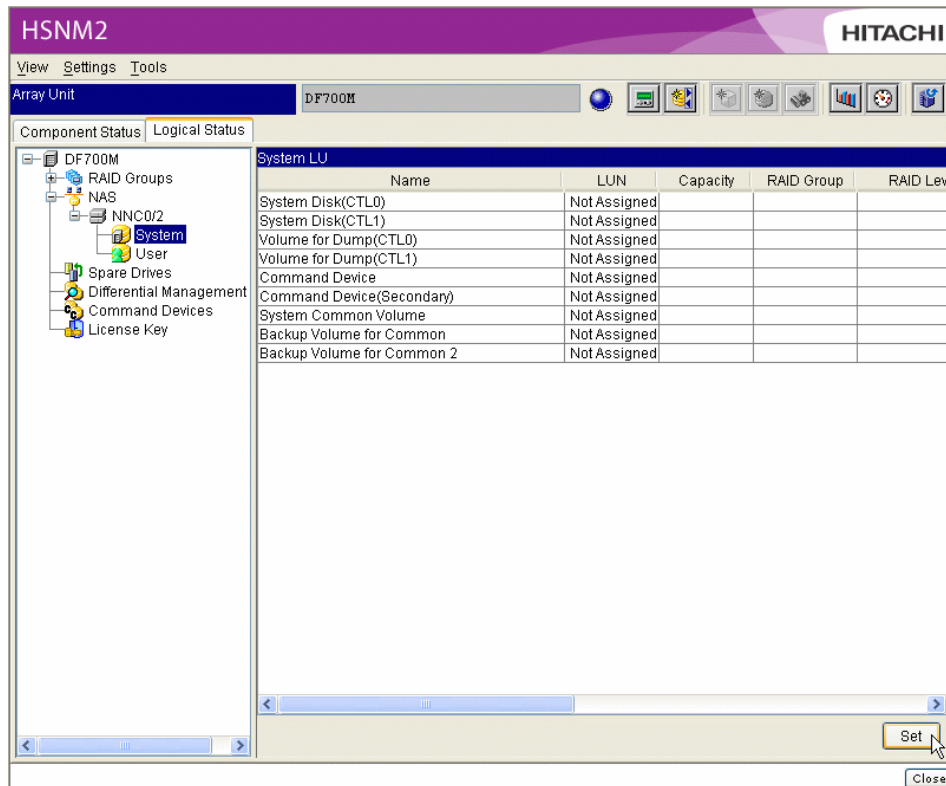

5. Click **Set**.
The **System LU** dialog displays.

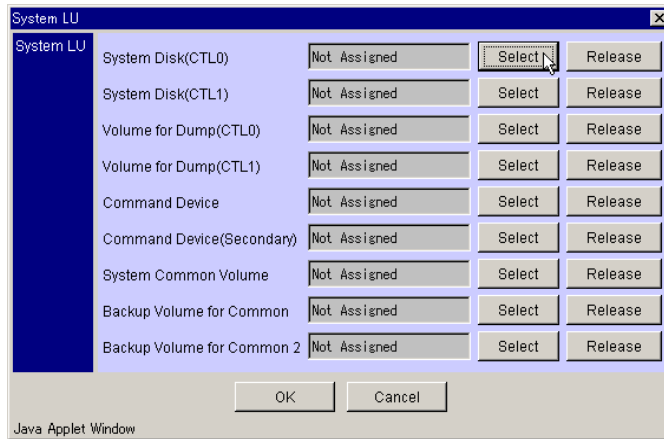

6. Click **Select** to set the System LU.

The **Select Logical Unit** dialog displays.

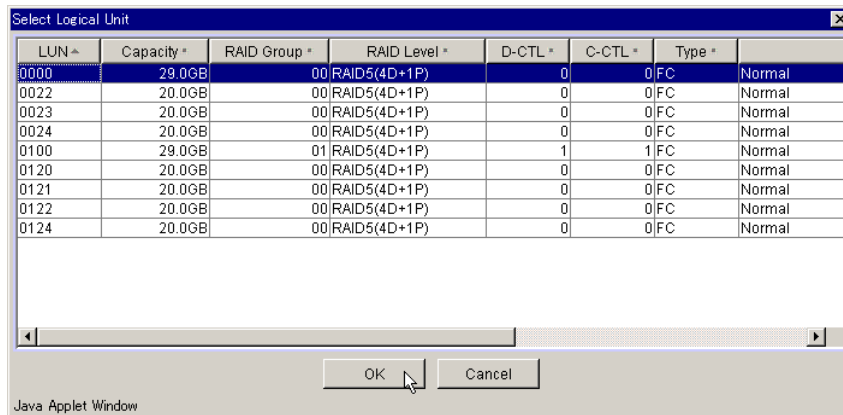

7. Select the **LUN** you want to set the System LU and click **OK**.

The selected LUN displays to the **System LU** dialog box.

8. Repeat steps 5 and 6 and complete a System LU list.

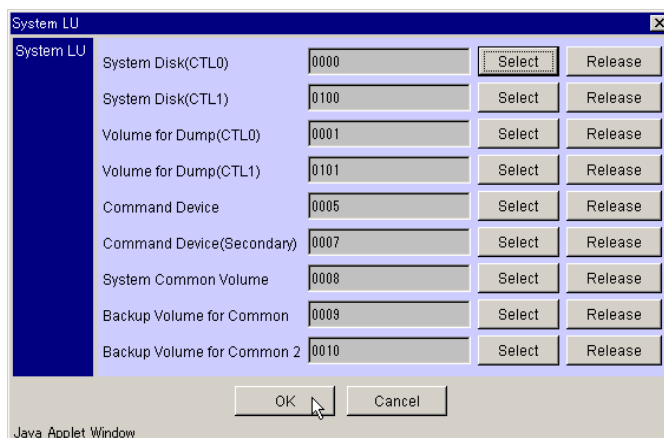

9. Click **OK**.

10. When the confirmation message displays, click **OK**.

For NNC Type1

1. Click the **Logical Status** tab on the Array Unit screen.
2. Click the **NAS** plus sign.
3. Click the **NNC0/2** plus sign.
4. Click the **System** icon.

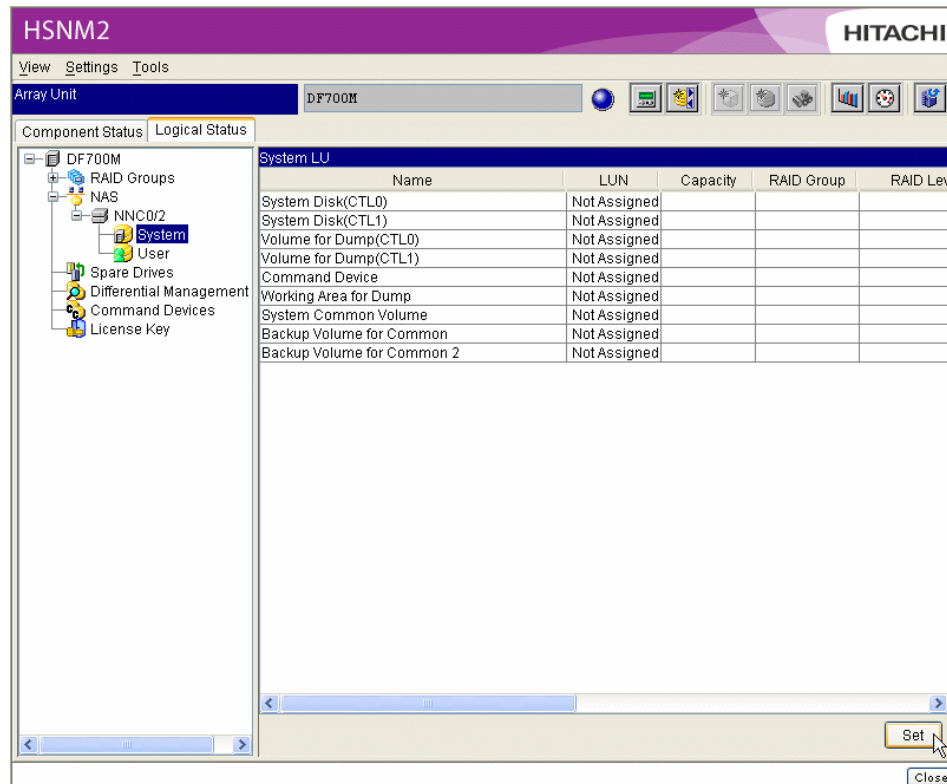

5. Click **Set**.

The **System LU** dialog displays.

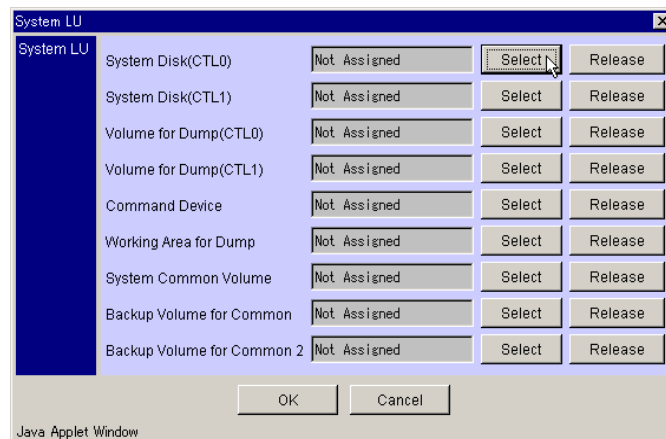

6. Click **Select** to set the System LU.

The **Select Logical Unit** dialog displays.

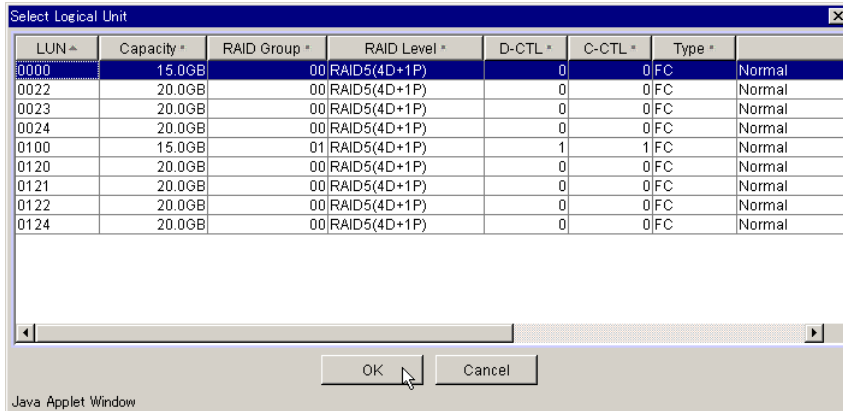

7. Select the **LUN** you want to set the System LU and click **OK**.
The selected LUN displays to the **System LU** dialog box.
8. Repeat steps 5 and 6 and complete a System LU list.

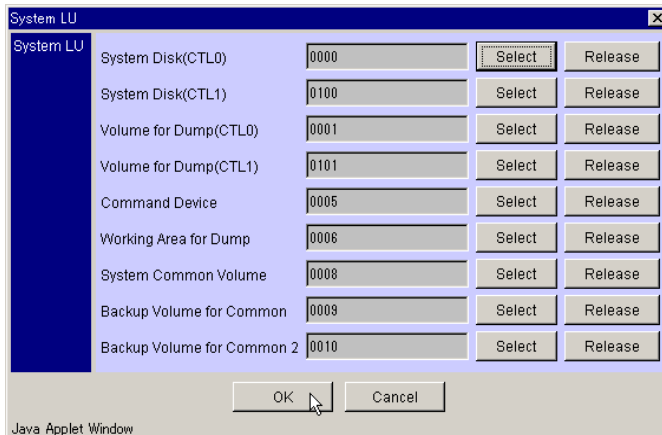

9. Click **OK**.
10. When the confirmation message displays, click **OK**.

Setting NAS User Logical Units

When no logical unit is available for allocating to the logical unit for the NAS user, create it. See section 0 for information about creating a logical unit.

To set the NAS user logical units:

1. Click the **Logical Status** tab on the Array Unit screen.
2. Click the **NAS** plus sign.
3. Click the **NNC0/2** plus sign.
4. Click the **User** icon.

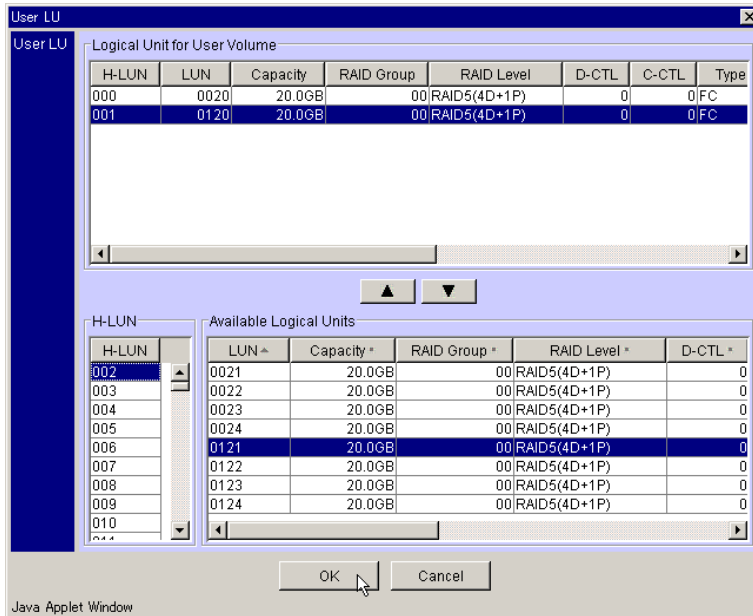

To cancel the assigned user LU, click the **H-LUN** to be canceled in the **Logical Unit for User Volume** list and click .

The selected **H-LUN** moves to the **Available Logical Units** list.

8. Click **OK**.
9. When the confirmation message displays, click **OK**.

Shutting Down/Booting/Rebooting NNC

Shutting Down the NNC



Note: When shutting down the NNC, just after the subsystem power ON or cluster start from the NAS Manager Modular, stop the NNC after the following confirmation displays:

The cluster status is "ACTIVE", and the resource group status is "Online" or "Offline".

When shutting down NCC and NNC is not in the above situation, it is possible that the cluster setting and resource group setting cannot execute normally. (Example: When executing the cluster stop from the NAS Manager that is connected to the NNC which is not executed the shutdown the NNC, it is possible that the cluster stop is not finished.) In this case, reboot the NNC, which is not executed the shutdown the NNC from Navigator 2.

1. Click the **Logical Status** tab on the Array Unit screen.
2. Select the **NAS** icon and then select the **NNC** number on the **NNC Status** list.

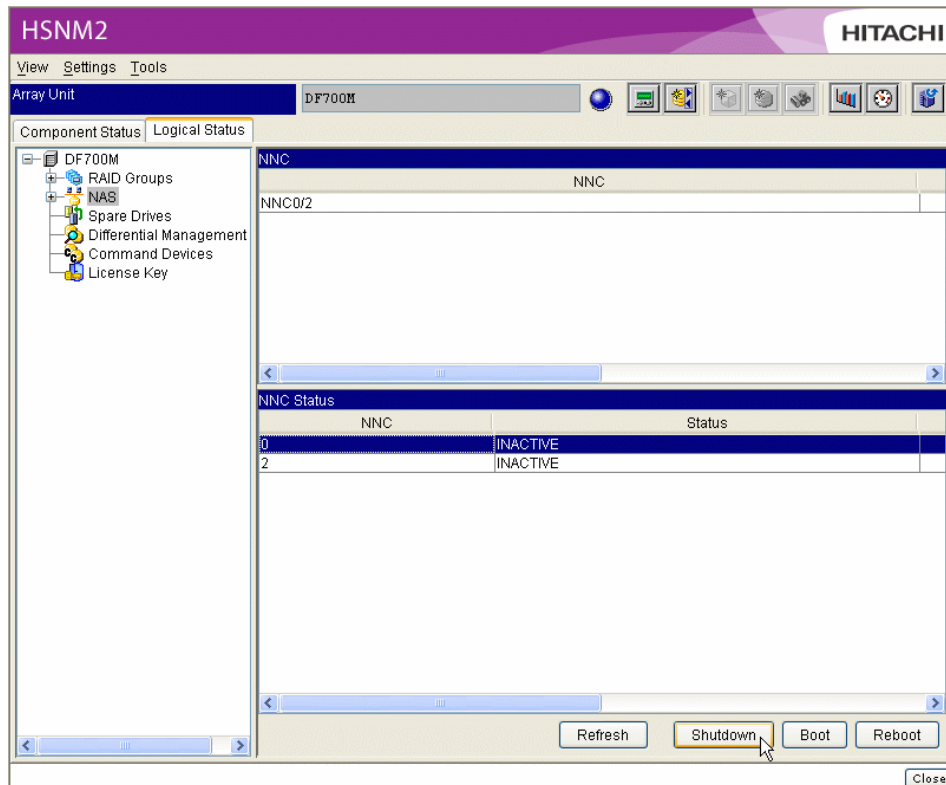

– **NNC Status:** Status of NAS OS:

ACTIVE: NAS OS is active and the Node is in operation.

BOOT: NAS OS is in boot process.

DISUSE: The controller is blocked.

DOWN: NAS OS is abnormally stopped.

DUMP: A NAS Dump is being collected.

HUNGUP: NAS OS is hung-up.

INACTIVE: NAS OS is in operation and the Node is stopped.

INST: NAS OS is in installation process.

NEW: NAS OS is not installed.

SHUTDOWN: NAS OS is in shutdown process.

STOP: NAS OS is normally stopped.

WARN: NAS Manager is not installed, or NAS OS is in operation and the status of the Node is unknown.

3. Click **Shutdown**.

4. When the confirmation message displays, click **OK**.

Booting the NNC



Note: There is not a difference in operation of boot and reboot. Do not specify anything for the boot option.

1. Click **Logical Status** on the Array Unit screen.
2. Select the **NAS** icon, and then select the **NNC** number on the **NNC Status** list.

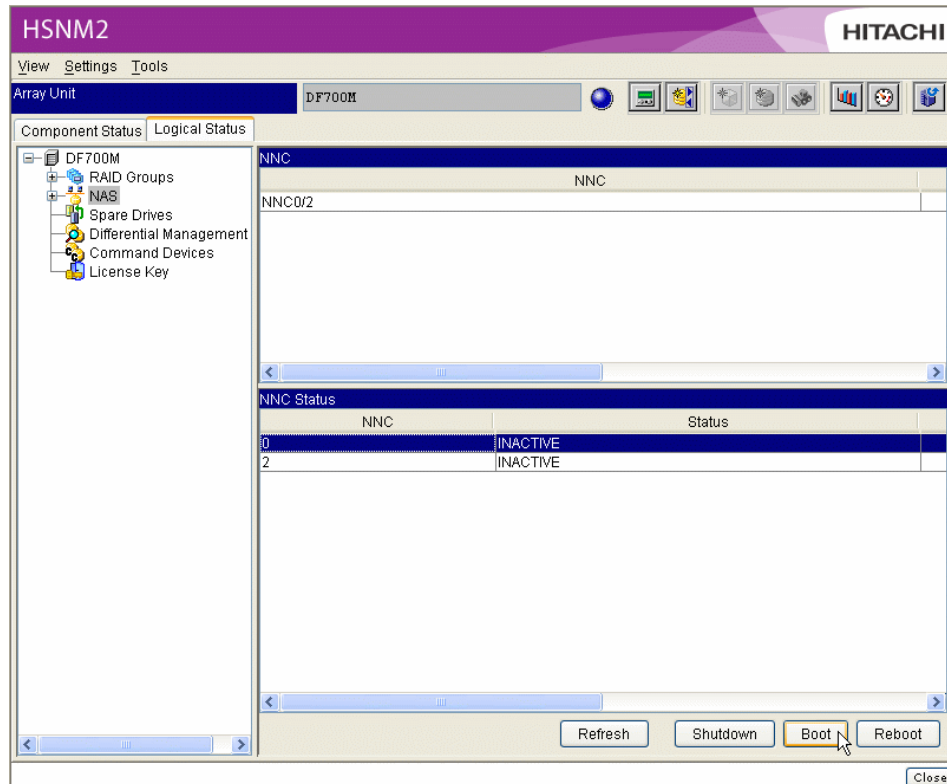

3. Click **Boot**.
4. When the confirmation message displays, click **OK**.

Rebooting the NNC



Note: When rebooting the NNC immediately after the subsystem power ON or cluster start from NAS Manager, reboot the NNC after the following confirmation displays.

- The cluster status is "ACTIVE", and the resource group status is "Online" or "Offline".

When rebooting the NNC and NCC is not in the above situation, it is possible that the cluster setting and resource group setting cannot execute normally.

(Example: When executing the cluster stop from the NAS Manager that is connected to NNC which is not executed the rebooting the NNC, it is possible that the cluster stop is not finished.) In this case, reboot the NNC which is not executed the rebooting the NNC from Navigator 2.

1. Click **Logical Status** on the Array Unit screen.
2. Select the **NAS** icon, and then select the **NNC** number on the **NNC Status** list.

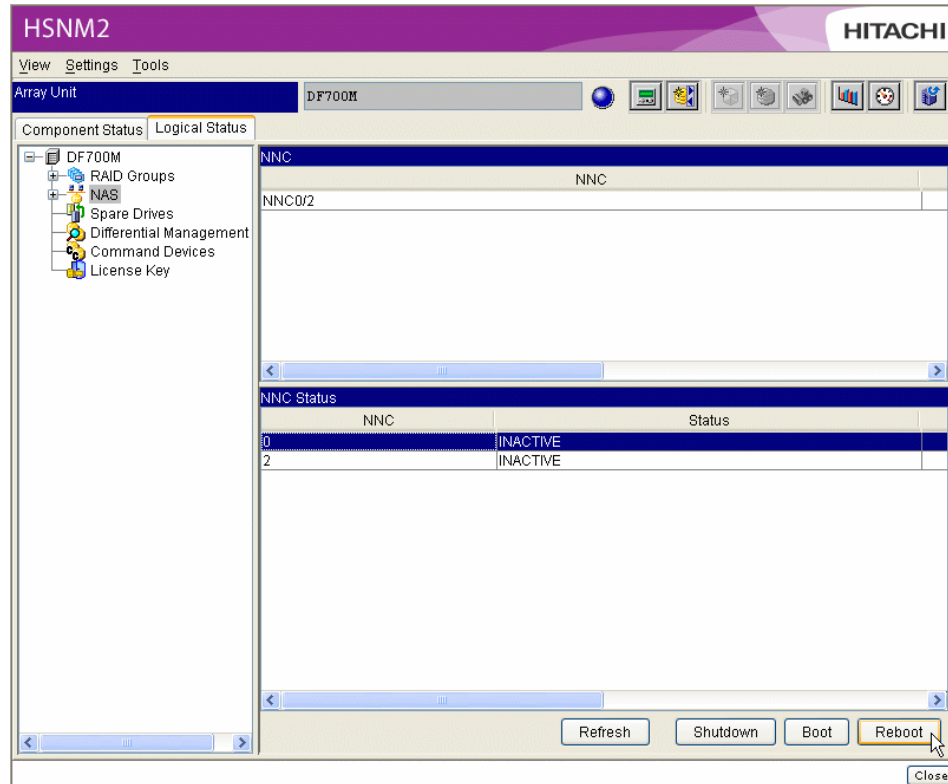

3. Click **Reboot**.
4. When the confirmation message displays click **OK**.

Displaying Statistical Information

Displaying Controller Activity

To display controller activity:

1. On the **Tools** menu, select **Statistical Information** or click .

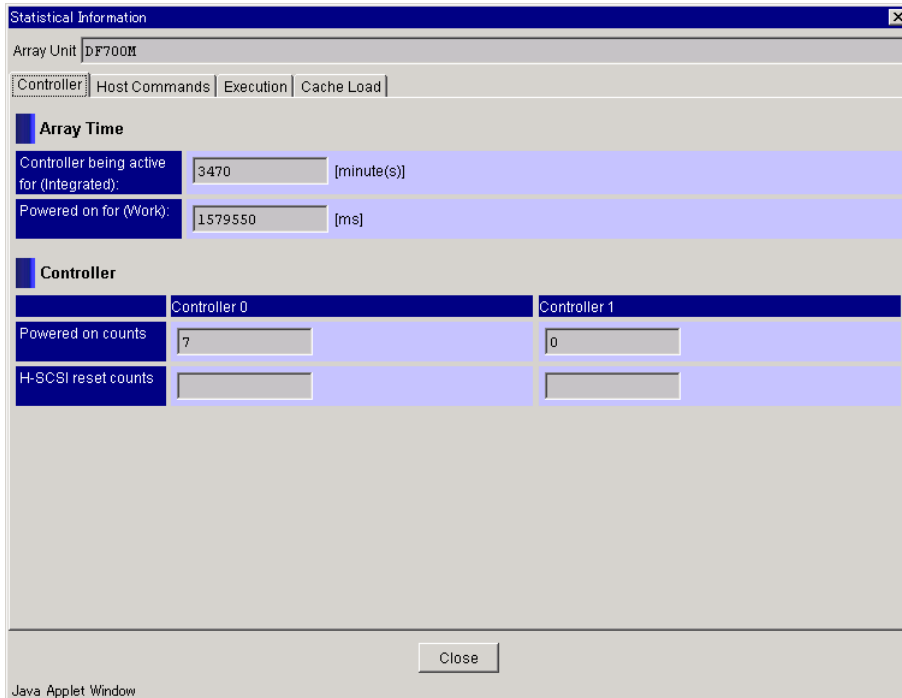

Array Time

- **Controller being active for (Integrated):** The accumulated time when the power is applied from the initial powering on of the subsystem to the latest powering off is displayed by the minute.
- **Power on for (Work):** The time elapsed from the powering on of the subsystem to the present time is displayed by the millisecond.

Controller

- **Powered on counts:** Integrated number of power ON times (at interruption) of the controller.
- **H-SCSI reset counts:** Integrated number of host bus SCSI reset times (total of interruptions and messages) of the controller (not supported).

Displaying Host Commands Received (Read/Writes per LU)

To display the cumulative read and write commands per logical unit, select the **Host Commands** tab.

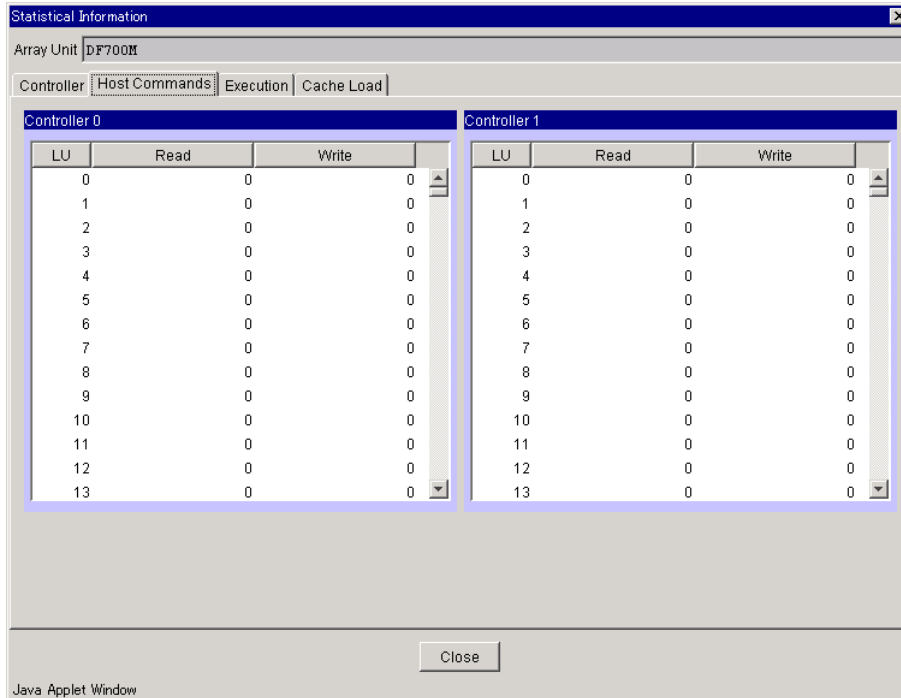

The screenshot shows a 'Statistical Information' window for Array Unit DF700M. It has three tabs: 'Host Commands', 'Execution', and 'Cache Load'. The 'Host Commands' tab is active, displaying two tables for Controller 0 and Controller 1. Each table has columns for LU, Read, and Write. All values are 0.

Controller 0				Controller 1			
LU	Read	Write		LU	Read	Write	
0	0	0	0	0	0	0	0
1	0	0	0	1	0	0	0
2	0	0	0	2	0	0	0
3	0	0	0	3	0	0	0
4	0	0	0	4	0	0	0
5	0	0	0	5	0	0	0
6	0	0	0	6	0	0	0
7	0	0	0	7	0	0	0
8	0	0	0	8	0	0	0
9	0	0	0	9	0	0	0
10	0	0	0	10	0	0	0
11	0	0	0	11	0	0	0
12	0	0	0	12	0	0	0
13	0	0	0	13	0	0	0

- **LU:** Logical unit number
- **Read:** Accumulated number of received read commands in each logical unit
- **Write:** Accumulated number of received write commands in each logical unit

Displaying Command Execution Activity

To display the command execution activity, select the **Execution** tab.

Statistical Information

Array Unit: DF700M

Controller | Host Commands | Execution | Cache Load

Controller 0					Controller 1				
Title					Title				
A : Logical Unit					A : Logical Unit				
B : Read Cache Hits					B : Read Cache Hits				
C : Write Cache Hits					C : Write Cache Hits				
D : Sequential Read					D : Sequential Read				
E : Sequential Write					E : Sequential Write				
F : Prefetch Stagings					F : Prefetch Stagings				
G : Write Through Operation					G : Write Through Operation				
A	B	C	D	E	A	B	C	D	E
0	0	0	0	0	0	0	0	0	0
1	0	0	0	0	1	0	0	0	0
2	0	0	0	0	2	0	0	0	0
3	0	0	0	0	3	0	0	0	0
4	0	0	0	0	4	0	0	0	0
5	0	0	0	0	5	0	0	0	0
6	0	0	0	0	6	0	0	0	0
7	0	0	0	0	7	0	0	0	0
8	0	0	0	0	8	0	0	0	0
9	0	0	0	0	9	0	0	0	0
10	0	0	0	0	10	0	0	0	0

Close

Java Applet Window

- **A: Logical Unit:** Logical unit number
- **B: Read Cache Hits:** Total of READ commands (hitting cache or partially hitting cache)
- **C: Write Cache Hits:** Total of WRITE commands (cache read hits)
- **D: Sequential Read:** Total of READ commands (recognized as sequential reading)
- **E: Sequential Write:** Total of WRITE commands (recognized as sequential writing)
- **F: Prefetch Staging:** Total of pre-fetch jobs executed
- **G: Write Through Operation:** Total of WRITE or WRITE & VERIFY commands (substituted by Write-Through operations)
- **H: Reassigned Blocks:** Number of re-assigned blocks (not supported)

Displaying Cache Load Condition

To display cache load activity, click the **Cache Load** tab.

Number of Inflow Threshold Reached	Cache Partition	CTL0	CTL1
0		0	0
1		0	0

- **Number of Inflow Threshold Reached:** Total number of occurrences of inflow limitations.

This equipment manages the amount of data in cache as an inflow limit. When the host tries to write data exceeding this limit, an inflow limitation occurs. In this case, the write request from the host waits until part of the write data is transferred to the drive.

Acquiring Performance Information

In the statistics information, the command operation state is output for each logical unit in the array unit. The command operation state consists of three types of data: the number of received commands, the number of cache-hit commands, and the cache hit rate for each Read or Write command.

Collecting Performance Statistics

To collect performance statistics:

1. On the **Tools** menu, select **Performance → Settings**.

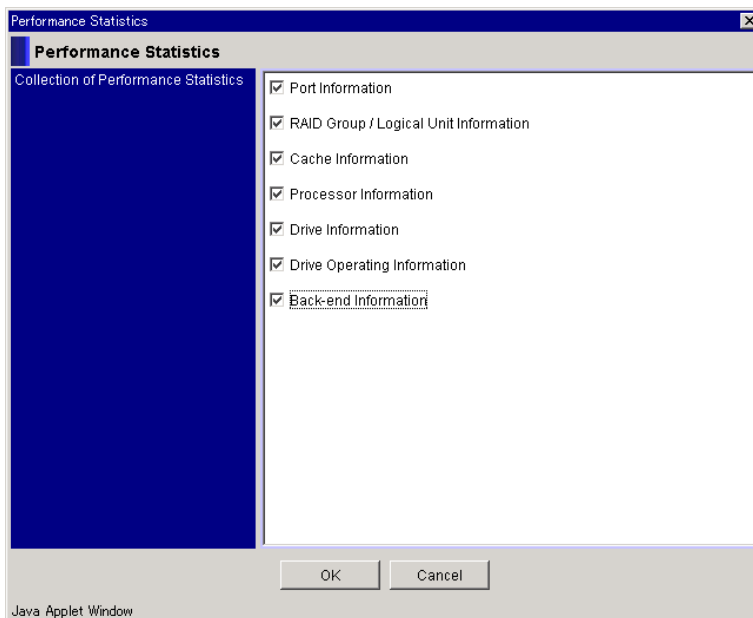

2. Select items from the **Collection of Performance Statistics**.
3. Click **OK**.
4. A confirmation message indicates that the host access may be affected during statistic collection. Click **OK**.

Manually Outputting Performance Statistics to a Text File

To create a performance-statistic text file:

1. On the **Tools** menu, select **Performance → Output File** or click .

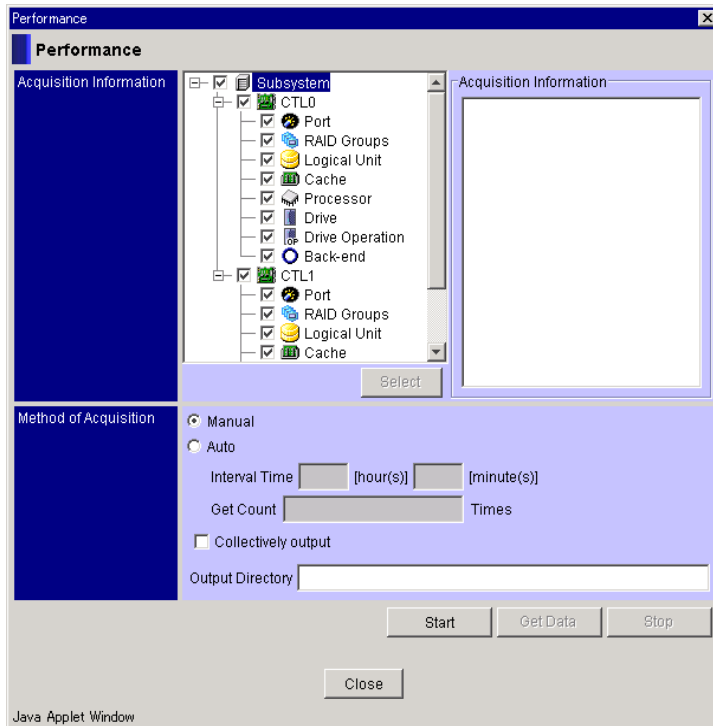

2. Select a component name (**Port, RAID Groups, Logical Unit, Cache, Processor, Drive, Drive Operation, or Back-end**) for information about the controller.
3. Specify the extent of the output using **Select**, excluding the **Cache** and **Processor**. When the extent is not specified, all is output. For example, when you want to specify an extent of information on the **Logical Unit**, select the **Logical Unit** icon, click **Select**, and specify the extent of the **Logical Unit**.

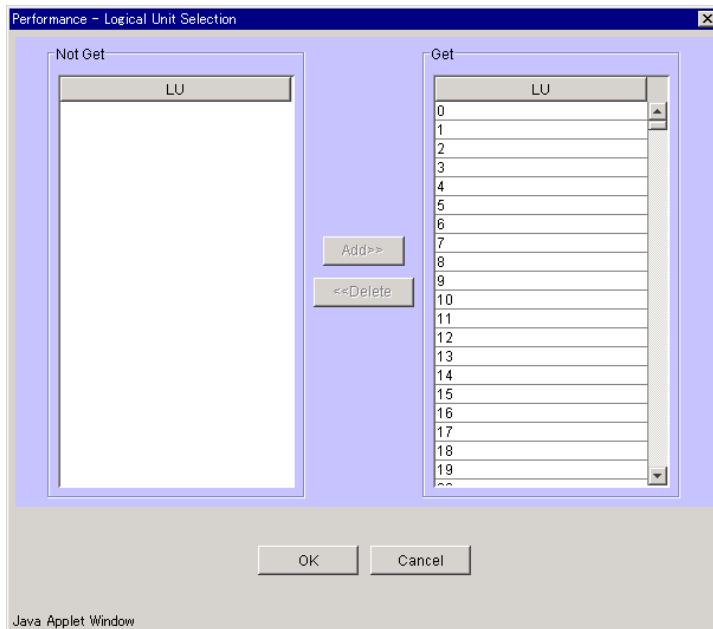

4. Click the number of the first LU you do not want to output. Scroll the LU numbers with the slider keeping the **Shift** key pressed, and click the number of the last LU.

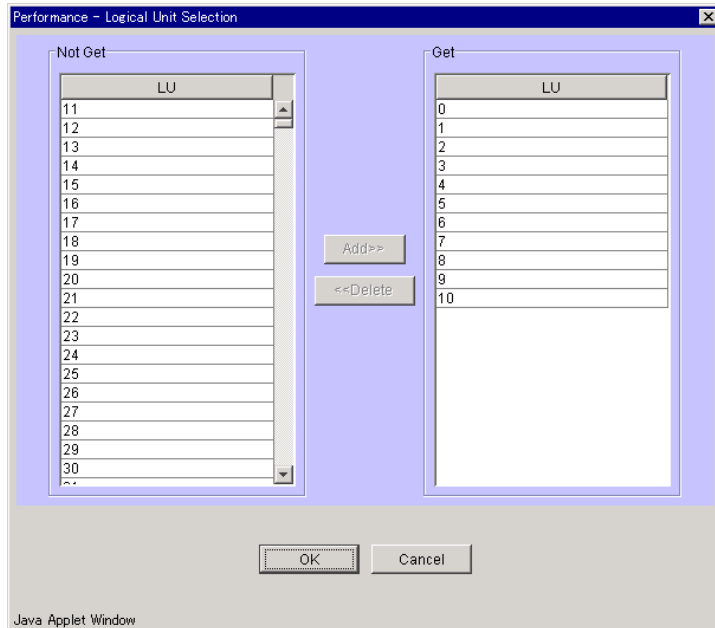

5. Click **OK**.
6. Select the **Manual** option.
7. Set the **Collectively output** option:
 - Select to append the current output to the previous output.
 - Clear to collect only the current output.
8. Specify the output directory. If the output directory is omitted, output defaults to the directory Navigator 2 installation directory.
9. Click **Start**.
10. Click **Get Data**.

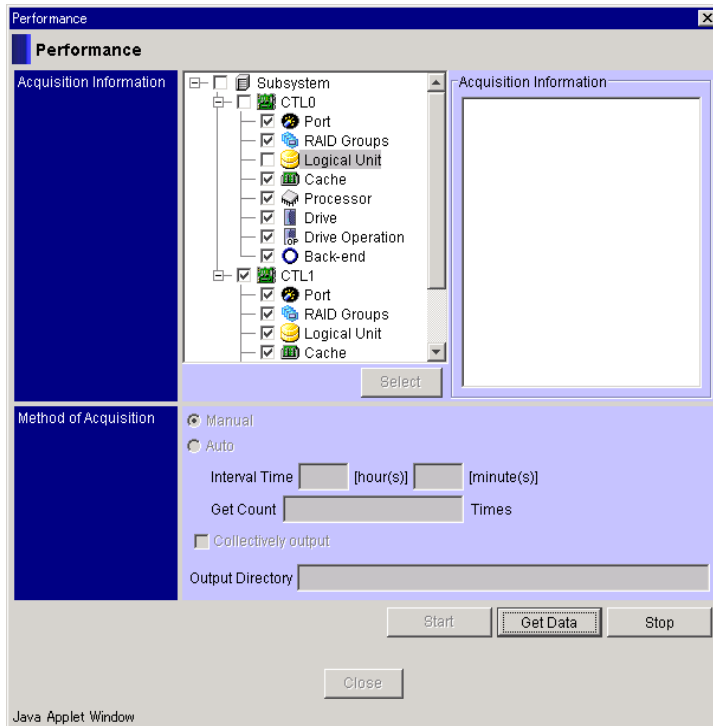

- a) When the **Collectively output** is not specified:
 These files are output in the text file format.
 : pfm\$\$\$\$\$.txt (\$\$\$\$\$: serial number from 00000 to 19999)



Note: Files are output with the names of pfm00000.txt to pfm19999.txt. After pfm19999.txt, pfm00000.txt is overwritten. Transfer the necessary information to another directory.

The information is acquired according to the following timing.

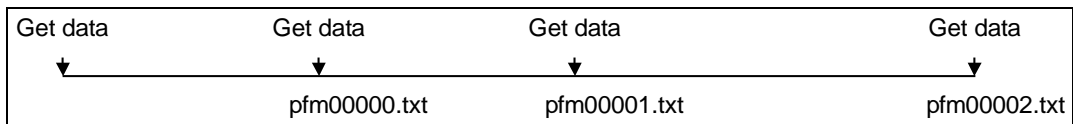

- b) When the **Collectively output** is specified:
 This file is output in the text file format (pfm.txt).

11. After the file processed is terminated, a confirmation message displays. Click **OK**.

12. Click **Stop**.

When the single system is connected, information is only collected for the controller 0 side.



Note: For AMS500 subsystems, a single output to text file is 500 KB. Multiple outputs increase the file size proportionally. A file with 20,000 outputs requires about 10 GB of disk space.

- **No.:** Output number
- **Information getting time:** Time and date when the information is acquired
- **CTL:** Controller number
- **Port:** Port number
- **IO Rate (IOPS):** Number of Read/Write commands received per second
- **Read Rate (IOPS):** Number of Read commands received per second
- **Write Rate (IOPS):** Number of Write commands received per second
- **Read Hit (%):** Rate of the number of the Read commands, which could cache-hitting, out of the Read commands received in the specified period
- **Write Hit (%):** Rate of the number of the Write commands, which could write data immediately to the cache, out of the Write commands received in the specified period
- **Trans. Rate (MB/S):** Transfer size of Read/Write commands per second
- **Read Trans. Rate (MB/S):** Transfer size of Read commands per second
- **Write Trans. Rate (MB/S):** Transfer size of Write commands per second
- **Read CMD Count:** Received number of Read commands
- **Write CMD Count:** Received number of Write command
- **Read CMD Hit Count:** Number of the Read commands that had been cache-hit
- **Write CMD Hit Count:** Number of the Write commands, which could write data immediately to the cache
- **Read Trans. Size (MB):** Transfer size of Read commands
- **Write Trans. Size (MB):** Transfer size of Write commands
- **RG:** RAID group number
- **LU:** Logical unit number
- **Read CMD Hit Count2:** Number of the Hit Read Special Path commands out of the read commands that made cache hits
- **Read CMD Hit Time(microsec.):** The average response time of the Hit Read Special Path command
- **Read CMD Hit Max Time(microsec.):** The maximum response time of the Hit Read Special Path command

- **Write CMD Hit Count2:** Number of the Write Special Path commands out of the Write commands, which could write data immediately to the cache
- **Write CMD Hit Time(microsec.):** The average response time of the Write Special Path command
- **Write CMD Hit Max Time(microsec.):** The maximum response time of the Write Special Path command
- **Read CMD Miss Count:** The number of the Miss Read Special Path commands out of the Read commands that made no cache hits
- **Read CMD Miss Time(microsec.):** The average response time of the Miss Read Special Path command
- **Read CMD Miss Max Time(microsec.):** The maximum response time of the Miss Read Special Path command
- **Write CMD Miss Count:** The number of the Random Write Special Path commands that could complete the high-speed process up to the parity generation that is an extended process of the Write command
- **Write CMD Miss Time(microsec.):** The average response time of the Random Write Special Path command
- **Write CMD Miss Max Time(microsec.):** The maximum response time of the Random Write Special Path command
- **Read CMD Job Count:** The number of the Read commands that could not perform the high-speed process
- **Read CMD Job Time(microsec.):** The average response time of the Read command job
- **Read CMD Job Max Time(microsec.):** The maximum response time of the Read command job
- **Write CMD Job Count:** The number of the Write commands that could not perform the high-speed process
- **Write CMD Job Time(microsec.):** The average response time of the Write command job
- **Write CMD Job Max Time(microsec.):** The maximum response time of the Write command job
- **Read Hit Delay CMD Count(<300ms):** The number of commands, whose response time is 100 ms to less than 300 ms, out of the Hit Read Special Path commands
- **Read Hit Delay CMD Count(300-499ms):** The number of commands, whose response time is in a range of 300 ms to 499 ms, out of the Hit Read Special Path commands
- **Read Hit Delay CMD Count(500-999ms):** The number of commands, whose response time is in a range of 500 ms to 999 ms, out of the Hit Read Special Path commands

- **Read Hit Delay CMD Count(1000ms-):** The number of commands, whose response time is 1000 ms or more, out of the Hit Read Special Path commands
- **Write Hit Delay CMD Count(<300ms):** The number of commands, whose response time is 100 ms to less than 300 ms, out of the Write Special Path commands
- **Write Hit Delay CMD Count(300-499ms):** The number of commands, whose response time is in a range of 300 ms to 499 ms, out of the Write Special Path commands
- **Write Hit Delay CMD Count(500-999ms):** The number of commands, whose response time is in a range of 500 ms to 999 ms, out of the Write Special Path commands
- **Write Hit Delay CMD Count(1000ms-):** The number of commands, whose response time is 1000 ms or more, out of the Write Special Path commands
- **Read Miss Delay CMD Count(<300ms):** The number of commands, whose response time is 100 ms to less than 300 ms, out of the Miss Read Special Path commands
- **Read Miss Delay CMD Count(300-499ms):** The number of commands, whose response time is in a range of 300 ms to 499 ms, out of the Miss Read Special Path commands
- **Read Miss Delay CMD Count(500-999ms):** The number of commands, whose response time is in a range of 500 ms to 999 ms, out of the Miss Read Special Path commands
- **Read Miss Delay CMD Count(1000ms-):** The number of commands, whose response time is 1000 ms or more, out of the Miss Read Special Path commands
- **Write Miss Delay CMD Count(<300ms):** The number of commands, whose response time is 100 ms to less than 300 ms, out of the Random Write Special Path commands
- **Write Miss Delay CMD Count(300-499ms):** The number of commands, whose response time is in a range of 300 ms to 499 ms, out of the Random Write Special Path commands
- **Write Miss Delay CMD Count(500-999ms):** The number of commands, whose response time is in a range of 500 ms to 999 ms, out of the Random Write Special Path commands
- **Write Miss Delay CMD Count(1000ms-):** The number of commands, whose response time is 1000 ms or more, out of the Random Write Special Path commands
- **Read Job Delay CMD Count(<300ms):** The number of commands, whose response time is 100 ms to less than 300 ms, out of the Read command job

- **Read Job Delay CMD Count(300-499ms):** The number of commands, whose response time is in a range of 300 ms to 499 ms, out of the Read command job
- **Read Job Delay CMD Count(500-999ms):** The number of commands, whose response time is in a range of 500 ms to 999 ms, out of the Read command job
- **Read Job Delay CMD Count(1000ms-):** The number of commands, whose response time is 1000 ms or more, out of the Read command job
- **Write Job Delay CMD Count(<300ms):** The number of commands, whose response time is 100 ms to less than 300 ms, out of the Write command job
- **Write Job Delay CMD Count(300-499ms):** The number of commands, whose response time is in a range of 300 ms to 499 ms, out of the Write command job
- **Write Job Delay CMD Count(500-999ms):** The number of commands, whose response time is in a range of 500 ms to 999 ms, out of the Write command job
- **Write Job Delay CMD Count(1000ms-):** The number of commands, whose response time is 1000 ms or more, out of the Write command job
- **Tag Count:** The maximum number of tags in the specified period
- **Data CMD IO Rate (IOPS):** Sent number of data commands of TrueCopy Initiator per second (acquired local side only)
- **Data CMD Trans. Rate (MB/s):** Transfer size of data commands of TrueCopy Initiator per second (acquired local side only)
- **Data CMD Count:** The data commands count of TrueCopy Initiator (acquired local side only)
- **Data CMD Trans. Size (MB):** Transfer size of data commands of TrueCopy Initiator (acquired local side only)
- **Data CMD Time (microsec.):** Average response time of data commands of TrueCopy Initiator (acquired local side only)
- **Data CMD Max Time (microsec.):** Maximum response time of data commands of TrueCopy Initiator (acquired local side only)
- **Cache Write Pending Rate (%):** Rate of cache usage capacity (middle+physical) within the cache capacity
- Cache Clean Queue Usage Rate (%): Rate of clean cache usage
- Cache Middle Queue Usage Rate (%): Rate of middle cache usage
- Cache Physical Queue Usage Rate (%): Rate of physical cache usage
- Cache Total Queue Usage Rate (%): Rate of total cache usage
- **Partition:** Partition number

- **Usage (%):** Operation rate of the processor
- **Host-Cache Bus Usage Rate (%):** The use rate of the bus between the host and the cache
- **Drive-Cache Bus Usage Rate (%):** The use rate of the bus between the drive and the cache
- **Processor-Cache Bus Usage Rate (%):** The use rate of the bus between the processor and the cache
- **Cache (DRR) Bus Usage Rate (%):** The use rate of the bus between the parity generation circuit (DRR) and the cache
- **Dual Bus Usage Rate (%):** The use rate of the bus between the controllers
- **Total Bus Usage Rate (%):** The total use rate of the cache bus
- **Unit:** Unit number
- **HDU:** HDU number
- **Online Verify. Rate (IOPS):** Number of Online Verify commands per second
- **Online Verify CMD Count:** Number of Online Verify commands
- **Operating Rate (%):** Operation rate of the drive
- **Tag Count:** Number of Tag
- **Unload Time (min.):** Unload time of the drive
- **Path:** Path number
- **Loop:** Loop number

Automatically Outputting Performance Statistics to a Text File

Command operation state for each logical unit in the subsystem is output at the specified intervals by the specified times.

1. On the **Tools** menu, select **Performance** or click .

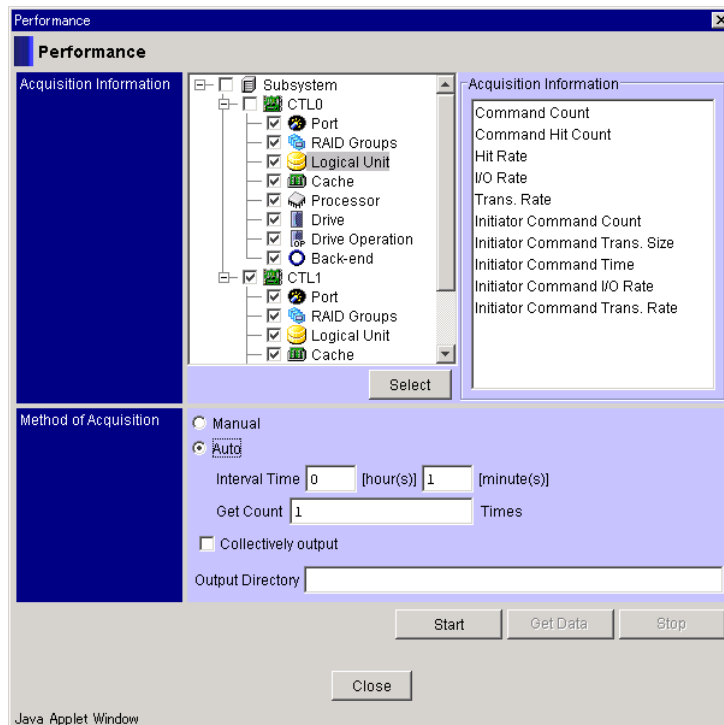

2. Select a component name (**Port**, **RAID Groups**, **Logical Unit**, **Cache**, **Processor**, **Drive**, **Drive Operation**, or **Back-end**) for information about the controller.
3. Specify the extent to be output using **Select**, excluding the **Cache** and **Processor**. When the extent is not specified, all is output. For example, when you want to specify an extent of information on the **Logical Unit**, select the **Logical Unit** icon, click **Select**, and specify the extent of the **Logical Unit**.
4. Select the **Auto** option.
5. Specify the **Interval Time** and **Get Count** Times.
6. When you want to make an output as an addition to the information previously output, check the **Collectively output** check box. Do not check this box when you want to overwrite the information that was previously output.
7. Specify the output directory. If the output directory is omitted, it will be outputted to the directory where Navigator 2 is installed.
8. Click **Start**.

A status message displays.

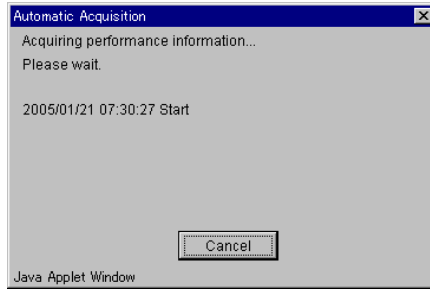

a) When **Collectively output** is not specified:

These files are output in the text file format.

: pfm\$\$\$\$\$.txt (\$\$\$\$\$: serial number from 00000 to 19999)



Note: Files are output with the names of pfm00000.txt to pfm19999.txt. After pfm19999.txt, pfm00000.txt is overwritten. Transfer necessary information to another directory.

b) When **Collectively output** is specified:

This file is output in the text file format (pfm.txt).

9. After the file processed terminates, a confirmation message displays. Click **OK**.

When the single system is connected, only information from controller 0 is collected.

The format to the file to be retrieved is the same as that of the file retrieved manually.



Note: For AMS500 subsystems, a single output to text file is 500 KB. Multiple outputs increase the file size proportionally. A file with 20,000 outputs requires about 10 GB of disk space.

Tuning Parameters

Multi Stream Tuning Parameters

1. On the **Tools** menu, click **Tuning Parameter**.

The **Tuning Parameter** panel displays.

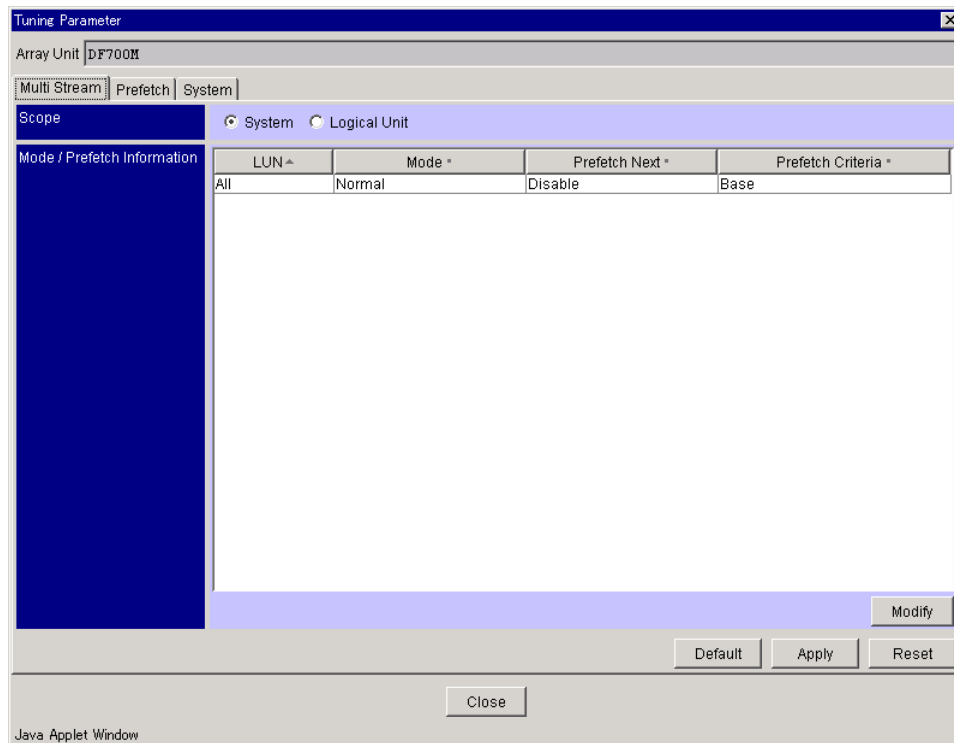

- Scope: Select System or Logical Unit.
- Mode / Prefetch Information:

LUN: Displays **All**.

Mode: Displays **Normal**, **Read**, **Write**, or **Read/Write**.

Prefetch Next: Displays **Disable** or **Enable**.

Prefetch Criteria: Displays **Base** or **Fixed**.

2. When you want to modify the setting, click **Modify**.

The **Prefetch Multi Stream (System)** dialog displays.

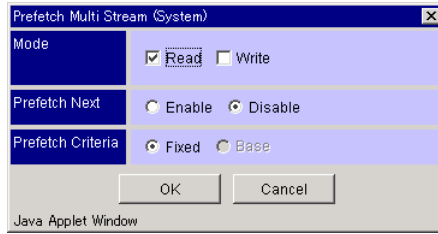

– **Mode:** Specify the mode:

Read: When you select the **Read** mode, specify the **Prefetch Next** Enable or Disable.

Write: When you select the **Write** mode, you cannot specify the **Prefetch Next**.

– **Prefetch Criteria:** Specify the pre-fetch criteria.

3. Specify the parameters and click **OK**.

4. Select the **Logical Unit** on the **Scope**.

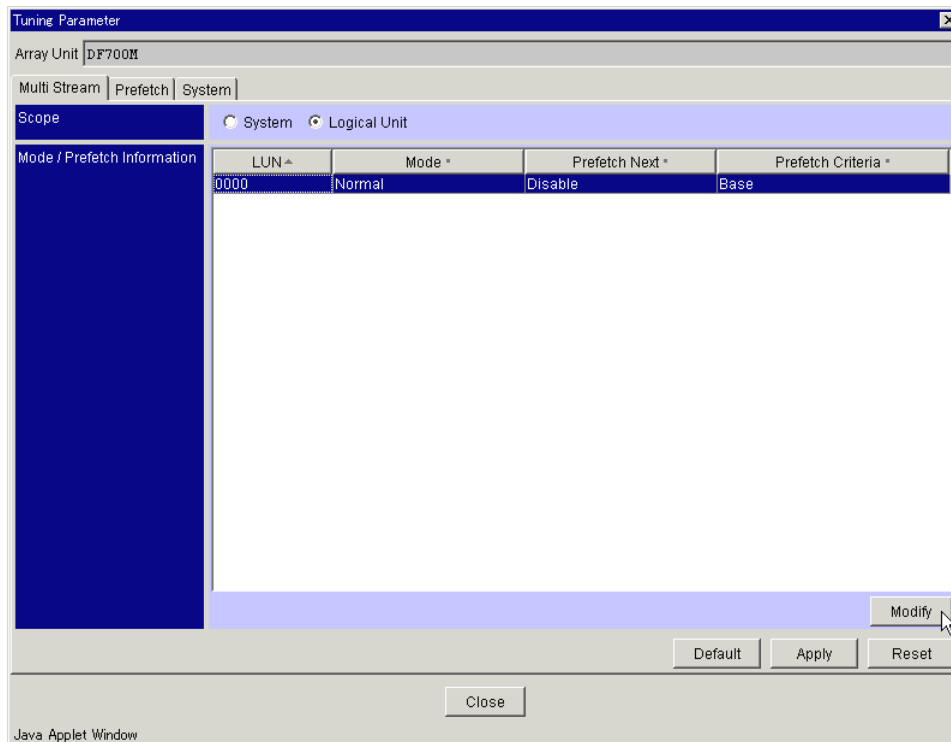

– Scope: Select System or Logical Unit.

– Mode / Prefetch Information:

LUN: Displays logical unit number.

Mode: Displays **Normal**, **Read**, **Write**, or **Read/Write**.

Prefetch Next: Displays **Disable** or **Enable**.

Prefetch Criteria: Displays **Base** or **Fixed**.

5. Select the LUN setting to modify, and click **Modify**.

The **Prefetch Multi Stream (Logical Unit)** dialog displays.

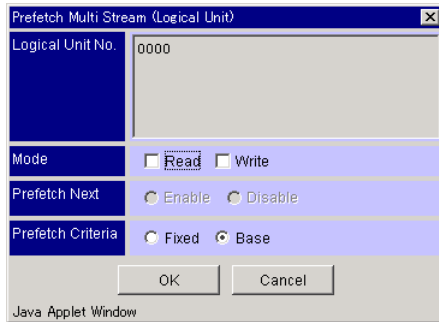

- **Logical Unit No.:** Displays the logical unit number.
- **Mode:** Specify the mode:
 - Read:** When you select the **Read** mode, specify the **Prefetch Next** Enable or Disable. You can specify only **Fixed** in the **Prefetch Criteria**.
 - Write:** When you select the **Write** mode, cannot specify the **Prefetch Next**.
- **Prefetch Criteria:** Specify the pre-fetch criteria.

6. Specify the parameters and click **OK**.
7. Click **Apply** on the **Tuning Parameter** panel.
8. A message displays, stating that the setting is complete. Click **OK**.

To initialize the Multi Stream parameters:

1. When you want to initialize the multi stream parameters, click **Default** on the **Tuning Parameter** panel.
2. A message displays stating that the setting is complete. Click **OK**.

Prefetch Parameters

1. On the **Tools** menu, select **Tuning Parameter**.
The **Tuning Parameter** panel displays.

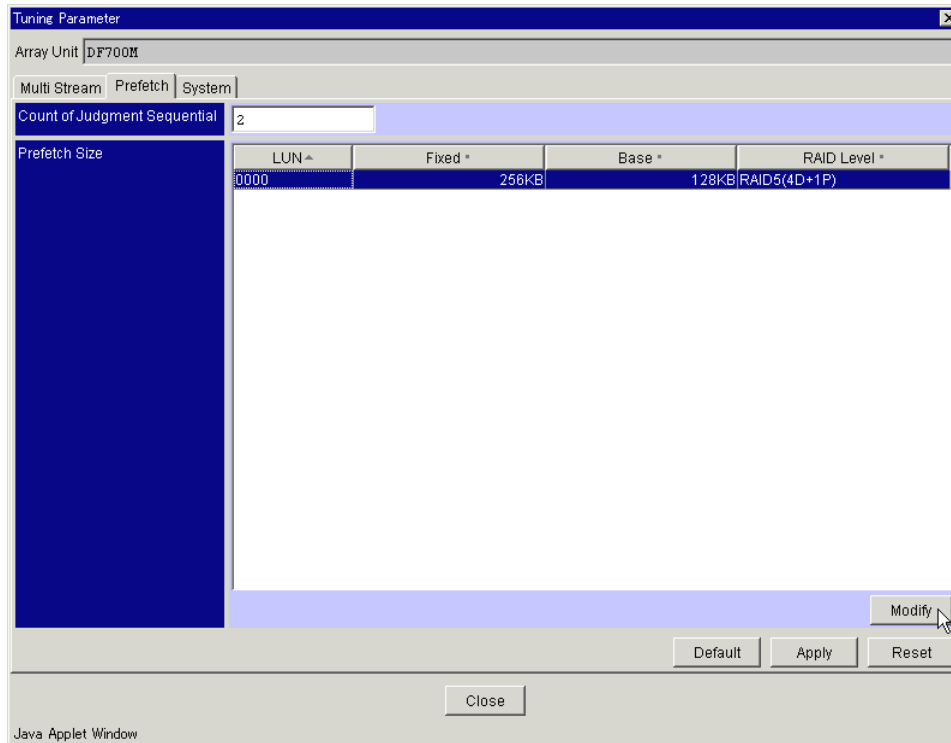

– **Count of Judgment Sequential:** Specify the count of judgment sequential.

2. Select the LUN you want to modify the prefetch size, and then click **Modify**.

The **Prefetch Staging Size** dialog displays.

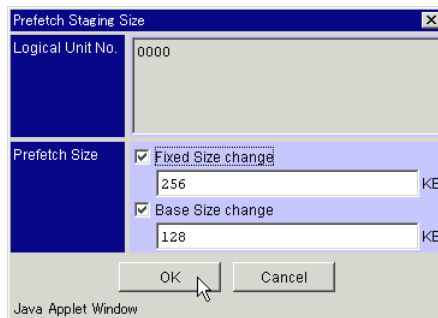

3. Specify **Prefetch Size**, click **OK**.

4. Click **Apply**.

5. The Setting Complete message displays; click **OK**.

To initialize the Prefetch parameters:

1. When you want to initialize the prefetch parameters, click **Default** on the **Prefetch** tab.

2. A message displays stating that the setting is complete. Click **OK**.

Setting System Tuning Parameters

To customize system tuning parameters:

1. From the **Tools** menu, select **Tuning Parameter**.
The **Tuning Parameter** panel displays.
2. Click the **System** tab.

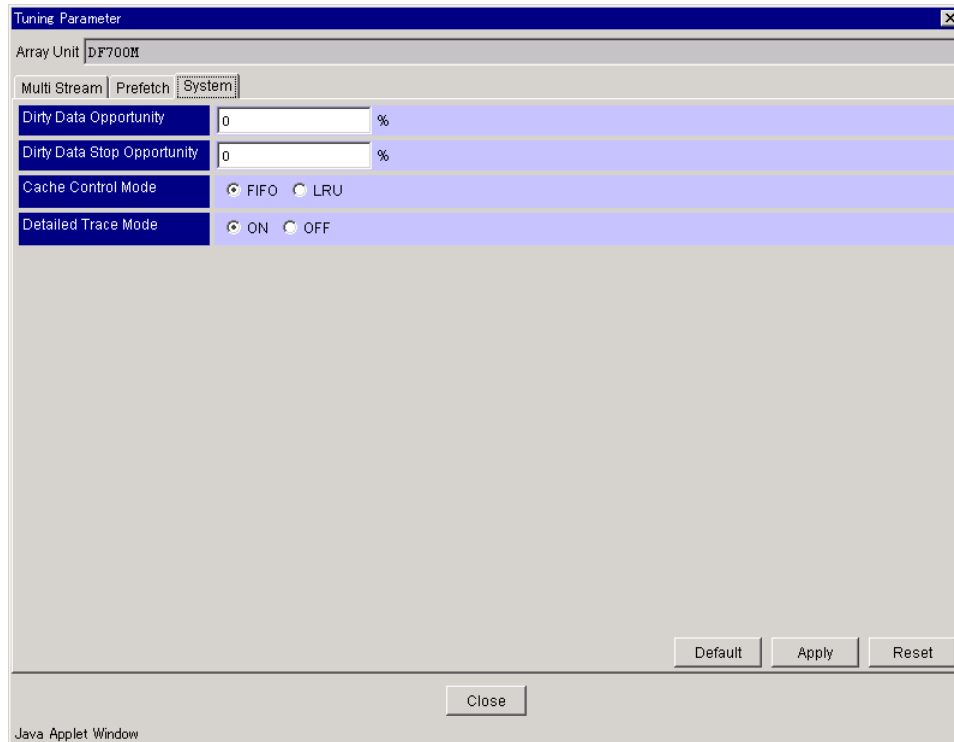

- **Dirty Data Opportunity:** Specify an occasion to de-stage dirty data (%).
 - **Dirty Data Stop Opportunity:** Specify an occasion to stop de-staging dirty data (%).
 - **Cache Control Mode:** Specify the cache control mode.
 - **Detailed Trace Mode:** Specify the detailed trace mode.
3. Click **Apply**.
 4. A confirmation message displays. Click **OK** to apply the settings.

To restore the default system tuning parameters:

1. From the **Tools** menu, select **Tuning Parameter**.
The **Tuning Parameter** panel displays.
2. Click the **System** tab.
3. Click **Default**.

4. A confirmation message displays. Click **OK** to apply the settings.

ACE Tool

When you use the ACE Tool, you can get a connection diagram of the ENC wiring between the additional units and addresses of the additional units that have been set.

Automatic Setting

1. From the **Tools** menu, select the **ACE Tool** on the Array Unit screen.
The **Configuration** panel displays.

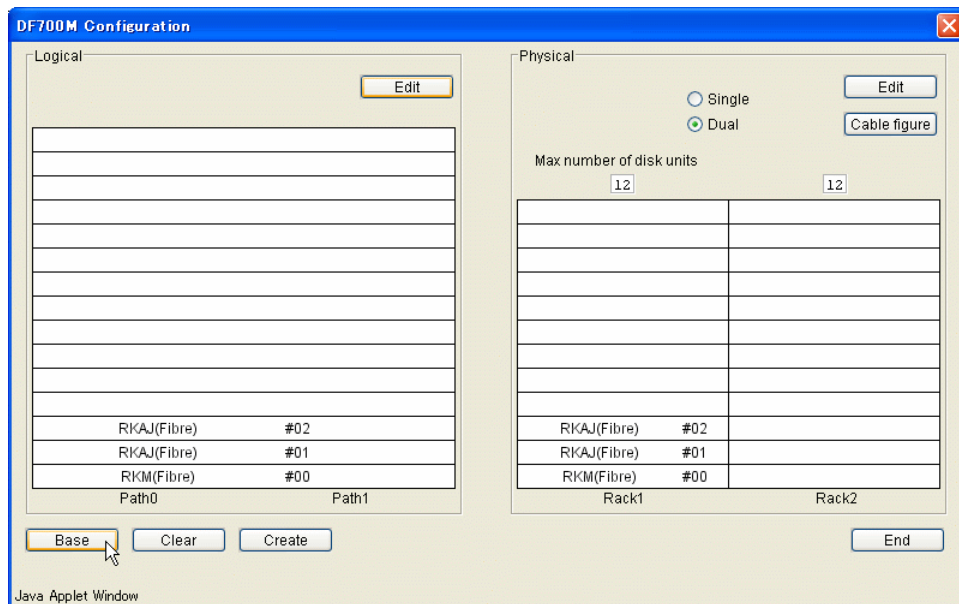

2. Click **Base**.
The **Base** dialog displays.

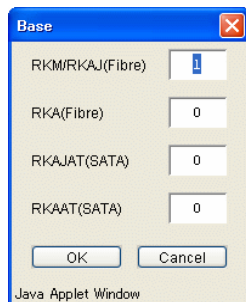

3. Enter a number of units connected to the RKM/RKAJ(Fibre), RKS/RKAJ(Fibre) or RKXS.



Note: The supported expansion cabinets of the WMS100 are currently RKAAT/RKAJAT, but select RKAAT for RKAATL and RKAJAT for RKAJATL. It is displayed as RKAAT for RKAATL and RKAJAT for RKAJATL.

- **WMS100:** The total number of the RKXS and RKAJAT(SATA)/RKAAT (SATA) is not more than 7; the RKXS is one.
- **AMS200:** The total number of the RKS/RKAJs (Fibre) and RKAJATs (SATA) is not more than 7; the RKS/RKAJs(Fibre) is one or more.
- **AMS500:** The total number of the RKM/RKAJs(Fibre) and RKA (Fibre)/RKAJATs (SATA)/RKAATs (SATA) is not more than 15; the RKM/RKAJs(Fibre) is one or more.
- **AMS1000:** The total number of the RKAJs(Fibre) and RKA(Fibre)/RKAJATs (SATA)/RKAATs(SATA) is not more than 30; the RKAJs(Fibre) is one or more.

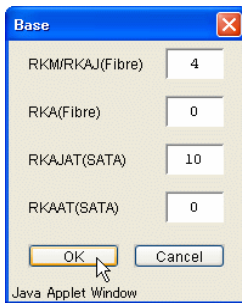

4. Click **OK**.

The ENC wiring connection diagram and addresses of the additional units that have been set are created automatically.

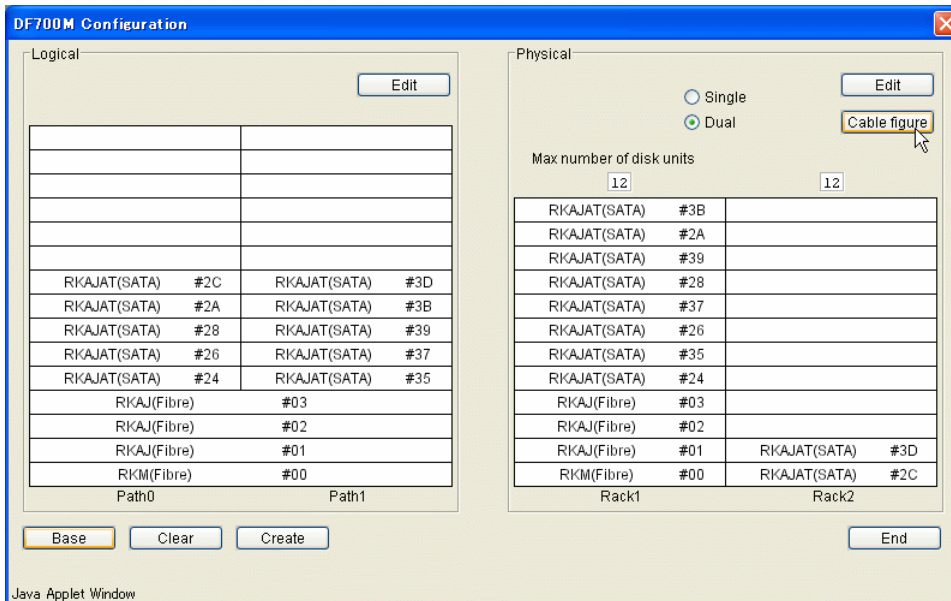

5. Click **Cable figure**.

The **Cable Figure** displays.

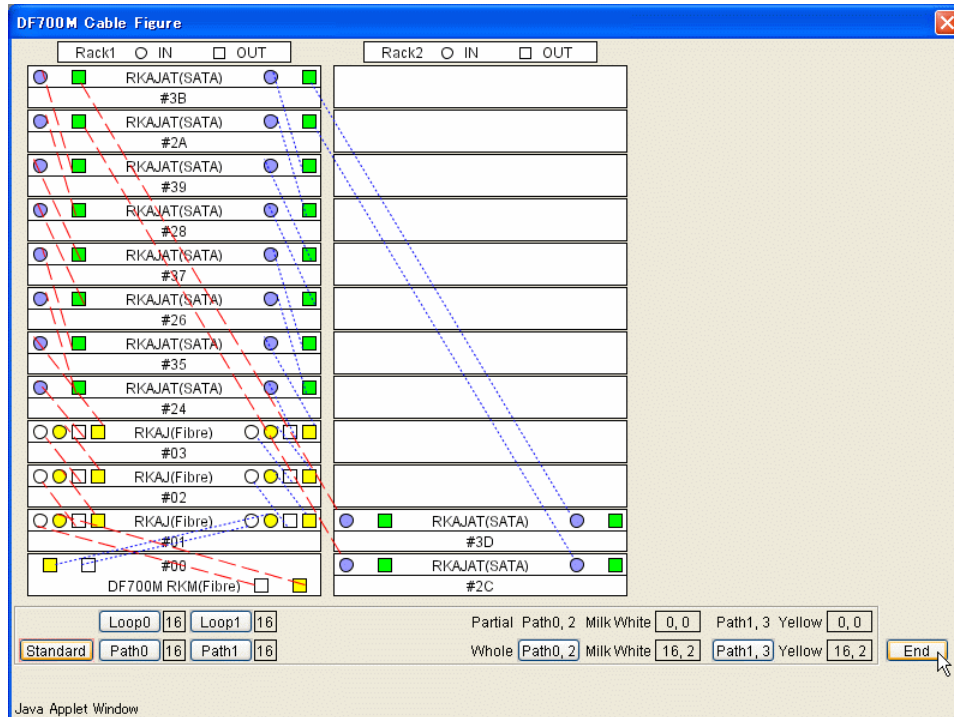

6. Copy and paste the wiring cable figure that has been created when necessary. Click **End**.
7. Click **End**.

Cable Figure Detail

		H		I				J	K			L	M
	Loop0	4	Loop1	4			Partial Path0, 2	Milk White	0, 0	Path1, 3	Yellow	0, 0	
Standard	Path0	4	Path1	4			Whole Path0, 2	Milk White	4, 0	Path1, 3	Yellow	4, 0	
		A		B				C	D	E		C	F

A: Number of cables of the Path 0

B: Number of cables of the Path 1

C: Color of the binders attached to the both ends of the ENC cable

D: Number of cables of the Path 0

E: A number of long inter-rack cables of the Path 0

F: Number of cables of the Path 1

G: A number of long inter-rack cables of the Path 1

H: Number of cables of the Loop 0

I: Number of cables of the Loop 1

J: A number of cables of the Path 0 that are connected to the selected disk array units or added to the additional disk array unit.

K: A number of long inter-rack cables of the Path 0 that are connected to the selected disk array units or added to the additional disk array unit.

L: A number of cables of the Path 1 that are connected to the selected disk array units or added to the additional disk array unit.

M: A number of long inter-rack cables of the Path 1 that are connected to the selected disk array units or added to the additional disk array unit.



Collecting Navigator 2 Diagnostic Information

This appendix provides information on how to collect Navigator 2 diagnostic information using the Navigator 2 CLI.

- [Usage of the Hcmdsgetlogs Command](#)
- [Available Diagnostic Information](#)
- [Acquiring Failure Log at Time of Installation/Un-Installation](#)

- Usage of the Hcmdsgetlogs Command

To collect diagnostic information regarding Navigator 2, use the `hcmdsgetlogs` command. Execute the command in the following format in the `Base\bin` directory under the Navigator 2 installed directory. (Windows is the default):
 C:\Program Files\HiCommand, Linux/Solaris: /opt/Hicommand)

- Command format

Windows:

```
hcmdsgetlogs /dir DirectoryName [ /type StorageNavigatorModular ]
[ /arc FileName ]
```

Linux/Solaris:

```
hcmdsgetlogs -dir DirectoryName [ -type StorageNavigatorModular ]
[ -arc FileName ]
```

- Options

Options and arguments	Description
/dir DirectoryName	Specify the directory that outputs the diagnostic information. The directory must be empty.
/type StorageNavigatorModular	Specify that only the Navigator 2 diagnostic information be collected. If this option is not specified, the command also collects diagnostic information about the other Hitachi Storage Command products installed.
/arc FileName	Specify the name of the diagnostic information file in which collected information will be output. If this option is not specified, the command creates the files with the default names (HiCommand_log.....jar).

Available Diagnostic Information

When you execute the `hcmdsgetlogs` command, the following file is created in the directory specified by the `/dir` option. The following file name is the default file name, and it is created with another file name when specifying the `/arc` option.

File Name (Default)	Description
HiCommand_log.jar	HiCommand Suite Common Component and Navigator 2 specific log
HiCommand_log.hdb.jar	Database detailed log
HiCommand_log.db.jar	Database file
HiCommand_log.csv.jar	Database table data

Acquiring Failure Log Installation or Un-installation

When a failure occurs in the installation or un-installation, acquire a log of the installer or uninstaller using the following procedure.

- When the `hcmdsgetlogs` command is provided
Acquire the log using the procedure the section A.1.
- When the `hcmdsgetlogs` command is not provided or execution of the command fails

When a failure occurs in the middle of the installation or un-installation, the `hcmdsgetlogs` command may be unable to be used. In this case, acquire the following files manually. (An asterisk (“*”) in the file name indicates an optional character string. Acquire all files concerned.)

Windows:

C:\hcmds*

C:\snm2inst*

(When Windows is installed in a place other than the drive C, the file is created immediately under the root folder of a drive in which Windows is installed.)

Linux or Solaris:

/tmp/hcmds*

/tmp/snm2inst*



Performance Output Text File Information

This appendix provides details on the information obtained when acquiring performance information.

- [Working with Acquired Information](#)

Working with Acquired Information

The following table details acquired information.

Table B.1 Acquired Information

Selected Item	List Items	Contents
Port	Port	Port number (The maximum numbers of resources that can be installed in the subsystem are displayed.)
	IO Rate (IOPS)	Received number of Read/Write commands per second
	Read Rate (IOPS)	Received number of Read commands per second
	Write Rate (IOPS)	Received number of Write commands per second
	Read Hit (%)	Rate of cache-hitting within the received Read command
	Write Hit (%)	Rate of cache-hitting within the received Write command
	Trans. Rate (MB/s)	Transfer size of Read/Write commands per second
	Read Trans. Rate (MB/s)	Transfer size of Read commands per second
	Write Trans. Rate (MB/s)	Transfer size of Write commands per second
	Read CMD Count	Received number of Read commands
	Write CMD Count	Received number of Write commands
	Read CMD Hit Count	Number of the Read commands that had been cache-hit
	Write CMD Hit Count	Number of the Write commands, which could write data immediately to the cache
	Read Trans. Size (MB)	Transfer size of Read commands
	Write Trans. Size (MB)	Transfer size of Write commands
	CTL CMD IO Rate (IOPS)	Received number of Initiator control commands per second
	Data CMD IO Rate (IOPS)	Received number of Initiator data commands per second
	CTL CMD Trans. Rate (KB/s)	Transfer size of Initiator control commands per second
	Data CMD Trans. Rate (MB/s)	Transfer size of Initiator data commands per second
	CTL CMD Time (microsec.)	Average response time of Initiator commands
	Data CMD Time (microsec.)	Average response time of Initiator data commands
	CTL CMD Count	Number of Initiator control commands
	Data CMD Count	Number of Initiator data commands

	CTL CMD Trans. Size (KB)	Transfer size of Initiator control commands
	Data CMD Trans. Size (MB)	Transfer size of Initiator data commands
	CTL CMD Max Time (microsec.)	Maximum response time of control commands of Initiator
	Data CMD Max Time (microsec.)	Maximum response time of data commands of Initiator
	Timeout Error Count	Timeout error count
	Random IO Rate (IOPS)	Received number of Random Read/Write commands per second
	Random Read Rate (IOPS)	Received number of Random Read commands per second
	Random Write Rate (IOPS)	Received number of Random Write commands per second
	Random Trans. Rate (MB/s)	Transfer size of Random Read/Write commands per second
	Random Read Trans. Rate (MB/s)	Transfer size of Random Read commands per second
	Random Write Trans. Rate (MB/s)	Transfer size of Random Write commands per second
	Random Read CMD Count	Received number of Random Read commands
	Random Write CMD Count	Received number of Random Write commands
	Random Read Trans. Size (MB)	Transfer size of Random Read commands
	Random Write Trans. Size (MB)	Transfer size of Random Write commands
	Sequential IO Rate (IOPS)	Received number of Sequential Read/Write commands per second
	Sequential Read Rate (IOPS)	Received number of Sequential Read commands per second
	Sequential Write Rate (IOPS)	Received number of Sequential Write commands per second
	Sequential Trans. Rate (MB/s)	Transfer size of Sequential Read/Write commands per second
	Sequential Read Trans. Rate (MB/s)	Transfer size of Sequential Read commands per second
	Sequential Write Trans. Rate (MB/s)	Transfer size of Sequential Write commands per second
	Sequential Read CMD Count	Received number of Sequential Read commands
	Sequential Write CMD Count	Received number of Sequential Write commands
	Sequential Read Trans. Size (MB)	Transfer size of Sequential Read commands

	Sequential Write Trans. Size (MB)	Transfer size of Sequential Write commands
	XCOPY Rate (IOPS)	Received number of XCOPY commands per second
	XCOPY Read Rate (IOPS)	Received number of XCOPY Read commands per second
	XCOPY Write Rate (IOPS)	Received number of XCOPY Write commands per second
	XCOPY Read Trans. Rate (MB/s)	Transfer size of XCOPY Read commands per second
	XCOPY Write Trans. Rate (MB/s)	Transfer size of XCOPY Write commands per second
	XCOPY Time (microsec.)	Response time of XCOPY commands
	XCOPY Max Time (microsec.)	Max response time of XCOPY commands
RAID Groups DP Pools	RAID Group/DP Pool	RAID group/DP pool number that have been defined
	IO Rate (IOPS)	Received number of Read/Write commands per second
	Read Rate (IOPS)	Received number of Read commands per second
	Write Rate (IOPS)	Received number of Write commands per second
	Read Hit (%)	Rate of cache-hitting within the received Read command
	Write Hit (%)	Rate of cache-hitting within the received Write command
	Trans. Rate (MB/s)	Transfer size of Read/Write commands per second
	Read Trans. Rate (MB/s)	Transfer size of Read commands per second
	Write Trans. Rate (MB/s)	Transfer size of Write commands per second
	Read CMD Count	Received number of Read commands
	Write CMD Count	Received number of Write commands
	Read CMD Hit Count	Number of the Read commands that had been cache-hit
	Write CMD Hit Count	Number of the Write commands, which could write data immediately to the cache
	Read Trans. Size (MB)	Transfer size of Read commands
	Write Trans. Size (MB)	Transfer size of Write commands
	Random IO Rate (IOPS)	Received number of Random Read/Write commands per second
	Random Read Rate (IOPS)	Received number of Random Read commands per second
	Random Write Rate (IOPS)	Received number of Random Write commands per second
	Random Trans. Rate (MB/s)	Transfer size of Random Read/Write commands per second

	Random Read Trans. Rate (MB/s)	Transfer size of Random Read commands per second
	Random Write Trans. Rate (MB/s)	Transfer size of Random Write commands per second
	Random Read CMD Count	Received number of Random Read commands
	Random Write CMD Count	Received number of Random Write commands
	Random Read Trans. Size (MB)	Transfer size of Random Read commands
	Random Write Trans. Size (MB)	Transfer size of Random Write commands
	Sequential IO Rate (IOPS)	Received number of Sequential Read/Write commands per second
	Sequential Read Rate (IOPS)	Received number of Sequential Read commands per second
	Sequential Write Rate (IOPS)	Received number of Sequential Write commands per second
	Sequential Trans. Rate (MB/s)	Transfer size of Sequential Read/Write commands per second
	Sequential Read Trans. Rate (MB/s)	Transfer size of Sequential Read commands per second
	Sequential Write Trans. Rate (MB/s)	Transfer size of Sequential Write commands per second
	Sequential Read CMD Count	Received number of Sequential Read commands
	Sequential Write CMD Count	Received number of Sequential Write commands
	Sequential Read Trans. Size (MB)	Transfer size of Sequential Read commands
	Sequential Write Trans. Size (MB)	Transfer size of Sequential Write commands
	XCOPY Rate (IOPS)	Received number of XCOPY commands per second
	XCOPY Read Rate (IOPS)	Received number of XCOPY Read commands per second
	XCOPY Write Rate (IOPS)	Received number of XCOPY Write commands per second
	XCOPY Read Trans. Rate (MB/s)	Transfer size of XCOPY Read commands per second
	XCOPY Write Trans. Rate (MB/s)	Transfer size of XCOPY Write commands per second
	XCOPY Time (microsec.)	Response time of XCOPY commands
	XCOPY Max Time (microsec.)	Max response time of XCOPY commands
Logical Unit DP Pool	LUN	Logical unit number that have been defined
	IO Rate (IOPS)	Received number of Read/Write commands per second

	Read Rate (IOPS)	Received number of Read commands per second
	Write Rate (IOPS)	Received number of Write commands per second
	Read Hit (%)	Rate of cache-hitting within the received Read command
	Write Hit (%)	Rate of cache-hitting within the received Write command
	Trans. Rate (MB/s)	Transfer size of Read/Write commands per second
	Read Trans. Rate (MB/s)	Transfer size of Read commands per second
	Write Trans. Rate (MB/s)	Transfer size of Write commands per second
	Read CMD Count	Received number of Read commands
	Write CMD Count	Received number of Write commands
	Read CMD Hit Count	Number of the Read commands that had been cache-hit
	Write CMD Hit Count	Number of the Write commands, which could write data immediately to the cache
	Read Trans. Size (MB)	Transfer size of Read commands
	Write Trans. Size (MB)	Transfer size of Write commands
	Read CMD Hit Count2	Number of the Hit Read Special Path commands out of the read commands that made cache hits
	Read CMD Hit Time (microsec.)	The average response time of the Hit Read Special Path commands
	Read CMD Hit Max Time (microsec.)	The maximum response time of the Hit Read Special Path commands
	Write CMD Hit Count2	Number of the Write Special Path commands out of the Write commands, which could write data immediately to the cache
	Write CMD Hit Time (microsec.)	The average response time of the Write Special Path commands
	Write CMD Hit Max Time (microsec.)	The maximum response time of the Write Special Path commands
	Read CMD Miss Count	The number of the Miss Read Special Path commands out of the Read commands that made no cache hits
	Read CMD Miss Time (microsec.)	The average response time of the Miss Read Special Path commands
	Read CMD Miss Max Time (microsec.)	The maximum response time of the Miss Read Special Path commands
	Write CMD Miss Count	The number of the Random Write Special Path commands that could complete the high-speed process up to the parity generation that is an extended process of the Write commands
	Write CMD Miss Time (microsec.)	The average response time of the Random Write Special Path commands
	Write CMD Miss Max Time (microsec.)	The maximum response time of the Random Write Special Path commands

	Read CMD Job Count	The number of the Read commands that could not perform the high-speed process
	Read CMD Job Time (microsec.)	The average response time of the Read command job
	Read CMD Job Max Time (microsec.)	The maximum response time of the Read command job
	Write CMD Job Count	The number of the Write commands that could not perform the high-speed process
	Write CMD Job Time (microsec.)	The average response time of the Write command job
	Write CMD Job Max Time (microsec.)	The maximum response time of the Write command job
	Read Hit Delay CMD Count (<300 ms)	The number of commands, whose response time is 100 ms to less than 300 ms, out of the Hit Read Special Path commands
	Read Hit Delay CMD Count (300-499 ms)	The number of commands, whose response time is in a range of 300 ms to 499 ms, out of the Hit Read Special Path commands
	Read Hit Delay CMD Count (500-999 ms)	The number of commands, whose response time is in a range of 500 ms to 999 ms, out of the Hit Read Special Path commands
	Read Hit Delay CMD Count (1000 ms-)	The number of commands, whose response time is 1000 ms or more, out of the Hit Read Special Path commands
	Write Hit Delay CMD Count (<300 ms)	The number of commands, whose response time is 100 ms to less than 300 ms, out of the Write Special Path commands
	Write Hit Delay CMD Count (300-499 ms)	The number of commands, whose response time is in a range of 300 ms to 499 ms, out of the Write Special Path commands
	Write Hit Delay CMD Count (500-999 ms)	The number of commands, whose response time is in a range of 500 ms to 999 ms, out of the Write Special Path commands
	Write Hit Delay CMD Count (1000 ms-)	The number of commands, whose response time is 1000 ms or more, out of the Write Special Path commands
	Read Miss Delay CMD Count (<300 ms)	The number of commands, whose response time is 100 ms to less than 300 ms, out of the Miss Read Special Path commands
	Read Miss Delay CMD Count (300-499 ms)	The number of commands, whose response time is in a range of 300 ms to 499 ms, out of the Miss Read Special Path commands
	Read Miss Delay CMD Count (500-999 ms)	The number of commands, whose response time is in a range of 500 ms to 999 ms, out of the Miss Read Special Path commands
	Read Miss Delay CMD Count (1000 ms-)	The number of commands, whose response time is 1000 ms or more, out of the Miss Read Special Path commands
	Write Miss Delay CMD Count (<300 ms)	The number of commands, whose response time is 100 ms to less than 300 ms, out of the Random Write Special Path commands

	Write Miss Delay CMD Count (300-499 ms)	The number of commands, whose response time is in a range of 300 ms to 499 ms, out of the Random Write Special Path commands
	Write Miss Delay CMD Count (500-999 ms)	The number of commands, whose response time is in a range of 500 ms to 999 ms, out of the Random Write Special Path commands
	Write Miss Delay CMD Count (1000 ms-)	The number of commands, whose response time is 1000 ms or more, out of the Random Write Special Path commands
	Read Job Delay CMD Count (<300 ms)	The number of commands, whose response time is 100 ms to less than 300 ms, out of the Read command job
	Read Job Delay CMD Count (300-499 ms)	The number of commands, whose response time is in a range of 300 ms to 499 ms, out of the Read command job
	Read Job Delay CMD Count (500-999 ms)	The number of commands, whose response time is in a range of 500 ms to 999 ms, out of the Read command job
	Read Job Delay CMD Count (1000 ms-)	The number of commands, whose response time is 1000 ms or more, out of the Read command job
	Write Job Delay CMD Count (<300 ms)	The number of commands, whose response time is 100 ms to less than 300 ms, out of the Write command job
	Write Job Delay CMD Count (300-499 ms)	The number of commands, whose response time is in a range of 300 ms to 499 ms, out of the Write command job
	Write Job Delay CMD Count (500-999 ms)	The number of commands, whose response time is in a range of 500 ms to 999 ms, out of the Write command job
	Write Job Delay CMD Count (1000 ms-)	The number of commands, whose response time is 1000 ms or more, out of the Write command job
	Tag Count (Logical Unit only)	Maximum multiplicity of commands between intervals
	Average Tag Count (Logical Unit only)	Average multiplicity of commands between intervals
	Data CMD IO Rate (IOPS)	Sent number of Initiator data commands per second
	Data CMD Trans. Rate (MB/s)	Transfer size of Initiator data commands per second
	Data CMD Count	Received number of Initiator data commands
	Data CMD Trans. Size (MB)	Transfer size of Initiator data commands
	Data CMD Time (microsec.)	Response time of Initiator data commands
	Data CMD Max Time (microsec.)	Max response time of Initiator data commands
	Random IO Rate (IOPS)	Received number of Random Read/Write commands per second
	Random Read Rate (IOPS)	Received number of Random Read commands per second

	Random Write Rate (IOPS)	Received number of Random Write commands per second
	Random Trans. Rate (MB/s)	Transfer size of Random Read/Write commands per second
	Random Read Trans. Rate (MB/s)	Transfer size of Random Read commands per second
	Random Write Trans. Rate (MB/s)	Transfer size of Random Write commands per second
	Random Read CMD Count	Received number of Random Read commands
	Random Write CMD Count	Received number of Random Write commands
	Random Read Trans. Size (MB)	Transfer size of Random Read commands
	Random Write Trans. Size (MB)	Transfer size of Random Write commands
	Sequential IO Rate (IOPS)	Received number of Sequential Read/Write commands per second
	Sequential Read Rate (IOPS)	Received number of Sequential Read commands per second
	Sequential Write Rate (IOPS)	Received number of Sequential Write commands per second
	Sequential Trans. Rate (MB/s)	Transfer size of Sequential Read/Write commands per second
	Sequential Read Trans. Rate (MB/s)	Transfer size of Sequential Read commands per second
	Sequential Write Trans. Rate (MB/s)	Transfer size of Sequential Write commands per second
	Sequential Read CMD Count	Received number of Sequential Read commands
	Sequential Write CMD Count	Received number of Sequential Write commands
	Sequential Read Trans. Size (MB)	Transfer size of Sequential Read commands
	Sequential Write Trans. Size (MB)	Transfer size of Sequential Write commands
	XCOPY Rate (IOPS)	Received number of XCOPY commands per second
	XCOPY Read Rate (IOPS)	Received number of XCOPY Read commands per second
	XCOPY Write Rate (IOPS)	Received number of XCOPY Write commands per second
	XCOPY Read Trans. Rate (MB/s)	Transfer size of XCOPY Read commands per second
	XCOPY Write Trans. Rate (MB/s)	Transfer size of XCOPY Write commands per second
	XCOPY Time (microsec.)	Response time of XCOPY commands
	XCOPY Max Time (microsec.)	Max response time of XCOPY commands

Cache	Write Pending Rate (%)	Rate of cache usage capacity within the cache capacity
	Clean Queue Usage Rate (%)	Clean cache usage rate
	Middle Queue Usage Rate (%)	Middle cache usage rate
	Physical Queue Usage Rate (%)	Physical cache usage rate
	Total Queue Usage Rate (%)	Total cache usage rate
Processor	Usage (%)	Operation rate of the processor
	Host-Cache Bus Usage Rate (%)	The use rate of the bus between the host and the cache
	Drive-Cache Bus Usage Rate (%)	The use rate of the bus between the drive and the cache
	Processor-Cache Bus Usage Rate (%)	The use rate of the bus between the processor and the cache
	Cache (DRR) Bus Usage Rate (%)	The use rate of the bus between the parity generation circuit (DRR) and the cache
	Dual Bus Usage Rate (%)	The use rate of the bus between the controllers
	Total Bus Usage Rate (%)	The total use rate of the cache bus
Drive	Unit	Unit number (The maximum numbers of resources that can be installed in the subsystem are displayed.)
	HDU	HDU number (The maximum numbers of resources that can be installed in the subsystem are displayed.)
	IO Rate (IOPS)	Received number of Read/Write commands per second
	Read Rate (IOPS)	Received number of Read commands per second
	Write Rate (IOPS)	Received number of Write commands per second
	Trans. Rate (MB/s)	Transfer size of Read/Write commands per second
	Read Trans. Rate (MB/s)	Transfer size of Read commands per second
	Write Trans. Rate (MB/s)	Transfer size of Write commands per second
	Online Verify Rate (IOPS)	Number of Online Verify commands per second
	Read CMD Count	Received number of Read commands
	Write CMD Count	Received number of Write commands
	Read Trans. Size (MB)	Transfer size of Read commands
	Write Trans. Size (MB)	Transfer size of Write commands
	Online Verify CMD Count	Number of Online Verify commands
Drive Operation	Unit	Unit number (The maximum numbers of resources that can be installed in the subsystem are displayed.)
	HDU	HDU number (The maximum numbers of resources that can be installed in the subsystem are displayed.)

	Operating Rate (%)	Operation rate of the drive
	Tag Count	Maximum multiplicity of drive commands between intervals
	Unload Time (min.)	Unload time of the drive
	Tag Average	Average multiplicity of drive commands between intervals
Back-end	Path	Path number (The maximum numbers of resources that can be installed in the subsystem are displayed.)
	IO Rate (IOPS)	Received number of Read/Write commands per second
	Read Rate (IOPS)	Received number of Read commands per second
	Write Rate (IOPS)	Received number of Write commands per second
	Trans. Rate (MB/s)	Transfer size of Read/Write commands per second
	Read Trans. Rate (MB/s)	Transfer size of Read commands per second
	Write Trans. Rate (MB/s)	Transfer size of Write commands per second
	Online Verify Rate (IOPS)	Number of Online Verify commands per second
	Read CMD Count	Received number of Read commands
	Write CMD Count	Received number of Write commands
	Read Trans. Size (MB)	Transfer size of Read commands
	Write Trans. Size (MB)	Transfer size of Write commands
	Online Verify CMD Count	Number of Online Verify commands



Note: For the cache hit of the Write command, the Write command performs the operation (write after) to respond to a host with the status at the time of completing write to the cache memory. Therefore, a case where write to the cache memory is immediately performed is defined as a hit and a case where write to the cache memory is waited for a reason that the cache memory is heavily used, etc. is defined as a miss.



Acronyms and Abbreviations

CHAP challenge handshake authentication protocol
CLI command line interface

DAMP Disk Array Management Program
DDL data definition language
DHCP dynamic host configuration protocol

GB gigabyte
GUI graphical user interface

HACMP High Availability Cluster Multi-Processing
HDLM Hitachi Dynamic Link Manager
HDU hard disk unit

I/O input/output

JRE Java Runtime Environment

LAN local area network
LIP loop initialization primitive
LU logical unit
LUN logical unit number

MB megabyte

NTP network time protocol

OS operating system

PC personal computer
PS power supply
PSUE pair suspended-error
PSUS pair suspended-split
PV physical volume
P-VOL primary volume

RAID redundant array of independent disks
RTC real-time clock

SCSI small computer system interface
SMPL simplex

SNMP simple network management protocol
S-VOL secondary volume
TID target ID
VCS VERITAS Cluster Server
VxVM VERITAS Volume Manager™



Glossary

This glossary defines the special terms used in this document.

#

1000Base-T

A specification for Gigabit Ethernet over copper wire. The standard defines 1 Gbps data transfer over distances of up to 100 meters using four pairs of Category 5 balanced copper cabling and a 5-level coding scheme.

A

abscissa

The horizontal coordinate of a point to in a plane Cartesian coordinate system obtained by measuring parallel to the x-axis.

API

Application Programming Interface.

array

A set of hard disks mounted in a single enclosure and grouped logically together to function as one contiguous storage space.

asynchronous

Asynchronous data communications operate between a computer and various devices. Data transfers occur intermittently rather than in a steady stream. Asynchronous replication does not depend on acknowledging the remote write, but it does write to a local log file. Synchronous replication depends on receiving an acknowledgement code (ACK) from the remote system and the remote system also keeps a log file.

ATA

Advanced Technology Attachment, a disk drive implementation that integrates the controller on the disk drive.

ATM

Asynchronous Transfer Mode, a cell relay, packet switching network and data link layer protocol which encodes data traffic into small (53 bytes; 48 bytes of data and 5 bytes of header information) fixed-sized cells. ATM provides data link layer services that run over Layer 1 links. This differs from other technologies based on packet-switched networks (such as the Internet Protocol or Ethernet), in which variable sized packets are used. ATM is a connection-oriented technology, in which a logical connection is established between the two endpoints before the actual data exchange begins.

B**background copy**

A physical copy of all tracks from the source volume to the target volume.

bind

To assign a value to a symbolic placeholder. For example, when a program is bound, or linked, the binder (Bind) replaces the symbolic addresses in the code with real machine addresses.

BIOS

Basic Input Output System, built-in software code that determines the functions that a computing device can perform without accessing programs from a disk.

bps

Bits per second, the standard measure of data transmission speeds.

BSD syslog protocol

A protocol used for the transmission of event notification messages across networks for many years. Originally developed for the University of California Berkeley Software Distribution (BSD) TCP/IP system implementations, its value to operations and management has led it to be ported to other operating systems and to being embedded into many other networked devices.

C

cache

A temporary, high-speed storage mechanism. It is a reserved section of main memory or an independent high-speed storage device. Two types of caching are found in computers: memory caching and disk caching. Memory caches are built into the architecture of microprocessors and often computers have external cache memory. Disk caching works like memory caching; however, it uses slower, conventional main memory that on some devices is called a memory buffer.

cache fast write (CFW)

An attribute of record caching in which the cache fast write access function (either Simplex Write or Duplex Write) enables the specified record ID to be placed in the volatile control unit cache when a file-type macro is issued and the cache is available. If the cache is not available, the record is written directly to the DASD surface. A single write is issued to the prime module only or a duplexed write is issued to both the prime and the duplicate modules.

Canadian Electroacoustic Community

Canada's national electroacoustic / computer music / sonic arts organization.

capacity

The amount of information (usually expressed in megabytes) that can be stored on a disk drive. It is the measure of the potential contents of a device; the volume it can contain or hold. In communications, capacity refers to the maximum possible data transfer rate of a communications channel under ideal conditions.

cascade configuration

A cascade configuration is a connection configuration of volume pairs. Either the P-VOL or S-VOL from a pair belonging to one copy function, is used as a P-VOL or S-VOL for the other copy function. TrueCopy Extended Distance supports cascading with ShadowImage and SnapShot.

CCI

See command control interface.

Challenge Handshake Authentication Protocol (CHAP)

A security protocol that requires users to enter a secret for access.

channel

The link between the central processor and the peripherals. A channel can be the physical cabling that connects the nodes on a network, an electronic signal traveling over a pathway, or a sub-channel in a carrier frequency.

channel adapter (CHA)

Provides the channel interface control functions and inter-cache data transfer functions. It is used to convert the data format between count-key data and fixed block architecture. The CHA contains an internal processor and 128 bytes of edit buffer memory. A more modern term for channel adapter is front end director (FED). The opposite is back end director (BED) which may also be called DKA in some HDS manuals.

channel extender

A device used to increase the communication distances between channel-connected mainframe computers or between a computer and peripheral devices such as workstations, printers, and storage devices. Optical fiber channel connections are part of the system.

CHAP

See Challenge Handshake Authentication Protocol.

CLI

See command line interface.

cluster

A group of disk sectors. The operating system assigns a unique number to each cluster and then keeps track of files according to which clusters they use.

cluster capacity

The total amount of disk space in a cluster, excluding the space required for system overhead and the operating system. Cluster capacity is the amount of space available for all archive data, including original file data, metadata, and redundant data.

command control interface (CCI)

Hitachi's Command Control Interface software provides command line control of Hitachi array and software operations through the use of commands issued from a system host. Hitachi's CCI also provides a scripting function for defining multiple operations.

command devices

Dedicated logical volumes that are used only by management software such as CCI, to interface with the storage systems. Command devices are not used by ordinary applications. Command devices can be shared between several hosts.

command line interface (CLI)

A method of interacting with an operating system or software using a command line interpreter. With Hitachi's Storage Navigator Modular Command Line Interface, CLI is used to interact with and manage Hitachi storage and replication systems.

compression

The process of encoding data to reduce its size. Most IT applications use lossless compression, in which a technique is used that preserves the entire content of the original data, and from which the original data can be reconstructed exactly.

concurrency of S-VOL

Occurs when an S-VOL is synchronized by simultaneously updating an S-VOL with P-VOL data AND data cached in the primary host memory. Discrepancies in S-VOL data may occur if data is cached in the primary host memory between two write operations. This data, which is not available on the P-VOL, is not reflected on to the S-VOL. To ensure concurrency of the S-VOL, cached data is written onto the P-VOL before subsequent remote copy operations take place.

concurrent copy

A management solution that creates data dumps, or copies, while other applications are updating that data. This allows end-user processing to continue. Concurrent copy allows you to update the data in the files being copied, however, the copy or dump of the data it secures does not contain any of the intervening updates.

configuration definition file

The configuration definition file describes the system configuration for making CCI operational in a TrueCopy Extended Distance Software environment. The configuration definition file is a text file created and/or edited using any standard text editor, and can be defined from the PC where the CCI software is installed. The configuration definition file describes configuration of new TrueCopy Extended Distance pairs on the primary or remote storage system.

consistent internal data

In TrueCopy Extended Distance, after an update to the remote S-VOL is completed, the updated data is copied to the data pool. If a failure occurs during the subsequent update to the S-VOL (for example, an accident occurs at the primary site or the line is disconnected), the update is lost and the write sequence is not guaranteed. The remote storage system can restore the S-VOL using the consistent internal data from the previous update cycle that was stored in the data pool.

consistency group (CTG)

A group of two or more logical units in a file system or a logical volume. When a file system or a logical volume which stores application data, is configured from two or more logical units, these multiple logical units are managed as a consistency group (CTG) and treated as a single entity. A set of volume pairs can also be managed and operated as a consistency group.

consistency of S-VOL

A state in which a reliable copy of S-VOL data from a previous update cycle is available at all times on the remote storage system. A consistent copy of S-VOL data is internally pre-determined during each update cycle and maintained in the remote data pool. When remote takeover operations are performed, this reliable copy is restored to the S-VOL, eliminating any data discrepancies. Data consistency at the remote site enables quicker restart of operations upon disaster recovery.

control unit (CU)

CPU component that implements microprocessor instructions.

count-key data (CKD)

Count-key data is a format for encoding data on hard drives, typically used in the mainframe environment. It is a physical disc format (Count, Key, Data) introduced by IBM with the Series/360 2311 disks in 1964. Count-key-data (CKD) disks format each track as a new file is written on that track (all files have at least one track). CKD disks, like SCSI and IDE, have sector (count) ID fields and data fields. CKD disks can also have a third kind of field between ID and data called a key field.

CRC

Cyclical Redundancy Checking, a scheme for checking the correctness of data that has been transmitted or stored and retrieved. A CRC consists of a fixed number of bits computed as a function of the data to be protected, and appended to the data. When the data is read or received, the function is recomputed, and the result is compared to that appended to the data.

CSV

Comma-Separated Values.

CTG

See Consistency Group.

cycle time

A user specified time interval used to execute recurring data updates for remote copying. Cycle time updates are set for each storage system and are calculated based on the number of consistency groups CTG.

cycle update

Involves periodically transferring differential data updates from the P-VOL to the S-VOL. TrueCopy Extended Distance Software remote replication processes are implemented as recurring cycle update operations executed in specific time periods (cycles).

D**Dark Fiber**

An optical fibre cable that has been physically laid, but has not been activated. Fibre optic cable is generally laid in large increments and not all the fibres within the cable are activated at the outset.

data pool

One or more disk volumes designated to temporarily store un-transferred differential data (in the local storage system or snapshots of backup data in the remote storage system). The saved snapshots are useful for accurate data restoration (of the P-VOL) and faster remote takeover processing (using the S-VOL).

data volume

A volume that stores database information. Other files, such as index files and data dictionaries, store administrative information (metadata).

DDL

Data Definition Language.

device emulation

See logical volume image (LVI).

DHCP

Dynamic Host Configuration Protocol, allows a computer to join an IP-based network without having a pre-configured IP address. DHCP is a protocol that assigns unique IP addresses to devices, then releases and renews these addresses as devices leave and re-join the network.

differential data control

The process of continuously monitoring the differences between the data on two volumes and determining when to synchronize them.

differential data copy

The process of copying the updated data from the primary volume to the secondary volume. The data is updated from the differential data control status (the pair volume is under the suspended status) to the primary volume.

Differential Management Logical Unit (DM-LU)

The volumes used to manage differential data in a storage system. In a TrueCopy Extended Distance system, there may be up to two DM logical units configured per storage system. For Copy-on-Write and ShadowImage, the DM-LU is an exclusive volume used for storing data when the array system is powered down.

differential-data

The original data blocks replaced by writes to the primary volume. In Copy-on-Write, differential data is stored in the data pool to preserve the copy made of the P-VOL to the time of the snapshot.

direct access storage device (DASD) fast write (DFW)

An attribute of record caching (while DASD Fast Write Access is a function of record caching) in which a specified record ID is placed in the cache and nonvolatile storage when a file-type macro is issued. If the cache is not available or the nonvolatile storage is not available, the record is written directly to the DASD surface.

disaster recovery

A set of procedures to recover critical application data and processing after a disaster or other failure. Disaster recovery processes include failover and fallback procedures.

disk array

An enterprise storage system containing multiple disk drives. Also referred to as "disk array device" or "disk storage system."

disk controller unit (DKC)

Consists of Cache and other components except DKU.

DLM

Data Lifecycle Management, the policies, processes, practices, services and tools used to align the business value of data with the most appropriate and cost-effective storage infrastructure from the time data is created through its final disposition. Data is aligned with business requirements through management policies and service levels associated with performance, availability, recoverability, cost, etc.

DM-LU

See Differential Management-Logical Unit.

DNS manager

The Domain Name System (manager) provides host-name resolution services to clients. It also balances requests across all nodes to ensure maximum cluster throughput and availability.

Drive operation time

The period of time from when a command is issued to the drive to then the command has completed execution. The number of tags is the maximum number of tags per second.

dual copy

The process of simultaneously updating a P-VOL and S-VOL while using a single write operation.

duplex

The transmission of data in either one or two directions. Duplex modes are full-duplex and half-duplex. Full-duplex is the simultaneous transmission of data in two direction. For example, a telephone is a full-duplex device, because both parties can talk at once. In contrast, a walkie-talkie is a half-duplex device because only one party can transmit at a time.

DWDM

Dense Wave Division Multiplexing, used to multiplex optical signals of several dozen channels.

E**EMI**

Electromagnetic interference—a disturbance caused in an electrical circuit by electromagnetic radiation emitted from an external source. The disturbance may interrupt, obstruct, or degrade the effective performance of the circuit.

encryption

The translation of data into a secret code to achieve data security. To read an encrypted file, a secret key or password is required for decryption.

entire copy

Copies all data in the primary volume to the secondary volume to make sure that both volumes are identical.

extender

A converter used to change signals when data is transmitted over long distances. For example, changing a fibre channel signal to a signal for dark fibre or an Ethernet (IP).

extent

A contiguous area of storage in a computer file system that is reserved for writing or storing a file.

F

fabric

The hardware that connects workstations and servers to storage devices in a SAN. The SAN fabric enables any-server-to-any-storage device connectivity through the use of Fibre Channel switching technology.

failover

The automatic substitution of a functionally equivalent system component for a failed one. The term failover is most often applied to intelligent controllers connected to the same storage devices and host computers. If one of the controllers fails, failover occurs, and the survivor takes over its I/O load.

fallback

Refers to the process of restarting business operations at a local site using the P-VOL. It takes place after the storage systems have been recovered.

Fault tolerance

A system with the ability to continue operating, possibly at a reduced level, rather than failing completely, when some part of the system fails.

FC

See fibre channel.

FC-AL

Fibre Channel-Arbitrated Loop—fibre channel topology in which devices are connected in a one-way loop fashion in a ring topology.

FCIP

See Fibre Channel Internet Protocol.

FCP

Fibre-Channel Protocol.

fibre channel

A gigabit-speed network technology primarily used for storage networking.

Fibre Channel Internet Protocol (FCIP)

A tunneling protocol based on the TCP/IP which connects geographically distant fibre channel SANs without affecting fibre channel and IP protocols.

FIFO

See First In First Out.

firmware

Software embedded into a storage device. It may also be referred to as Microcode.

First In First Out

One way Tuning options in SNM2 can be configured to organize and manipulate data relative to time and prioritization. Data that arrives first is handled by the subsystem first; data that arrives after is queued to be processed after the first batch of data are handled.

fixed block architecture

A model of disks in which storage space is organized as linear, dense address spaces of blocks of a fixed size. Abbreviated FBA, fixed block architecture is the disk model on which SCSI is predicated.

fixed-content data

An exact digital reproduction of a data file as it existed before the file was archived. Fixed-content data cannot be modified or deleted before its retention period expires.

full duplex

The concurrent transmission and the reception of data on a single link.

G**gateway**

Functions as a node that enables user and application access into other networks.

Gbps

Gigabit per second.

Gigabit Ethernet (GbE)

A term describing various technologies for transmitting Ethernet frames at a rate of one gigabit per second, as defined by the IEEE 802.3-2005 standard.

granularity of differential data

Refers to the size or amount of data transferred to the S-VOL during an update cycle. Since only the differential data in the P-VOL is transferred to the S-VOL, the size of data sent to S-VOL is often the same as that of data written to the P-VOL. The amount of differential data that can be managed per write command is limited by the difference between the number of incoming host write operations (inflow) and outgoing data transfers (outflow).

GUI

Graphical user interface.

H**HBA**

See Host Bus Adapter.

HCA cluster

An implementation of Hitachi Content Archiver. An HCA cluster is both a repository that stores terabytes of data and a gateway that enables access to that data.

HDD

Hard disk drive.

High Availability (HA) software

An application designed for use during a primary host or disk failure. The software switches the failed host to a standby host (fail-over). High Availability software must be installed on the primary and secondary hosts.

Host Bus Adapter

An I/O adapter that connects a host I/O bus to the memory system of a computer.

I**I/O**

Input/output.

ICKDSF

Installs, initializes and maintains [DASD](#), either under an operating system, or standalone.

IDE

Integrated drive electronics; see also ATA

Internet Fibre Channel Protocol (iFCP)

A TCP/IP based protocol for connection of fibre channel data storage systems using the IP infrastructure together or instead of fibre channel switching and routing elements. Allows users to maintain the Fibre Channel architecture while gaining the benefits of IP networks.

initial copy

An initial copy operation involves copying all data in the primary volume to the secondary volume prior to any update processing. Initial copy is performed when a volume pair is created.

initiator

A system component that originates an I/O command over an I/O bus or network, such as an I/O adapters or network interface cards.

initiator ports

A port-type used for main control unit port of Fibre Remote Copy function.

internal predetermined data

Also, internally determined data. See consistent internal data.

IOPS

I/O per second.

IOS

Internetwork Operating System.

IP-SAN

Block-level Storage Area Networks over TCP/IP using the iSCSI protocol.

iSCSI

Internet-Small Computer Systems Interface, a TCP/IP protocol for carrying SCSI commands over IP networks.

iSNS

Internet Storage Name Service, a protocol through which hosts can automatically discover and establish sessions with both fibre channel and IP-based storage resources in an IP storage network.

J**Java application**

A program written in the Java™ programming language that can be included in an HTML page. When you use a Java technology-enabled browser to view a page that contains an applet, the applet's code is transferred to your system and executed by the browser's Java Virtual Machine (JVM).

journal volume

A volume that records and stores a log of all events that take place in the volume. In the event of a system crash, the journal volume logs are used to restore lost data and maintain data integrity.

JRE

Java Runtime Environment.

L**LAN**

Local Area Network, a computer network that spans a relatively small area, such as a single building or group of buildings.

link aggregation

A computer networking term which describes using multiple Ethernet network cables/ports in parallel to increase the link speed beyond the limits of any one single cable or port, and to increase the redundancy for higher availability.

load

In UNIX computing, the system load is a measure of the amount of work that a computer system is doing.

logical

Describes a user's view of the way data or systems are organized. The opposite of logical is physical, which refers to the real organization of a system. A logical description of a file is that it is a quantity of data collected together in one place. The file appears this way to users. Physically, the elements of the file could live in segments across a disk.

logical unit

See logical unit number.

logical unit number (LUN)

An address for an individual disk drive, and by extension, the disk device itself. Used in the SCSI protocol as a way to differentiate individual disk drives within a common SCSI target device, like a disk array. LUNs are normally not entire disk drives but virtual partitions (or volumes) of a RAID set.

logical volume

An area on a disk consisting of device files that are logically integrated using a volume manager.

logical volume image (LVI)

A feature used to create virtual logical units that are up to 36 times larger than the standard OPEN-x logical units.

LU

Logical unit.

LUN

See logical unit number.

LUN Manager

This storage feature is operated through Storage Navigator Modular 2 software and manages access paths among host and logical units for each port in your array.

LVM

Logical volume manager. In general, logical volume management provides a higher-level view of the disk storage on a computer system than the traditional view of disks and partitions. This gives the system administrator much more flexibility in allocating storage to applications and users.

M**mainframe**

A large and expensive computer capable of simultaneously supporting thousands of users. In this document the term mainframe is used for IBM computers (zSeries[®] and S/390[®]-based systems). This term also marks a distinction between Unix or Windows server computers and the larger more, powerful mainframe. A mainframe is also commonly referred to as the *host*, even though any computer host having a unique IP address can equally be referred to as a *host*.

MDB

Master Directory Block.

metadata

In sophisticated data systems, the metadata -- the contextual information surrounding the data -- will also be very sophisticated, capable of answering many questions that help understand the data.

MIB

Message Information Block

microcode

The lowest-level instructions directly controlling a microprocessor. Microcode is generally hardwired and cannot be modified. It is also referred to as firmware embedded in a storage subsystem.

Microsoft Cluster Server

Microsoft Cluster Server is a clustering technology that supports clustering of two NT servers to provide a single fault-tolerant server.

Middleware

Software that connects two otherwise separate applications. For example, a middleware product can be used to link a database system to a Web server. Using forms, users request data from the database; then, based on the user's requests and profile, the Web server returns dynamic Web pages to the user.

mount

To mount a device or a system means to make a storage device available to a host or platform.

mount point

The location in your system where you mount your file systems or devices. For a volume that is attached to an empty folder on an NTFS file system volume, the empty folder is a mount point. In some systems a mount point is simply a directory.

multiple allegiance support

With multiple allegiance support the storage unit can accept concurrent I/O requests for a volume from multiple channel paths. Thus, the storage unit can process requests from separate FICON hosts in parallel, improving throughput and performance.

multiple virtual storage

MVS is an operating system that runs on IBM or compatible mainframe computers. The host component works on MVS/ESA (Enterprise Systems Architecture) and MVS/XA (Extended Architecture).

Multiplex command

Multiplexing refers to a process where multiple analog message signals or digital data streams are combined into one signal. The aim is to share an expensive resource.

MU

Mirrored unit.

N

NAS

Network-Attached Storage, refers to storage elements that connect to a network and provide file access services to computer systems. Also, a class of systems that provide file services to host computers.

NEC

National Electrical Co

Netboot device

A technology from Apple that enables New World ROM Macs to boot from a network.

Network switch (network attached)

A computer networking device that connects network segments.

NIC

Network Interface Card, an expansion board in a computer that allows the computer to connect to a network

NIS

Network Information Service, Sun Microsystems' client-server directory service protocol for distributing system configuration data such as user and host names between computers on a computer network.

node

In networks, a node is a processing location. A node can be a computer or other device, such as a printer. Every node has a unique network address.

NSC

Network Storage Controller.

NTP

Network Time Protocol, a protocol for synchronizing the clocks of computer systems over packet-switched, variable-latency data networks. NTP uses UDP port 123 as its transport layer. It is designed particularly to resist the effects of variable latency (jitter) .

O

OSI

Open Systems Interconnection, a networking industry effort to provide common network standards for multi-vendor interoperability.

P

pair

Refers to two logical volumes that are associated with each other for data management purposes (e.g., replication, migration). A pair is usually composed of a primary or source volume and a secondary or target volume as defined by the user.

pair splitting

The operation that splits a pair. When a pair is "Paired", all data written to the primary volume is also copied to the secondary volume. When the pair is "Split", the primary volume continues being updated, but data in the secondary volume remains as it was at the time of the split, until the pair is re-synchronized.

pair status

Internal status assigned to a volume pair before or after pair operations. Pair status transitions occur when pair operations are performed or as a result of failures. Pair statuses are used to monitor copy operations and detect system failures.

paired volume

Two volumes that are paired in a disk array.

panel

Equivalent to a *window*.

parity

The technique of checking whether data has been lost or corrupted when it's transferred from one place to another, such as between storage units or between computers. It is an error detection scheme that uses an extra checking bit, called the parity bit, to allow the receiver to verify that the data is error free. Parity data in a RAID array is data stored on member disks that can be used for regenerating any user data that becomes inaccessible.

parity groups

RAID groups can contain single or multiple parity groups where the parity group acts as a partition of that container.

path blockade watch

Specifies the time for monitoring blockade in the Fibre Channel paths on the main control unit side. The path blockade watch value must be from 0 to 45 seconds. This setting is available for the Fibre Channel interface only.

pattern file

A table that contains the access attributes of all logical volumes. Pattern files enable administrators to change the access attributes of all logical volumes quickly and easily.

payload

In communication, telecommunications and information science, the payload or mission bit stream is the data, such as a data field, block, or stream, being processed or transported — the part that represents user information and user overhead information. It may include user-requested additional information, such as network management and accounting information. Note that the payload does not include system overhead information for the processing or transportation system.

PCI

Power Control Interface.

peer-to-peer remote copy (PPRC)

A hardware-based solution for mirroring logical volumes from a primary site (the application site) onto the volumes of a secondary site (the recovery site).

point-in-time logical copy

A logical copy or snapshot of a volume at a point in time. This enables a backup or mirroring application to run concurrently with the system.

point-to-point

A configuration that allows two ports to connect serially.

pool volume

Used to store backup versions of files, archive copies of files, and files migrated from other storage.

POSIX

Portable Operating System Interface for UNIX, a set of standards that define an application programming interface (API) for software designed to run under heterogeneous operating systems.

primary or local site

The host computer where the primary volume of a remote copy pair (primary and secondary volume) resides. The term "primary site" is also used for host failover operations. In that case, the primary site is the host computer where the production applications are running, and the secondary site is where the backup applications run when the applications on the primary site fail, or where the primary site itself fails.

primary volume (P-VOL)

The storage volume in a volume pair. It is used as the source of a copy operation. In copy operations a copy source volume is called the P-VOL while the copy destination volume is called "S-VOL" (secondary volume).

P-VOL

See primary volume.

Q**QOS**

Quality of Service, a networking term that specifies a guaranteed throughput level.

queue depth

When a host queues successive commands to the array before execution of a previous command can complete, the number of times successive commands are issued is called queue depth. When two or more hosts are connected to a port of an array, the number of queue commands for the port is increased because the host issues commands to each array separately.

quota values

Set for write access enabled users and provide data storage limits for that user/volume. Quota values are applied to a snapshot and set for the target file system when the snapshot is taken.

R**RAID**

Redundant Array of Independent Disks, a disk array in which part of the physical storage capacity is used to store redundant information about user data stored on the remainder of the storage capacity. The redundant information enables regeneration of user data in the event that one of the array's member disks or the access path to it fails.

RAID 6

An extension of the RAID 5 array. Allows for two simultaneous drive failures without downtime or data loss.

Recovery Point Objective (RPO)

After a recovery operation, the RPO is the maximum desired time period, prior to a disaster, in which changes to data may be lost. This measure determines up to what point in time data should be recovered. Data changes preceding the disaster are preserved by recovery.

Recovery Time Objective (RTO)

The maximum desired time period allowed to bring one or more applications, and associated data back to a correct operational state. It defines the time frame within which specific business operations or data must be restored to avoid any business disruption.

Redundant paths

The duplication of critical paths with the intention of increasing reliability.

Remote Control Unit target port

A port-type used for the remote control unit target port of Fibre Remote Copy function. This port allows login of host computers and main control units.

remote or target site

Maintains mirrored data from the primary site.

remote path

A route connecting identical ports on the local storage system and the remote storage system. Two remote paths must be set up for each storage system (one path for each of the two controllers built in the storage system).

remote volume stem

In TrueCopy operations, the remote volume (R-VOL) is a volume located in a different subsystem from the primary host subsystem.

repeater

A network device used to regenerate or replicate a signal. A repeater relays messages between sub-networks that use different protocols or cable types. A repeater cannot do the intelligent routing performed by bridges and routers.

resynchronization

Refers to the data copy operations performed between two volumes in a pair to bring the volumes back into synchronization. The volumes in a pair are synchronized when the data on the primary and secondary volumes is identical.

RPO

See Recovery Point Objective.

RTC

Real-time clock.

RTO

See Recovery Time Objective.

S**SAN**

Storage Area Network, a network of shared storage devices that contain disks for storing data.

SAS

Serial Attached SCSI, an evolution of parallel SCSI into a point-to-point serial peripheral interface in which controllers are linked directly to disk drives. SAS delivers improved performance over traditional SCSI because SAS enables up to 128 devices of different sizes and types to be connected simultaneously.

SATA

Serial ATA is a computer bus technology primarily designed for the transfer of data to and from hard disks and optical drives. SATA is the evolution of the legacy Advanced Technology Attachment (ATA) interface from a parallel bus to serial connection architecture.

SCSI

Small Computer System Interface, a parallel interface standard that provides faster data transmission rates than standard serial and parallel ports.

secondary volume (S-VOL)

A replica of the primary volume (P-VOL) at the time of a backup and is kept on a standby storage system. Recurring differential data updates are performed to keep the data in the S-VOL consistent with data in the P-VOL.

sequential data striping

Writes data to multiple disk drives in a pre-planned sequence.

server set identifier (SSID)

A code attached to all packets on a wireless network to identify each packet as part of that network. The code is a [case sensitive](#) text string that consists of a maximum of 32 alphanumeric [characters](#). All wireless devices attempting to communicate with each other must share the same SSID.

service

A set of functions within the Open Systems Interconnection (OSI) model. It enables delivery from one OSI layer to the layer above. For example, the TCP layer provides a reliable byte-stream service to the application layer above it.

SES

SCSI Enclosure Service.

session

A series of communications or exchanges of data between two end points that occurs during the span of a single connection. The session begins when the connection is established at both ends, and terminates when the connection is ended. For some applications each session is related to a particular port. In this document a session is the exchange of data between groups of primary and secondary volumes

sidefile

Holds data that changes or updates while a backup or other duplication is performed. The data may later be integrated back into the storage device.

SLA

Service Level Agreement.

SMB

Server Message Block, network protocol that allows shared access to files, printers, and serial points. SMB also allows clients to access files on a remote computer as if they were part of a local file system. See also Common Internet File System (CIFS) above.

SMPL

Simplex.

SMTP

Simple Mail Transfer Protocol, a protocol used to receive and store email data directly from email servers.

snapshot

A term used to denote a copy of the data and data-file organization on a node in a disk file system. A snapshot is a replica of the data as it existed at a particular point in time.

SNM2

See Storage Navigator Modular 2.

SNMP

Simple Network Management Protocol, a protocol used to facilitate monitoring and management of clusters through an external interface. SNMP sends notifications to IP addresses whenever certain types of events occur.

software initiator

A software application initiator communicates with a target device. A software initiator does not require specialized hardware because all processing is done in software, using standard network adapters.

SONET

Synchronous Optical Network.

source copy

The original location from which data is taken or moved. The source can also indicate the node on a network from which data is sent to its destination.

SSL

Secure Sockets Layer, a key-based Internet protocol for transmitting documents through an encrypted link.

SSL certificate

A file containing the cryptographic keys and signatures used with an SSL protocol to verify the authenticity of web sites to protect data sent to or from that site.

status transition

The act of changing the pair status of the pair volume.

Storage Navigator Modular 2

A multi-featured scalable storage management application that is used to configure and manage the storage functions of Hitachi arrays. Also referred to as "Navigator 2".

Subnet

In computer networks, a subnet or subnetwork is a range of logical addresses within the address space that is assigned to an organization. Subnetting is a hierarchical partitioning of the network address space of an organization (and of the network nodes of an autonomous system) into several subnets. Routers constitute borders between subnets. Communication to and from a subnet is mediated by one specific port of one specific router, at least momentarily.

suspended status

Occurs when the update operation is suspended while maintaining the pair status. During suspended status, the differential data control for the updated data is performed in the primary volume.

S-VOL

See secondary volume.

S-VOL determination

Independent of update operations, S-VOL determination replicates the S-VOL on the remote storage system. This process occurs at the end of each update cycle and a pre-determined copy of S-VOL data, consistent with P-VOL data, is maintained on the remote site at all times.

Switch (such as a hub)

A network infrastructure component to which multiple nodes attach. Unlike hubs, switches typically have internal bandwidth that is a multiple of link bandwidth, and the ability to rapidly switch node connections from one to another. A typical switch can accommodate several simultaneous full link bandwidth transmissions between different pairs of nodes.

Sysplex

Denotes system complex. This is a processor complex formed by connecting a number of processors together into a single unit through channel-to-channel adapters or ESCON/FICON fiber optic links. The processors are synchronized using a Sysplex Timer and are managed as a single system image (SSI1). The Sysplex Timer is an invaluable component when systems on multiple CPCs share access to the same data.

system reduction

Refers to maintenance tasks that improve system performance in a replication environment. These tasks may include pair deletion, deletion of command devices, and data pools.

T

takeover processing

Involves transferring critical application processing to the S-VOL on the remote standby storage system. The remote S-VOL is immediately enabled to process subsequent host I/O operations.

target

Devices that receive iSCSI requests that originate from an iSCSI initiator.

target copy

A file, device, or any type of location to which data is moved or copied.

target port

A port-type which differs from an "Initiator Port" or "Remote Control Unit Target Port". The target is used without configuration of Fibre Remote Copy. It allows LOGIN of host computers, but does not allow LOGIN of MCUs

target site

See remote or target site.

TCP (Transmission Control Protocol)

A transportation protocol that is one of the core protocols of the IP suite. The Internet protocol exchanges groups of information -- packets, which are short sequences of bytes consisting of a header and a body. In cases of congestion, the IP can discard packets, or, for efficiency reasons, route two consecutive packets differently over the internet to the destination, which can result in the packets arriving in the wrong order. TCP software provides a simpler interface to applications by hiding most of the underlying packet structures, rearranging out-of-order packets, minimizing network congestion, and re-transmitting discarded packets.

TID

Target ID.

tier architecture

Describes a layered structure of hardware development. Each layer in the structure is more complete and is supported more than the layer below it. Tier 1 is fully supported computing expected to be production quality. Tier 2 platforms are not supported by the security officer and release engineering teams. Tier 2 systems are targeted at Tier 1 support, but are still under development. Tier 3 platforms are architectures for which hardware is not or will not be available or which are considered legacy systems unlikely to see broad future use. Tier 4 systems are not supported in any way. Tier 1: Static content, Tier 2: Application logic, Tier 3: Database.

TOE

A dedicated chip or adapter that handles much of the TCP/IP processing directly in hardware. TCP/IP transmission is inherently a CPU-intensive operation. Therefore, using dedicated hardware that can operate in parallel with the main processor allows for superior system performance. Although all iSCSI HBAs have a TOE, a generic TOE only implements TCP/IP, while an iSCSI HBA implements the iSCSI protocol in addition to TCP/IP.

track

A ring on a disk where data can be written. For hard disks, tracks aggregate into platters. A single track location that cuts through all platters is termed a cylinder. Each track can be subdivided into a number of sectors allowing the operating system and disk drive to find stored information using its track and sector numbers.

Transparent

A failover from one component of a system to another that is transparent to the external operating environment. Often used to refer to paired disk controllers, one of which exports the other's virtual disks at the same host bus addresses after a failure.

trap

A program interrupt usually caused by some exceptional situation in a user program. In most cases, the OS performs an appropriate action and then returns control to the program.

truck size

Represents a fixed sector size for each volume type.

U**UDP**

User Diagram Protocol.

User Datagram Protocol (UDP)

One of the core protocols of the Internet protocol suite. Using UDP, programs on networked computers can send short messages sometimes known as datagrams (using Datagram Sockets) to one another. UDP does not guarantee reliability or ordering in the way that TCP does. Datagrams may arrive out of order, appear duplicated, or go missing without notice. Avoiding the overhead of checking whether every packet actually arrived makes UDP faster and more efficient, at least for applications that do not need guaranteed delivery. Time-sensitive applications often use UDP because dropped packets are preferable to delayed packets. UDP's stateless nature is also useful for servers that answer small queries from huge numbers of clients. Unlike TCP, UDP is compatible with packet broadcast (sending to all on local network) and multicasting (send to all subscribers).

V

VA

Validation Authority.

Virtual Local Area Network

A logical network that behaves as if it is physically separate from other physical and virtual LANs supported by the same switches and/or routers.

virtual LVI/ LUN (VLL)

An option that enables the configuration of custom-size logical device images and logical units, which are smaller than standard size devices. Virtual LVI/LUN is enables the configuration of custom-size logical device images and logical units, which are smaller than standard size devices.

virtual volume (V-VOL)

In Copy-on-Write, a secondary volume in which a view of the primary volume (P-VOL) is maintained as it existed at the time of the last snapshot. The V-VOL contains no data but is composed of pointers to data in the P-VOL and the data pool. The V-VOL appears as a full volume copy to any secondary host.

VLAN

See Virtual Local Area Network.

volume

A disk array object that most closely resembles a physical disk from the operating environment's viewpoint. The basic unit of storage as seen from the host.

volume copy

Copies all data from the P-VOL to the S-VOL.

volume pair

Formed by pairing two logical data volumes. It typically consists of one primary volume (P-VOL) on the local storage system and one secondary volume (S-VOL) on the remote storage systems.

volume signature

An integer that is an element in the master directory block (MDB) (volume information block (VIB)). For example, for HFS volumes, this field (drSigWord) contains the number \$4244.

V-VOL

See virtual volume.

V-VOLTL

Virtual Volume Tape Library.

W**WAN**

Wide-Area Network.

WDM

Wavelength-division multiplexing, a technology which multiplexes multiple optical carrier signals on a single optical fibre by using different wavelengths (colors) of laser light to carry different signals. This allows for a multiplication in capacity, in addition to making it possible to perform bidirectional communications over one strand of fibre.

wide area network

A communications network that is geographically dispersed and that includes telecommunications links.

WMS

Workgroup Modular Storage.

World Wide Name (WWN)

A unique identifier for an open systems host. It consists of a 64-bit physical address (the IEEE 48-bit format with a 12-bit extension and a 4-bit prefix). The WWN is essential for defining the SAnTinel™ parameters because it determines whether the open systems host is to be allowed or denied access to a specified logical unit or a group of logical units.

WORM

Write once, read many, a data storage technique in which files are protected from being modified, overwritten, or deleted.

write order guarantee

Ensures that data is updated in an S-VOL, in the same order that it is updated in the P-VOL, particularly when there are multiple write operations in one update cycle. This feature is critical to maintain data consistency in the remote S-VOL and is implemented by inserting sequence numbers in each update record. Update records are then sorted in the cache within the remote system, to assure write sequencing.

write workload

The amount of data written to a volume over a specified period of time.



Index

- array unit system components, 5-2
- boot options information, 4-32
- CHAP, 1
- CHAP User information, 4-37, 5-110
- CLI, 1
- command device LU size, 5-39
- command execution activity, 5-134
- constituent parts status, 4-15, 5-92
- create RAID group, 5-13
- DAMP, 1
- data in cache, 5-136
- DDL, 1
- DHCP, 1
- Differential Management LU, 5-36
- dual active mode, 5-20
- fibre setting information, 5-101
- firmwares download, 5-114
- Free Capacity field, 5-20
- GUI, 1
- HACMP, 1
- HDLM, 1
- HDU, 1
- HDU number, 5-16
- host group information, 5-99, 5-102
- host side, 1-2
- inflow limit, 5-136
- interval time, 5-115
- iSCSI port information, 5-107
- iSCSI port parameters, 5-74
- iSCSI setting information, 4-29
- JRE, 1
- key code, 5-45
- LAN, 1
- LAN cards, 1-13
- LAN configuration, 5-10
- LIP, 1
- local host, 1-13
- logical unit icon, 5-7
- logical unit information, 5-24
- logical units
 - required qty, 5-123
- login information, 3-4
- loop back address, 3-3
- LU, 1
- LUN, 1
- mapping guard, 5-51
- MB, 1
- message
 - DMES05EA03, 5-118
- minimum logical unit size, 5-36
- NAS System LU and NAS User LU information, 5-105
- NNC option, 5-122
- NTP, 1
- OS, 1
- parity restoration, 5-28
- patrol lamp icon, 5-11
- PC, 1
- ping command, 1-5
- ping parameters, 4-44, 5-76
- port information, 4-26
- powering on display, 5-133
- prefetch parameters, 5-151
- PS, 1
- PSUE, 1
- PSUS, 1
- PV, 1
- P-VOL, 1
- RAID, 1
- RAID definition information, 5-12
- RAID group number, 5-5
- reset/LIP, 1-3
- RTC, 1
- SCSI, 1
- Set host group 0, 5-48
- set LAN configuration, 5-85
- SMPL, 1
- SNMP, 2
- spare drive, 5-33
- state
 - locked and unlocked, 4-18, 5-94
- suspension status, 1-2
- S-VOL, 2
- system LU, 5-125, 5-127

TCP/IP communication, 1-2
TCP/IP port number, 3-1
TID, 2
unit screens, 1-2
update the component display, 5-9

user data
 is lost, 4-22, 5-97
user LU list, 5-128
VCS, 2
warning state, 5-120

Hitachi Data Systems

Corporate Headquarters

750 Central Expressway
Santa Clara, California 95050-2627
U.S.A.
Phone: 1 408 970 1000
www.hds.com
info@hds.com

Asia Pacific and Americas

750 Central Expressway
Santa Clara, California 95050-2627
U.S.A.
Phone: 1 408 970 1000
info@hds.com

Europe Headquarters

Sefton Park
Stoke Poges
Buckinghamshire SL2 4HD
United Kingdom
Phone: + 44 (0)1753 618000
info.eu@hds.com



MK-97DF8039-06